

P	LTR	DESCRIPTION	DATE	DWN	APVD
	A	RELEASED	22APR22	X.L	E.J
	A1	ECN-22-186413	23NOV22	X.F	E.J
	A2	ECN-23-204770	20JAN23	X.F	E.J

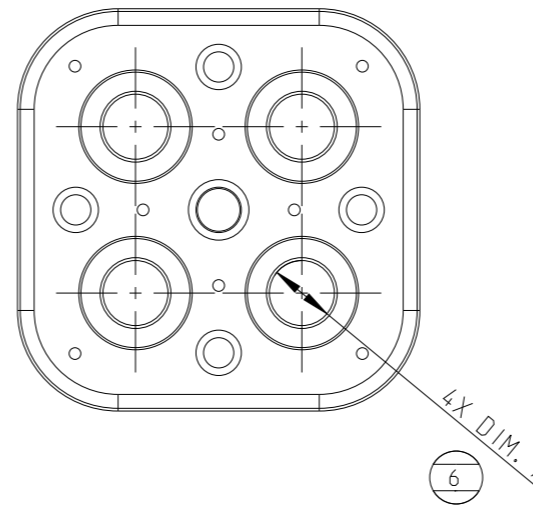
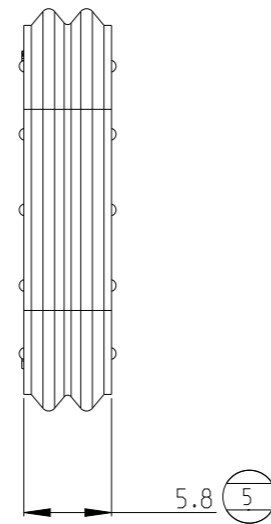
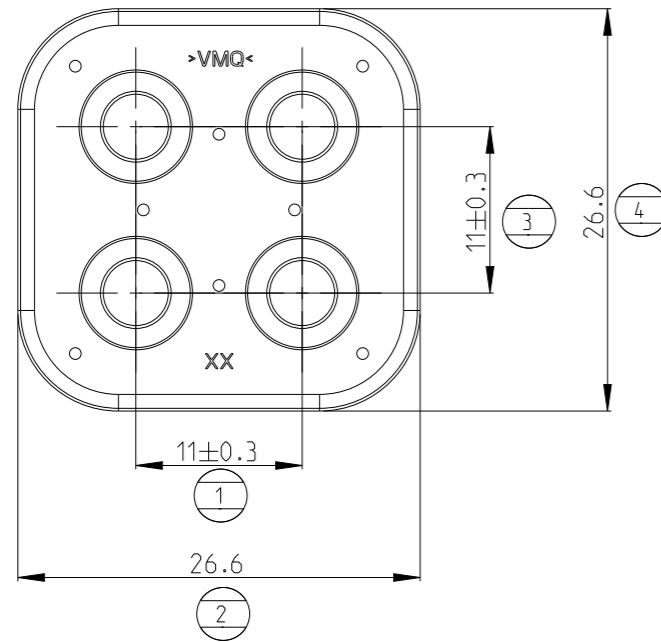
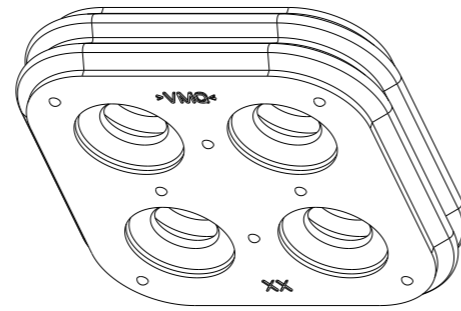
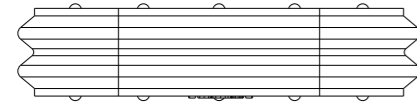

- 1 MATERIAL: SILICONE, SELF-OILING, HARDNESS 30±5;
- 2. MATING PART:
X-2404653-X PLUG ASSY
- 3 REFER TO DRAWING C-2415636

A2	COLOR	MATERIAL	WIRE O.D.	DIM. A	DESCRIPTION	REV.	PART NO.
	ORANGE	1	4.5-5.1	3.3	HVA630 4P REC CABLE SEAL	A	2404519-6
	GREY	1	3.9-4.3	2.5	HVA630 4P REC CABLE SEAL	-	2415636-1 3
	BROWN	1	4.2-4.7	2.9	HVA630 4P REC CABLE SEAL	A	2404519-4
	GREEN	1	5.3-5.8	4.0	HVA630 4P REC CABLE SEAL	A	2404519-3
	VIOLET	1	6.0-6.5	4.8	HVA630 4P REC CABLE SEAL	A	2404519-2
	BLUE	1	5.5-6.1	4.3	HVA630 4P REC CABLE SEAL	A	2404519-1

THIS DRAWING IS A CONTROLLED DOCUMENT.

DIMENSIONS: mm	TOLERANCES UNLESS OTHERWISE SPECIFIED: 0 PLC ± 1 PLC ±0.3 2 PLC ± 3 PLC ± 4 PLC ± ANGLES ±	DWN X.LI 20JAN2022	
		CHK R.CHEN 22APR2022	
		APVD E.JIANG 22APR2022	
		PRODUCT SPEC 108-160496	
MATERIAL	FINISH	APPLICATION SPEC 114-160249	NAME HVA630 4P CABLE SEAL
		WEIGHT -	SIZE A3
		CUSTOMER DRAWING	CAGE CODE 00779
			DRAWING NO C-2404519
			RESTRICTED TO -
			SCALE 2:1
			SHEET 1 OF 1
			REV A2