

1) Sensing surface, 2) LED (Tag present), 3) LED (Power), 4) LED (Status), 5) LED (RF active), 6) Tightening torque, 7) Button (Config)



Basic features

Antenna type	Patch
Approval/Conformity	FCC Part 15 IC (Radio) cULus WEEE IFT
Principle of operation	Read/write head
Radio license	USA Canada Mexico
Standards	EPCglobal™ Class 1, Gen 2 ISO 18000-6C

Display/Operation

Function indicator	Status, LED red RF active, LED blue Power, LED green Tag Present, LED yellow
--------------------	---

Electrical connection

Connection	M12x1-Male, 4-pin, A-coded
------------	----------------------------

Electrical data

Current consumption max. at 24 V DC	200 mA
Front-to-back ratio	typ.10 dB
Multi-Tag capable	yes
Nominal voltage	24 VDC
Operating voltage Ub	24 V DC LPS Class 2
Output power adjustable	7 dBm...26 dBm (5 mW...400 mW)
Permissible radiated power	≤ 0.5 W EIRP
Polarization	circular
Residual ripple max.	10 %
Working frequency	902...928 MHz

Environmental conditions

Ambient temperature	-20...55 °C
Continuous shock load	yes
EN 60068-2-27, Shock	yes
EN 60068-2-32 Free fall	yes
EN 60068-2-6, Vibration	yes
IP rating	IP54
Storage temperature	-25...70 °C

Functional safety

MTTF (40 °C)	110 a
--------------	-------

Interface

Interface	RS485
-----------	-------

UHF (860...930 MHz)
BIS VU-320-C1-S4
Order Code: BIS015Y

BALLUFF

Material

Housing material	PC, coated ABS, Zinc, Die casting, (Connector)
Housing material, surface protection	coated

Mechanical data

Application weight	850.00 g
Dimension	130 x 50.5 x 130 mm

Range/Distance

Axial ratio	typ. 1 dB
-------------	-----------

Remarks

For use only in USA, Canada and Mexico.

When installing, the technical standards and regulations of the corresponding countries must be observed.

Values are under rated conditions unless otherwise specified.

For more information about MTTF and B10d see MTTF / B10d Certificate

Indication of the MTTF- / B10d value does not represent a binding composition and/or life expectancy assurance; these are simply experiential values with no warranty implications. These declared values also do not extend the expiration period for defect claims or affect it in any way.

Connector Drawings

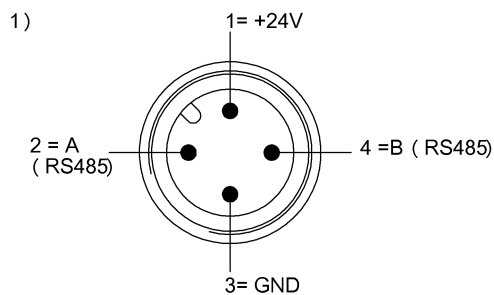

1) View towards connector

Technical Drawings

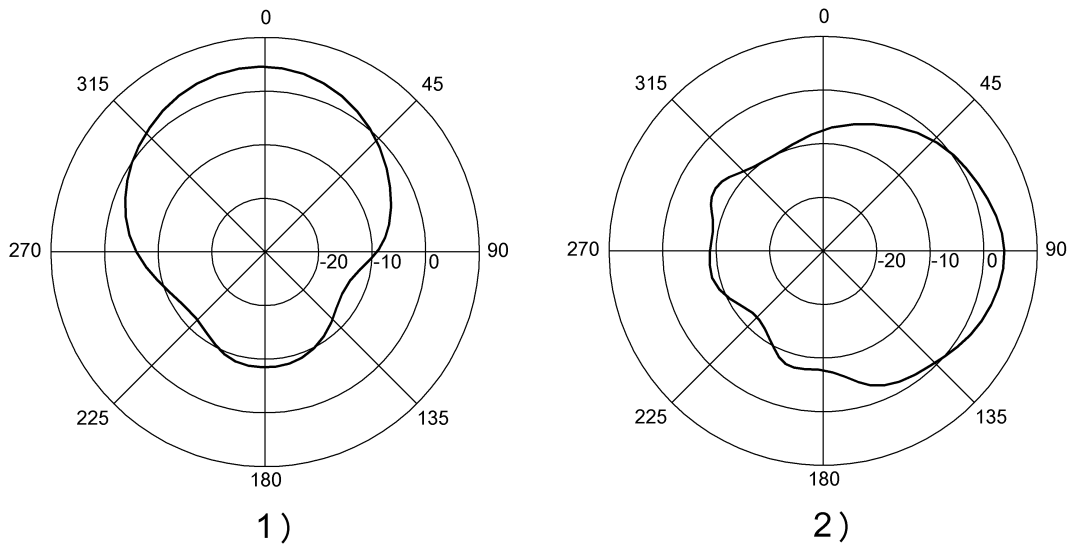

- 1) Radiation diagram horizontal
- 2) Radiation diagram vertical