

REVISIONS					
P	LTR	DESCRIPTION	DATE	DWN	APVD
A		INITIAL RELEASE	02DEC2024	GC	JM

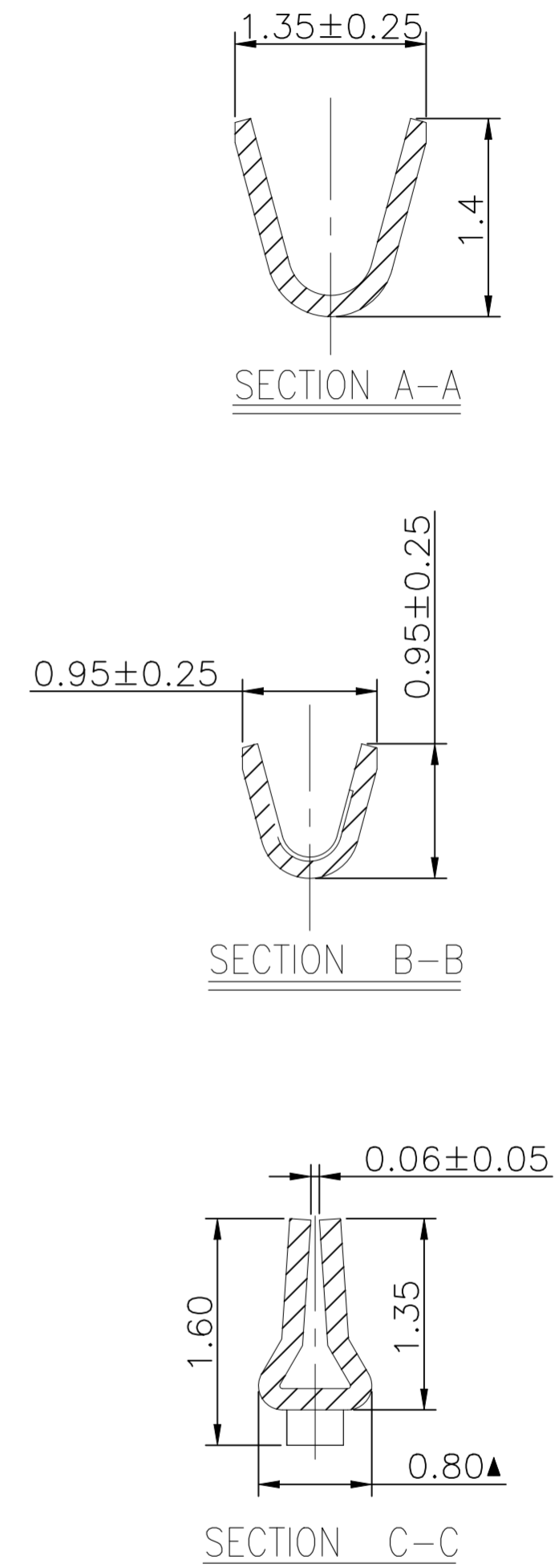
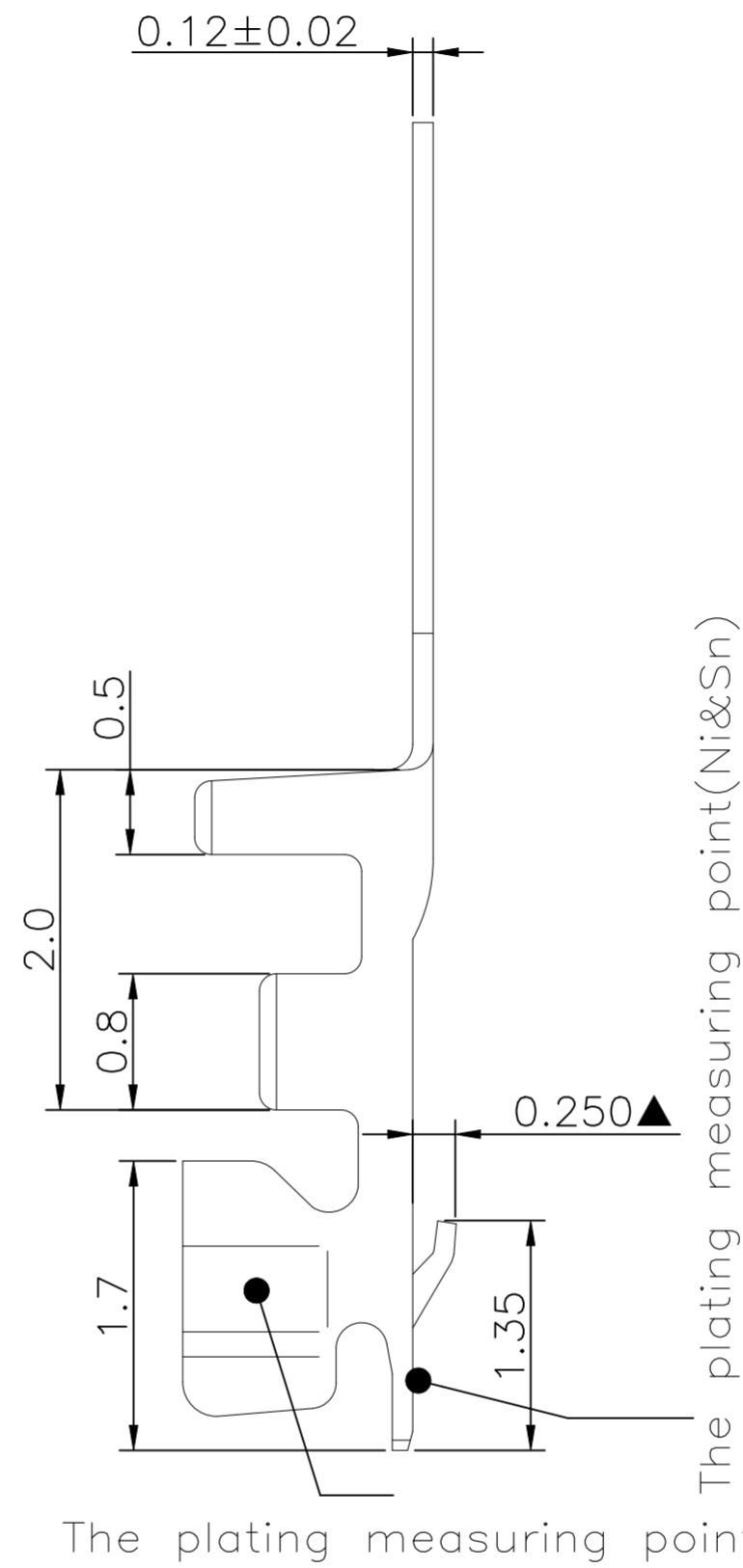
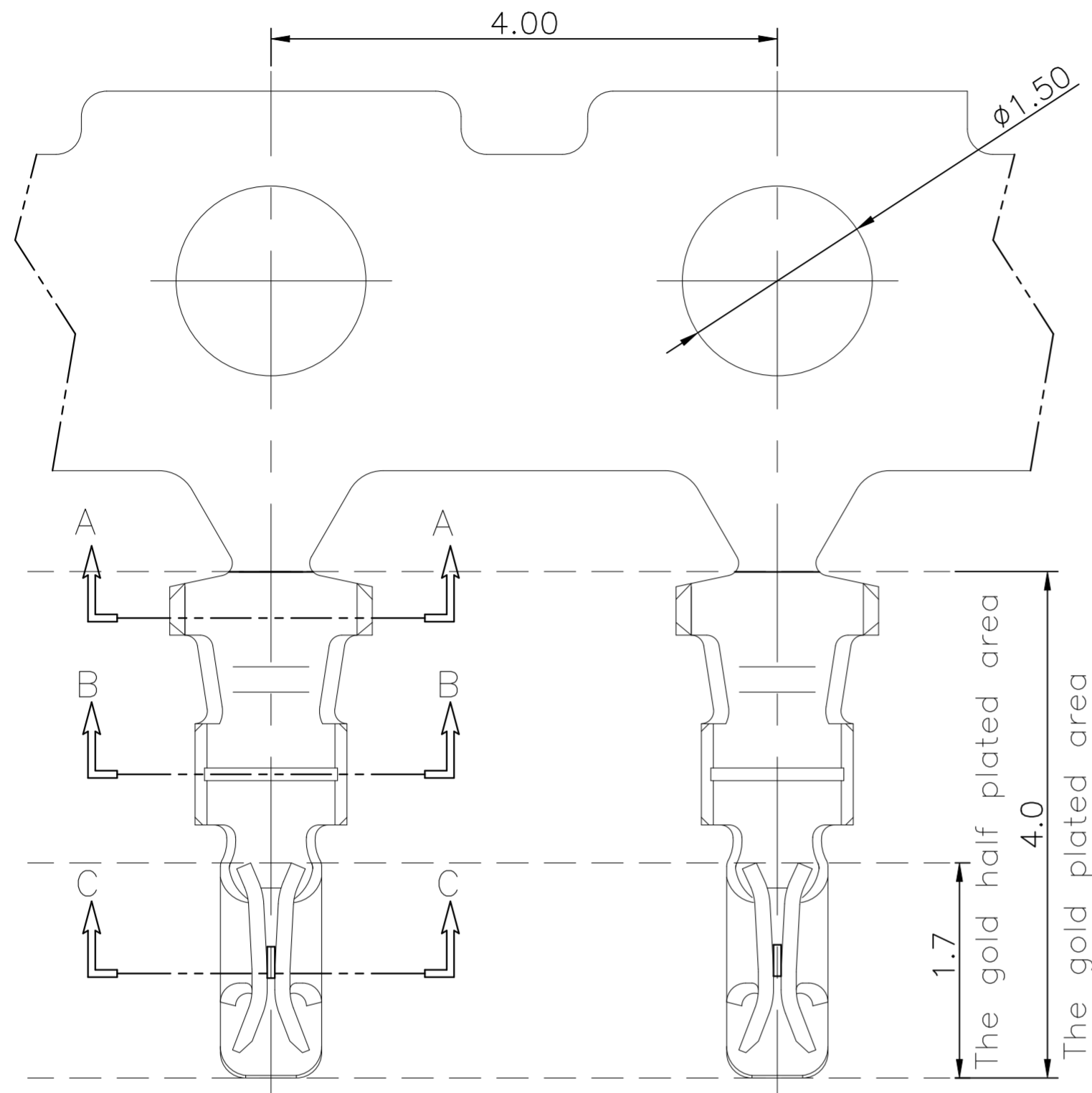

The product using material and processing must conform to the "WI-PZ-142" HSF technical standard control requirements

Specification & Ordering Information:

Options	Part No	Wire Range	Insulation O.D.	Material	Finish	Qty/reel
1	2484144-1	AWG #28~#32	0.80mm(max)	Phosphor Bronze	Ni50u"Min,Gold Flash	2,0000 PCS
2	2484144-2	AWG #28~#32	0.80mm(max)	Phosphor Bronze	Ni50u"Min,Sn80u"Min	2,0000 PCS
3	2484144-3	AWG #28~#32	0.80mm(max)	Phosphor Bronze	Ni50u"Min,Gold Plated 30u"Min.	2,0000 PCS

THIS DRAWING IS A CONTROLLED DOCUMENT.		DWN GOWTHAM 10APR2024	TE Connectivity	
		CHK GOWTHAM 16MAY2022		
		APVD SATHISH P S 16MAY2024	NAME 1mm WTB CONNECTOR	
DIMENSIONS: INCHES		TOLERANCES UNLESS OTHERWISE SPECIFIED:	PRODUCT SPEC 108-161430	
		0 PLC ± -	APPLICATION SPEC 114-161064	
		1 PLC ± 0.02	SIZE A2	
MATERIAL		2 PLC ± 0.10	CAGE CODE 00779	DRAWING NO C-2484144
		3 PLC ± 0.05	RESTRICTED TO	
		4 PLC ± 0.05	SCALE 1:1	
		ANGLES ± 2'	SHEET 1 of 2	
		FINISH	REV A	
			CUSTOMER DRAWING	

REVISIONS					
P	LTR	DESCRIPTION	DATE	DWN	APVD
-	-	SEE SHEET 1	-	-	-

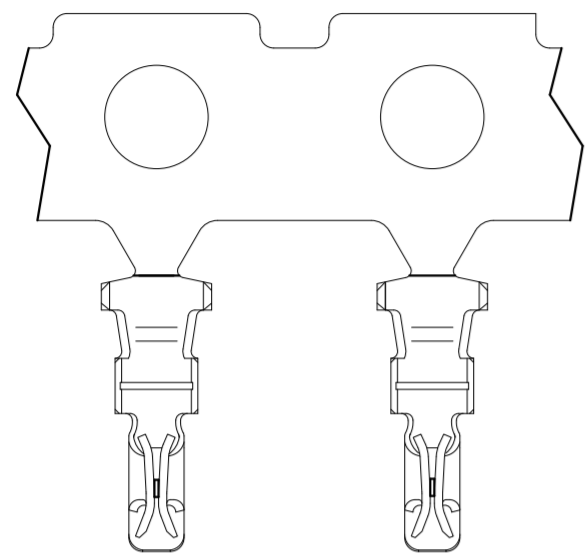

Product

Wrap on a paper disc

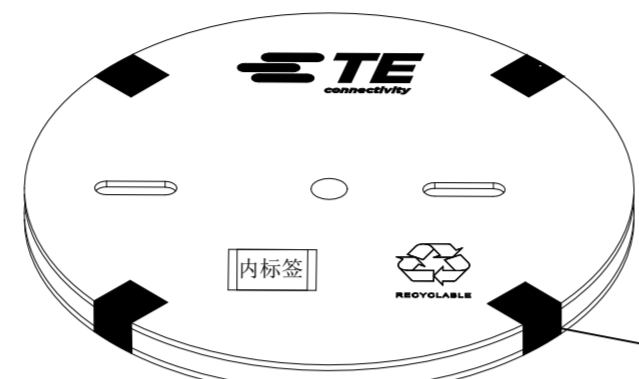

paper disc (ø480mm)

- 1.Wrap on a paper disc
- 2.The paper disc is sealed with tape
- 3.An inner label shall be affixed to the outer package

Packaging tape

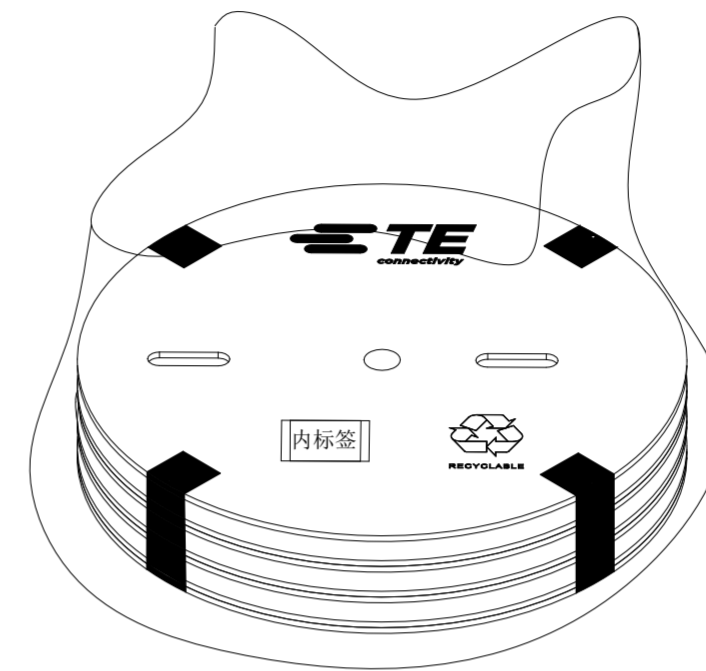

Encasement

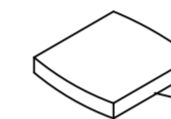

Desiccant



1.Label the outer box

Seal the box

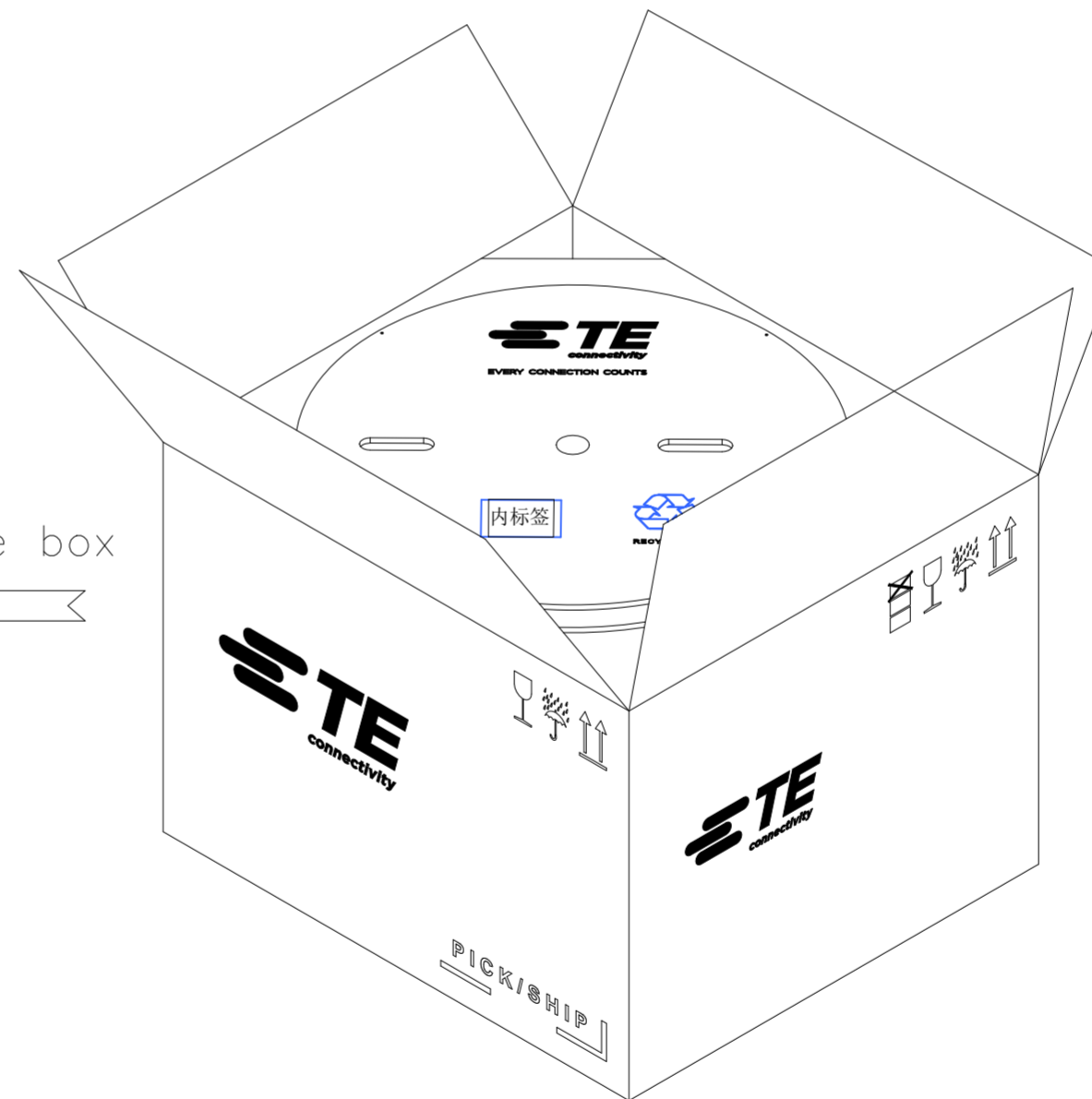

Box (48.8\*48.8\*12cm)

- 1.Put the terminals of each plate into the outer box and place them neatly
- 2.Put tripod around
- 3.Put two packets of desiccants in each box

Qty/reel	Qty/box
20,000 PCS	80,000 PCS

THIS DRAWING IS A CONTROLLED DOCUMENT.		DWN GOWTHAM 10APR2024	<b>TE</b> TE Connectivity	
DIMENSIONS: INCHES		CHK GOWTHAM 16MAY2022		
TOLERANCES UNLESS OTHERWISE SPECIFIED:		APVD SATHISH P S 16MAY2024	NAME 1mm WTB CONNECTOR	
0 PLC ± -		PRODUCT SPEC 108-161430	RESTRICTED TO	
1 PLC ± 0.02		APPLICATION SPEC 114-161064	SIZE A2	CAGE CODE 00779
2 PLC ± 0.10		MATERIAL -	DRAWING NO C-2484144	SCALE 1:1
3 PLC ± 0.05		FINISH -	WEIGHT 0	SHEET 2 of 2
4 PLC ± ± 2'		CUSTOMER DRAWING		
MATERIAL		REV A		