

P	LTR	DESCRIPTION	DATE	DWN	APVD
	A	REVISED PER ECN-24-299412	23DEC2024	SJ	VK

TOP VIEW

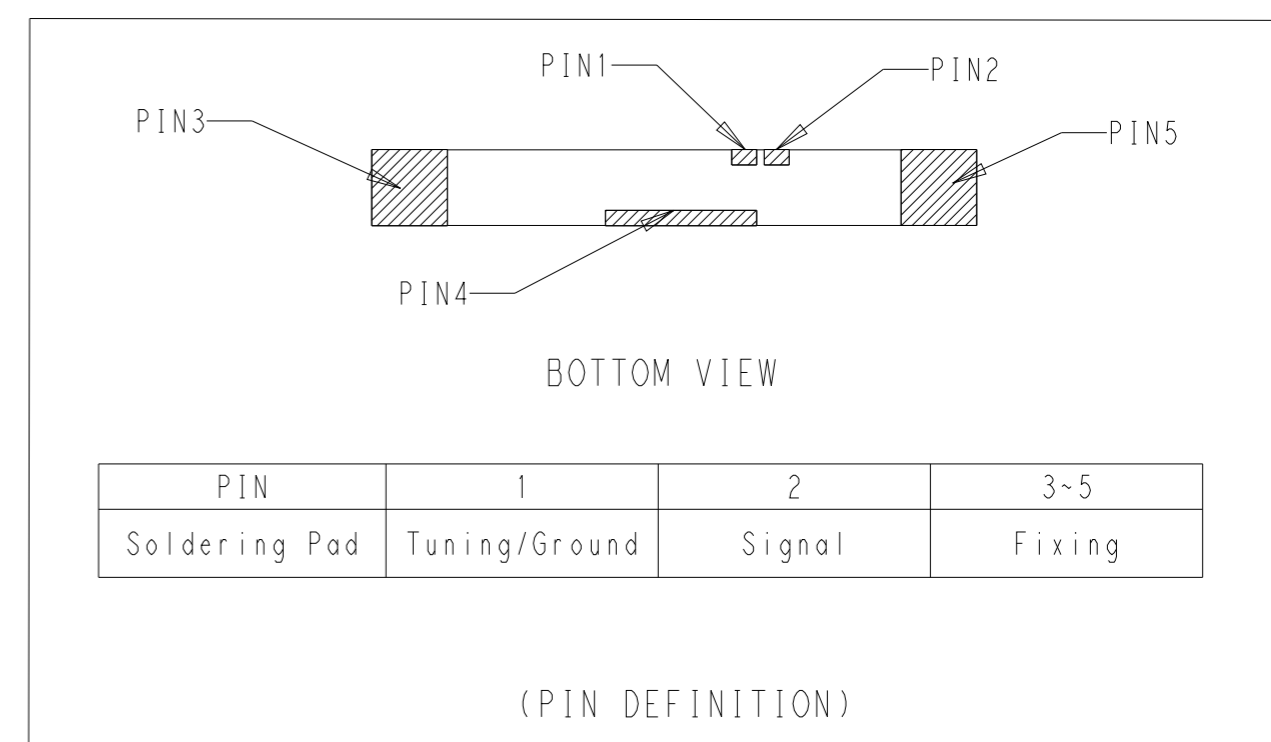
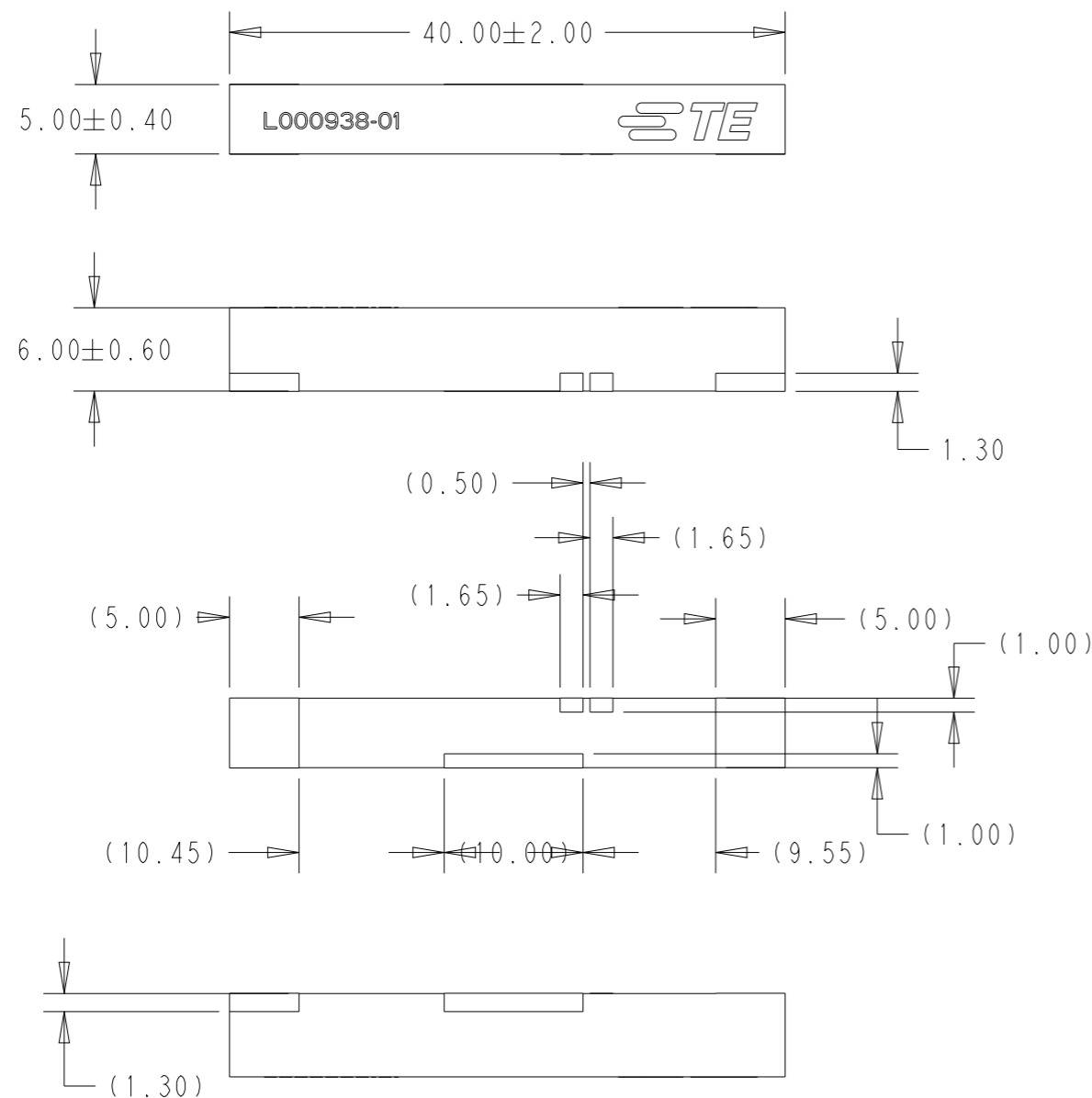

NOTES:

- MATERIAL: CERAMIC
- FINISH: Ag (ENVIRONMENTAL Pb FREE)
- ENVIRONMENTAL CONDITIONS
 OPERATION TEMPERATURE(°C): $-40^{\circ} \sim +85^{\circ}$
 STORAGE TEMPERATURE(°C): $-5^{\circ} \sim +40^{\circ}$
 RELATIVE HUMIDITY : 10~70%.
- GENERAL TOLERANCE IS ± 0.3 .
- PACKAGING: EMBOSSED TAPE AND REEL PACKAGED ON THE SHEET 2.
- CONSULT TE CONNECTIVITY DATA SHEET : L000938-01.

TAPE AND REELED	L000938-01
PACKAGING	PART NUMBER

THIS DRAWING IS A CONTROLLED DOCUMENT.		DWN	SJ.NOH	20MAY2024	TE Connectivity NAME CERAMIC ANT, SMD, 5G BAND 600-6000MHZ
DIMENSIONS: mm		CHK	-	20MAY2024	
TOLERANCES UNLESS OTHERWISE SPECIFIED:		APVD	JH.KIM	20MAY2024	
0 PLC \pm - 1 PLC ± 0.5 2 PLC ± 0.3 3 PLC \pm - 4 PLC \pm - ANGLES \pm -		PRODUCT SPEC	-	-	
MATERIAL CERAMIC		FINISH	-	-	APPLICATION SPEC
-		finish_spec_2	-	-	WEIGHT
-		-	-	-	CUSTOMER DRAWING
SIZE			A3	CAGE CODE	00779
DRAWING NO			G=L000938		RESTRICTED TO
SCALE			2:1	SHEET	1 OF 4
REV			A		

L000938-01 PACKAGING

REVISIONS					
P	LTR	DESCRIPTION	DATE	DWN	APVD
-	-	SEE SHEET 1	-	-	-

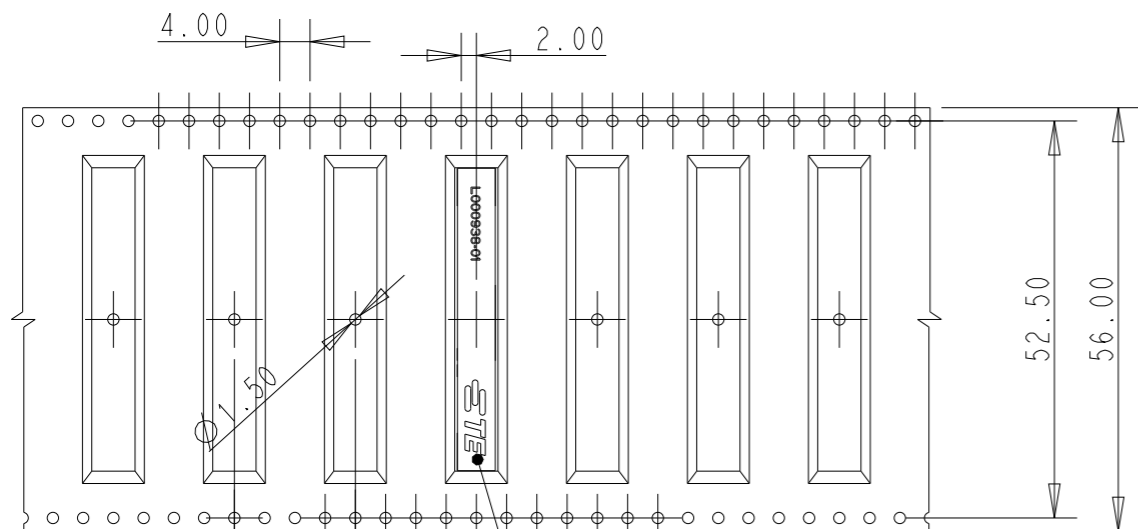

16.00
2
USER DIRECTION OF UNREELING

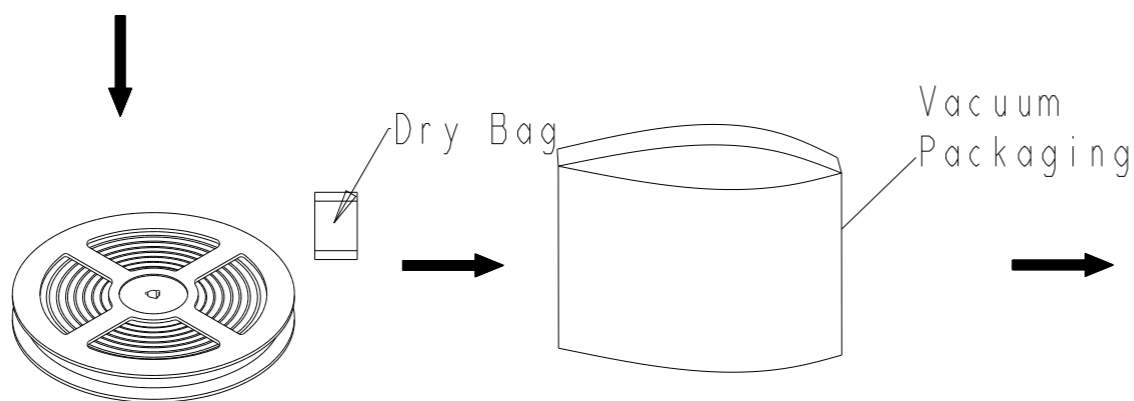

600 pcs / 1 Reel

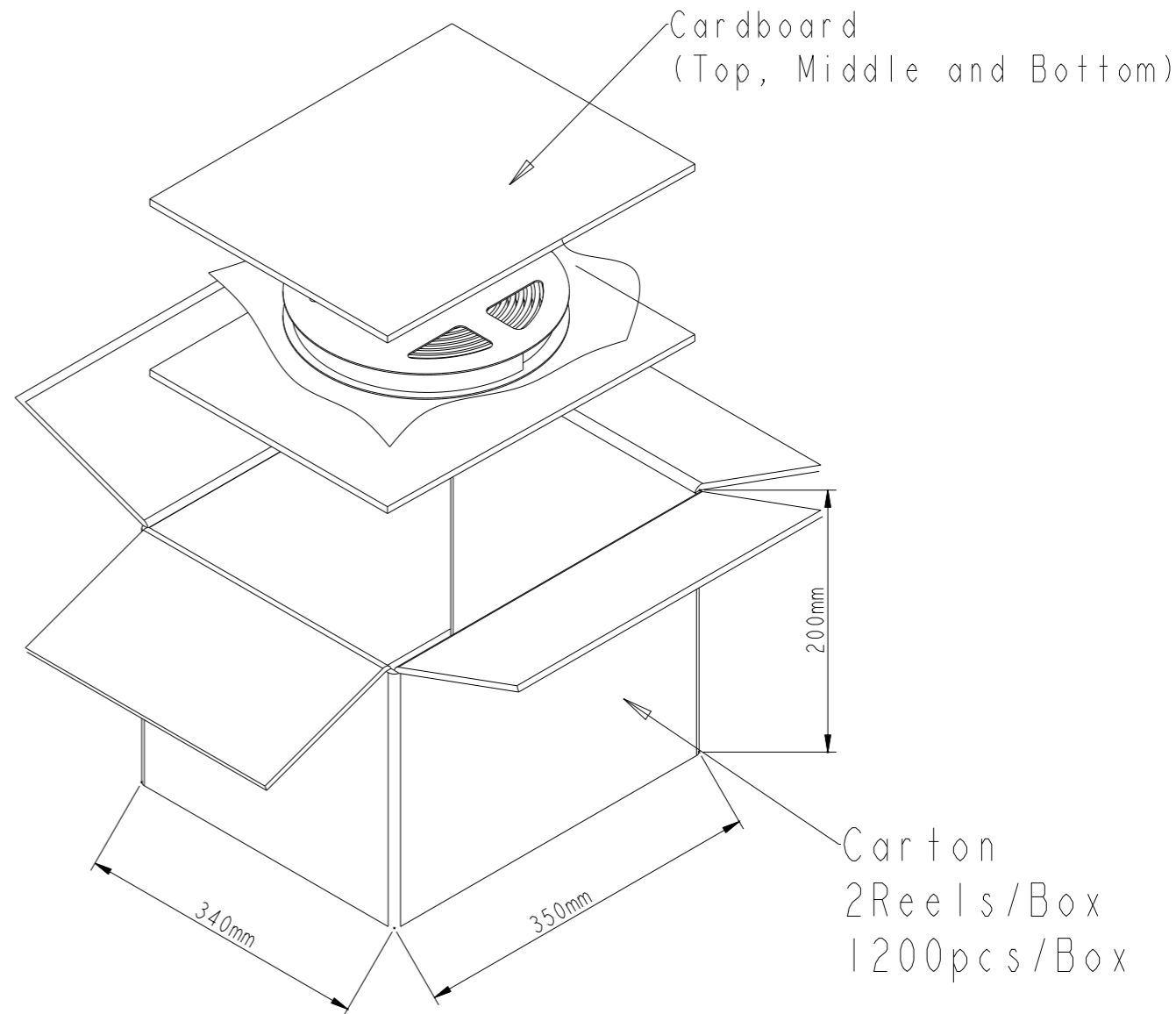

NOTES:

- UNLESS OTHERWISE SPECIFIED TOLERANCE PER EIA-481-D.
- ORIENT PARTS AS SHOWN.
(CHIPS BLACK MARK IS ON THE SAME SIDE AS THE ROUND HOLE)
- MATERIAL : CAREER TAPE : PS
COVER TAPE : PET
PLASTIC REEL : PS (CONDUCTIVE)
- PACKAGING Q'TY : 600 / REEL

THIS DRAWING IS A CONTROLLED DOCUMENT.		DWN SJ.NOH	20MAY2024	TE Connectivity	
DIMENSIONS: mm		CHK -	20MAY2024		
TOLERANCES UNLESS OTHERWISE SPECIFIED:		APVD JH.KIM	20MAY2024	NAME CERAMIC ANT, SMD, 5G BAND 600-6000MHZ	
0 PLC ±- 1 PLC ±0.5 2 PLC ±0.3 3 PLC ±- 4 PLC ±- ANGLES ±-		PRODUCT SPEC -		APPLICATION SPEC -	
MATERIAL CERAMIC		WEIGHT -		SIZE A3	CAGE CODE 00779
FINISH -		CUSTOMER DRAWING		DRAWING NO C=L000938	RESTRICTED TO -
finish_spec_2		SCALE 2:1		SHEET 2 OF 4	REV A

P	LTR	DESCRIPTION	DATE	DWN	APVD
-	-	SEE SHEET 1	-	-	-

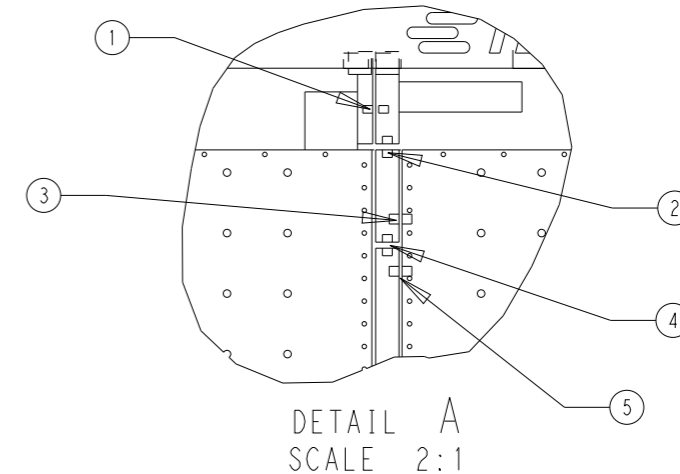
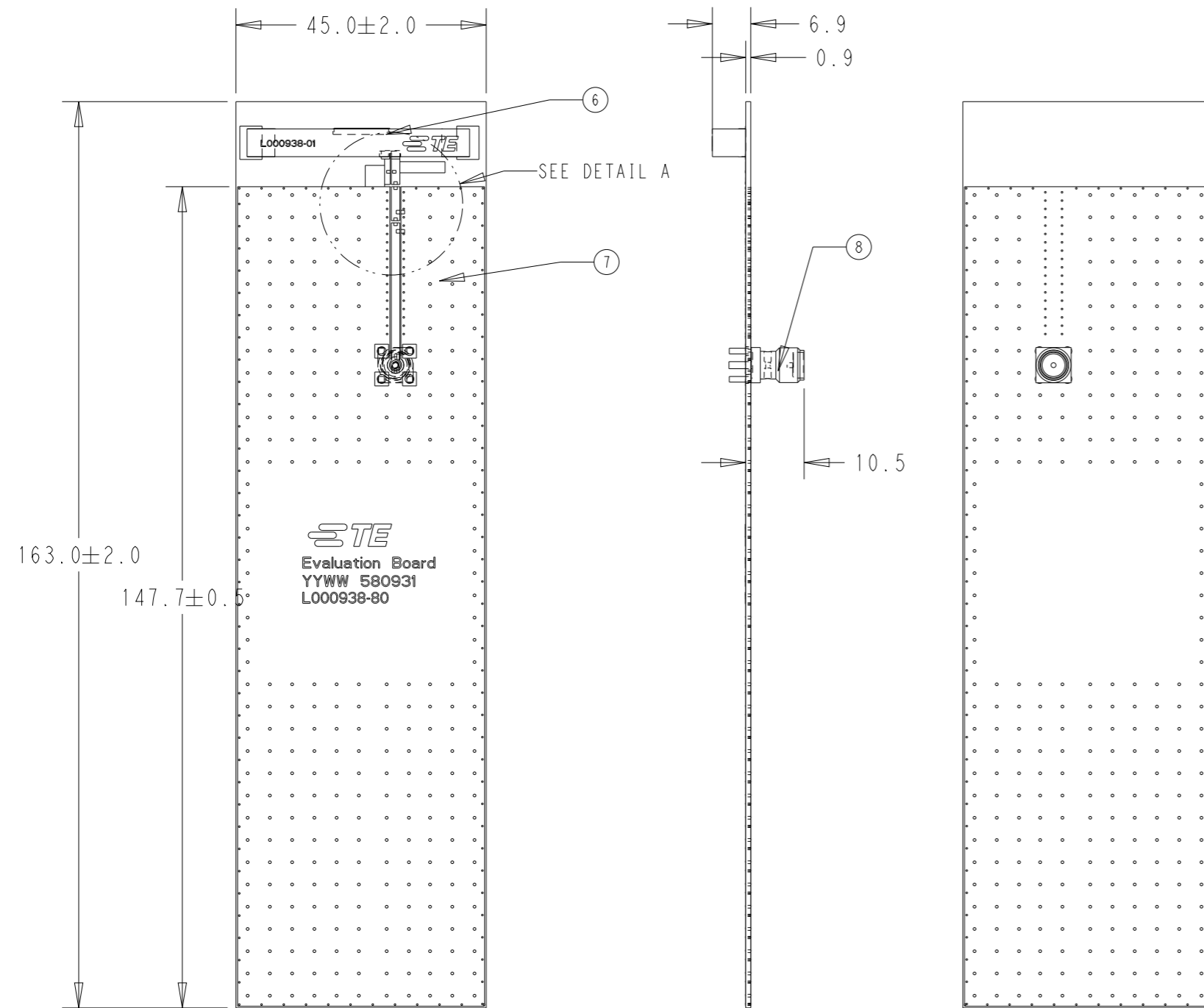

STE
Evaluation Board
YYWW 580931
L000938-80

AS SHOWN L000657-80

BULK IN PE BAG		L000938-80	
PACKAGING		PART NUMBER	
I		SMA PCB VERT CONNECTOR	8
I	FR-4	EVALRATION BORD(BLACK)	7
I	CERAMIC	CERAMIC ANTENNA	6
	N/C		5
I	C	0Ω(0402 Walsin)	4
	N/C	-	3
I	C	6.8pF(0402 MURATA)	2
I	L	6.8nH(0402 MURATA)	1
QTY	MATERIAL	DESCRIPTION	ITEM

THIS DRAWING IS A CONTROLLED DOCUMENT.		DWN	SJ.NOH 20MAY2024		TE Connectivity CERAMIC ANT, SMD, 5G BAND 600-6000MHZ								
DIMENSIONS: mm		CHK	20MAY2024										
TOLERANCES UNLESS OTHERWISE SPECIFIED:		APVD	JH.KIM 20MAY2024										
0 PLC ±- 1 PLC ±0.5 2 PLC ±0.3 3 PLC ±- 4 PLC ±- ANGLES ±-		PRODUCT SPEC	-										
MATERIAL CERAMIC		FINISH	-		APPLICATION SPEC	-							
-		finish_spec_2	WEIGHT	-		SIZE	A3	CAGE CODE	00779	DRAWING NO	©-L000938	RESTRICTED TO	-
CUSTOMER DRAWING			SCALE	2:1		SHEET	3 OF 4		REV	A			

L000938-80 PACKAGING

REVISIONS

P	LTR	DESCRIPTION	DATE	DWN	APVD
-	-	SEE SHEET 1	-	-	-

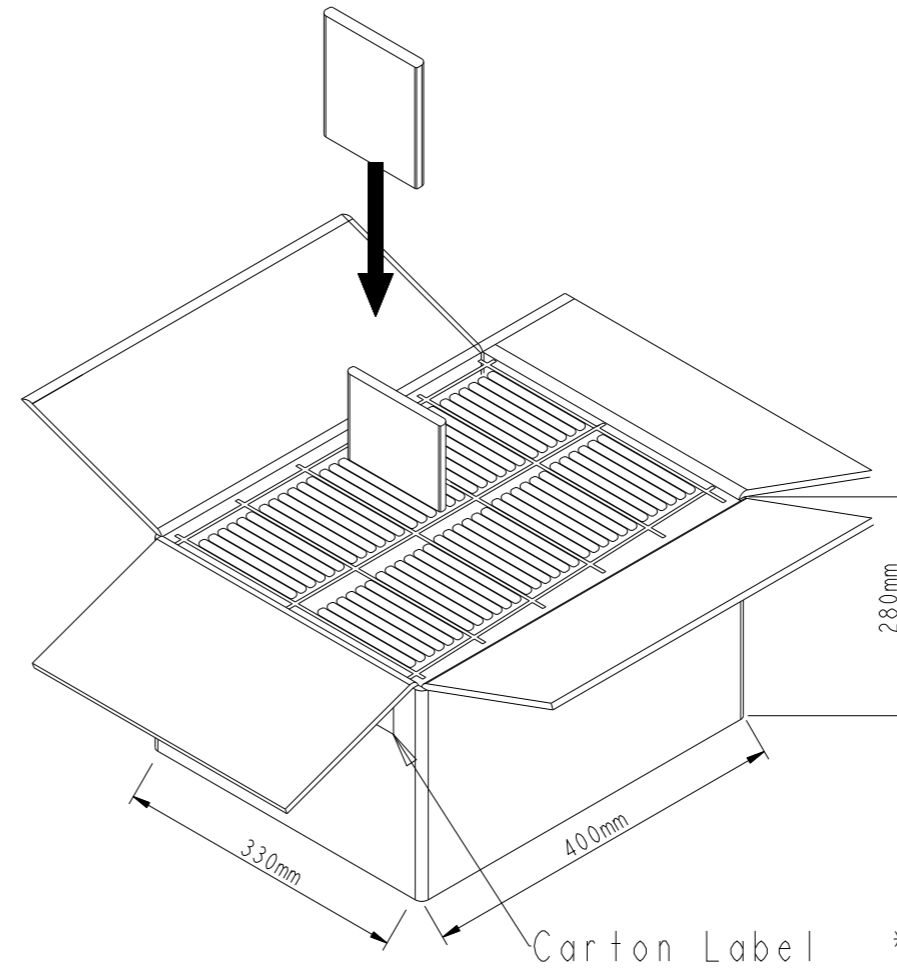
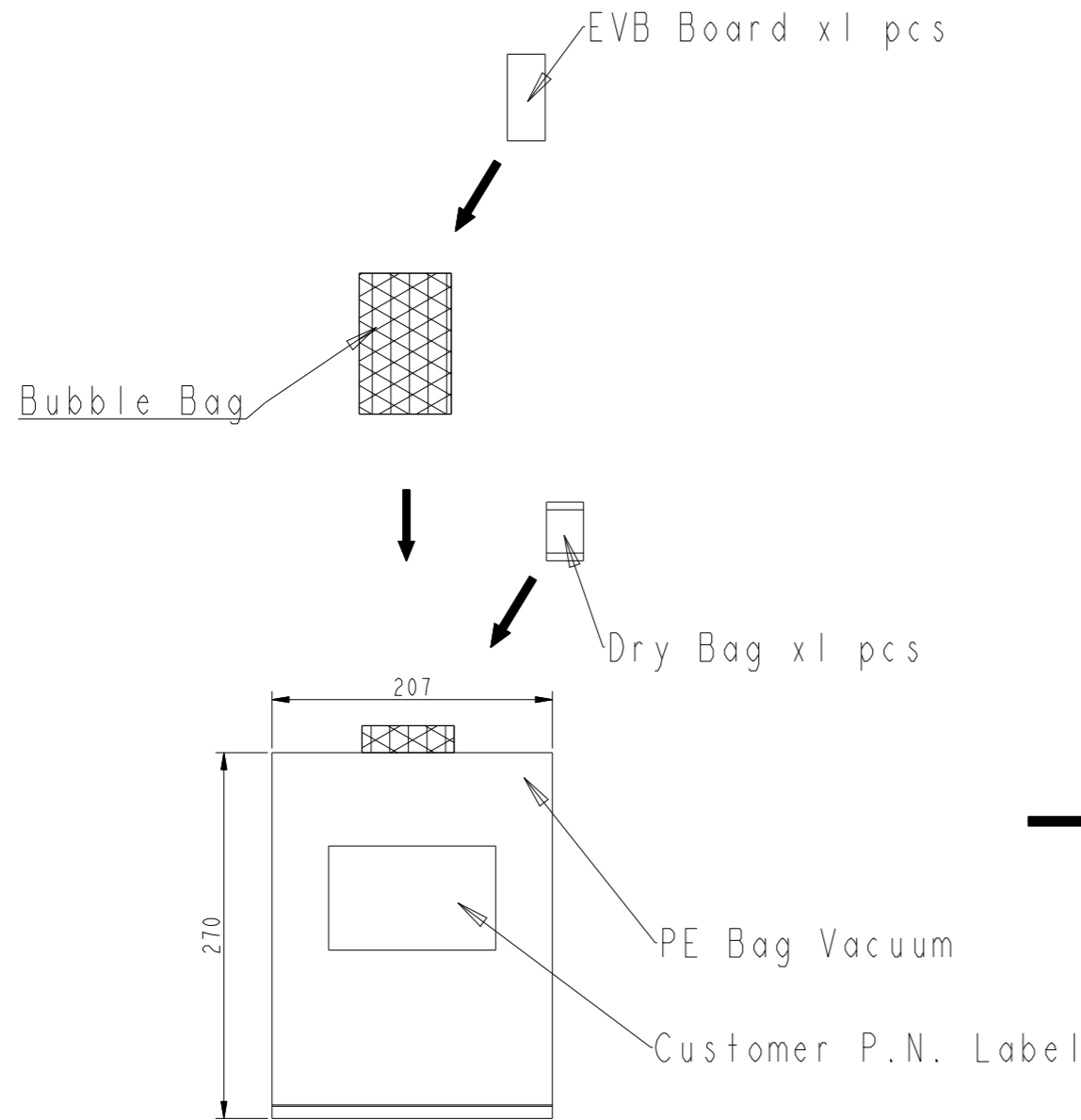

- 1 PE Bag
- = 1 pc EVB Board

- 1 Carton
- = 60 PE Bags
- = 60 pcs EVB Board

*Buffer Filling Of Product Packaging

THIS DRAWING IS A CONTROLLED DOCUMENT.		DWN SJ.NOH	20MAY2024	TE Connectivity	
DIMENSIONS: mm		CHK -	20MAY2024		
TOLERANCES UNLESS OTHERWISE SPECIFIED:		APVD JH.KIM	20MAY2024	NAME CERAMIC ANT, SMD, 5G BAND 600-6000MHZ	
0 PLC ±- 1 PLC ±0.5 2 PLC ±0.3 3 PLC ±- 4 PLC ±- ANGLES ±-		PRODUCT SPEC -		RESTRICTED TO -	
MATERIAL CERAMIC		APPLICATION SPEC -		SIZE A3	CAGE CODE 00779
FINISH -		WEIGHT -		DRAWING NO C=L000938	
-		CUSTOMER DRAWING		SCALE 2:1	SHEET 4 OF 4
-		finish_spec_2		REV A	