

REV	DESCRIPTION	DATE	DWN	APVD
-----	-------------	------	-----	------

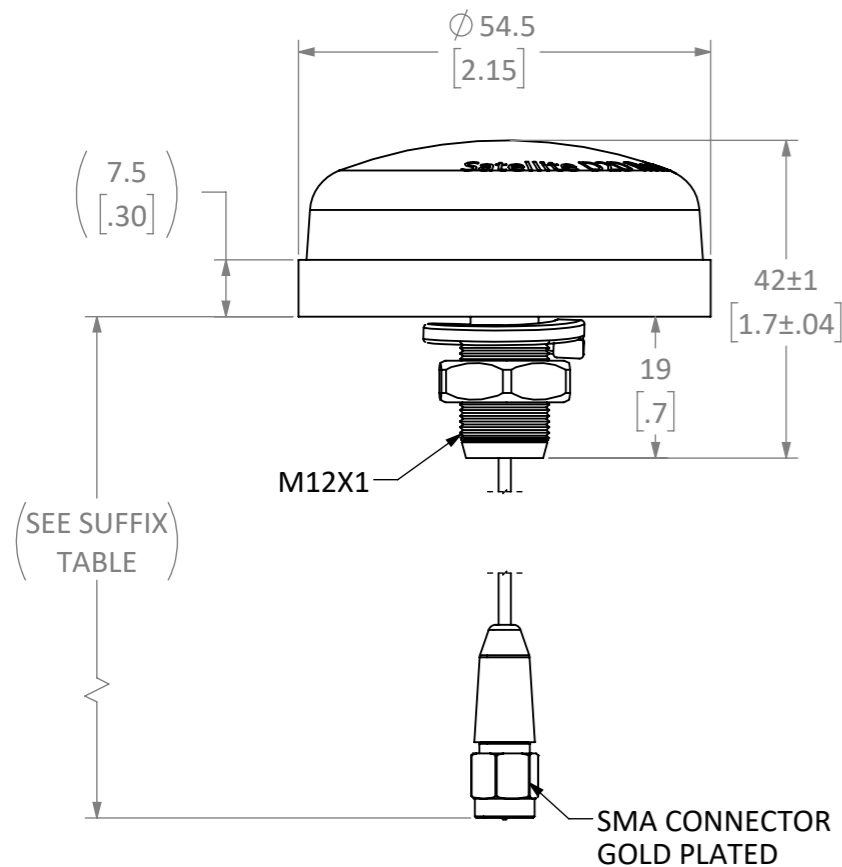

• FONT TYPE : Gotham
 • LETTER SPACING : 0
 • COLOR :
CMYK C 0 M 52 Y 100 K 0
Pantone 144C
RGB 242 R 141 G 0 B
Hex #f28d00

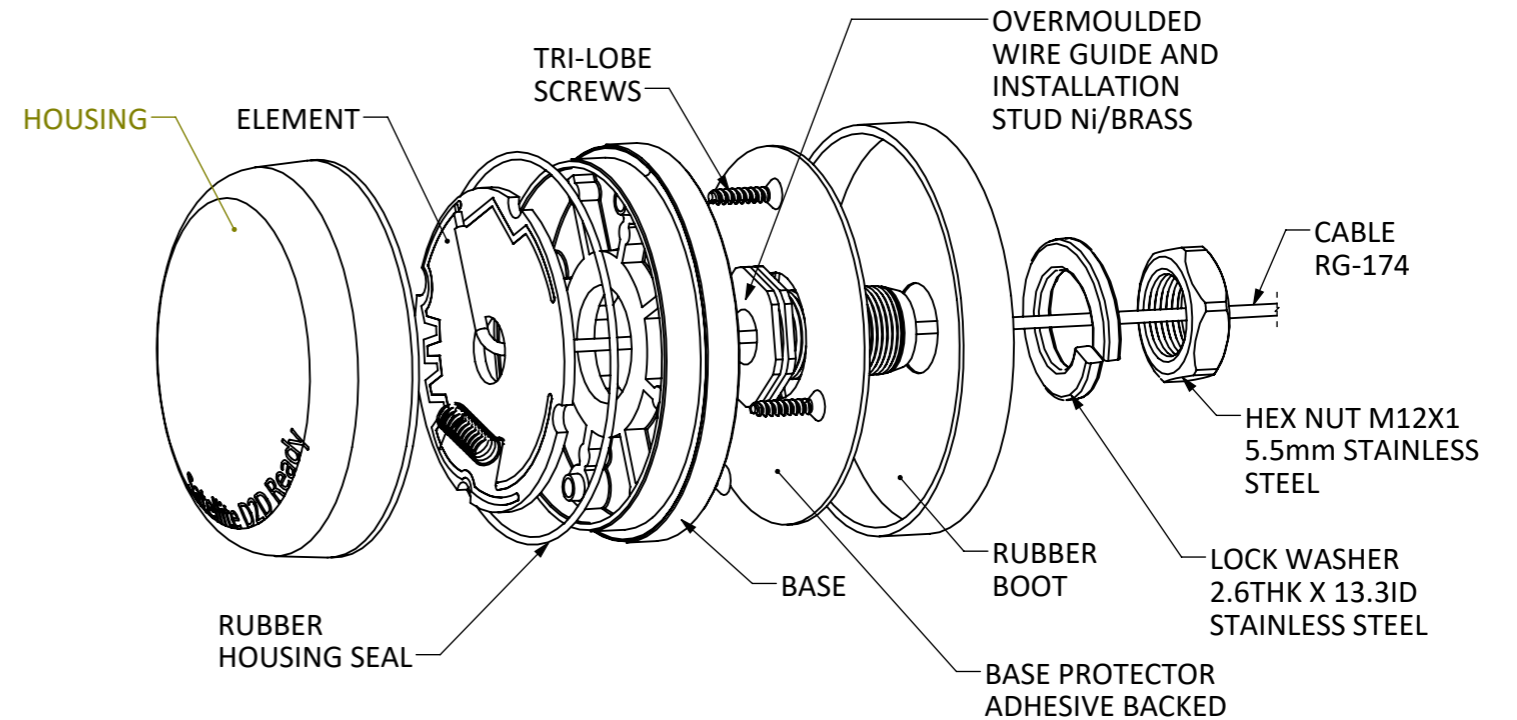
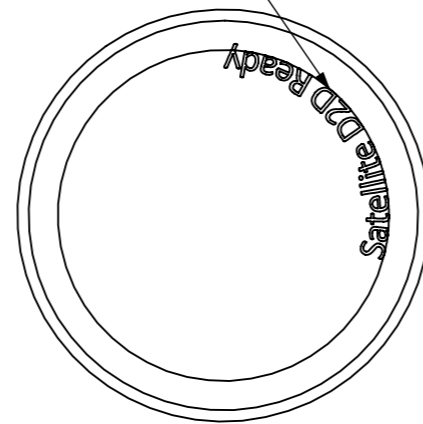

- NOTES: (UNLESS OTHERWISE SPECIFIED)
1. ALL DIMENSIONS ARE IN MILLIMETERS [IN].
 2. DIMENSIONS APPLY AFTER FINISHING.
 3. MANUFACTURE TO BE COMPLIANT WITH EU RoHS DIRECTIVE, USE MATERIALS THAT DO NOT CONTAIN REACH SUBSTANCES OF VERY HIGH CONCERN >1000ppm, AND USE DRC CONFLICT-FREE SOURCED MATERIALS.
 4. SMA PLUG TYPE CONNECTOR INTERFACE SHALL CONFORM TO MIL-STD-348B. CONNECTOR FINISH GOLD.
 5. CABLE TYPE: RG174U
 6. ENVIRONMENTAL: IP67 WATERPROOF SEALED ELEMENT AND MOUNTING BASE.
 7. HOUSING MATERIAL: POLYCARBONITE, BLACK UV STABLE
 8. OPERATING TEMPERATURE: -40°- 70° C
 9. MAX SMA CONNECTION TORQUE: NTE .9N-m [8in-lbs]
 10. MAX TORQUE: 25N-m [16ft-lbs.]
 11. MAX BULKHEAD THICKNESS: 3.89mm [.254in]
 12. ALL GEOMETRY AND FEATURES CONTROLLED BY MODEL AT LATEST REVISION.

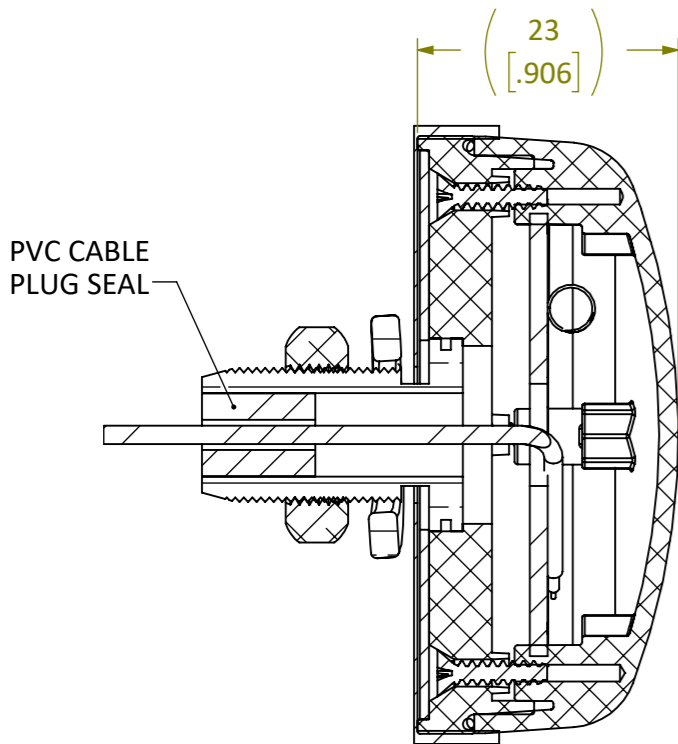

BULKHEAD INSTALLATION HOLE GEOMETRY

SUFFIX	CABLE LENGTH
-01	1.0M ± 25mm

THIS DRAWING IS A CONTROLLED DOCUMENT.		DWN	JHAGER	12/23/20		TE Connectivity			
DIMENSIONS:		CHK	DASARATHAN	12/23/20		NAME			
mm		APVD	DASARATHAN	12/23/20		5G CELLULAR ANT PUCK			
		PRODUCT SPEC	-			RG174 SMA 433/868/915MHz			
TOLERANCES UNLESS OTHERWISE SPECIFIED:		APPLICATION SPEC	-			SIZE	CAGE CODE	DRAWING NO	RESTRICTED TO
0 PLC ±		WEIGHT	-			A3	00779	C=L001266	
1 PLC ±		CUSTOMER DRAWING		SCALE	1:1	SHEET		1 OF 1	
2 PLC ±								REV	
3 PLC ±									
4 PLC ±									
ANGLES ±°									
MATERIAL									
ABS, PLASTIC									
-									