

REVISIONS

REV	DESCRIPTION	DATE	DWN	APVD
A	CHANGE TO TE DRAWING FORMAT	23JUL25	PK	C HANG

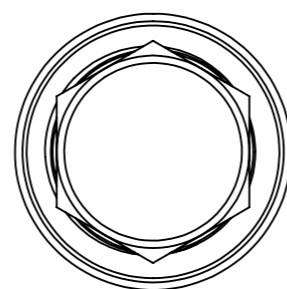
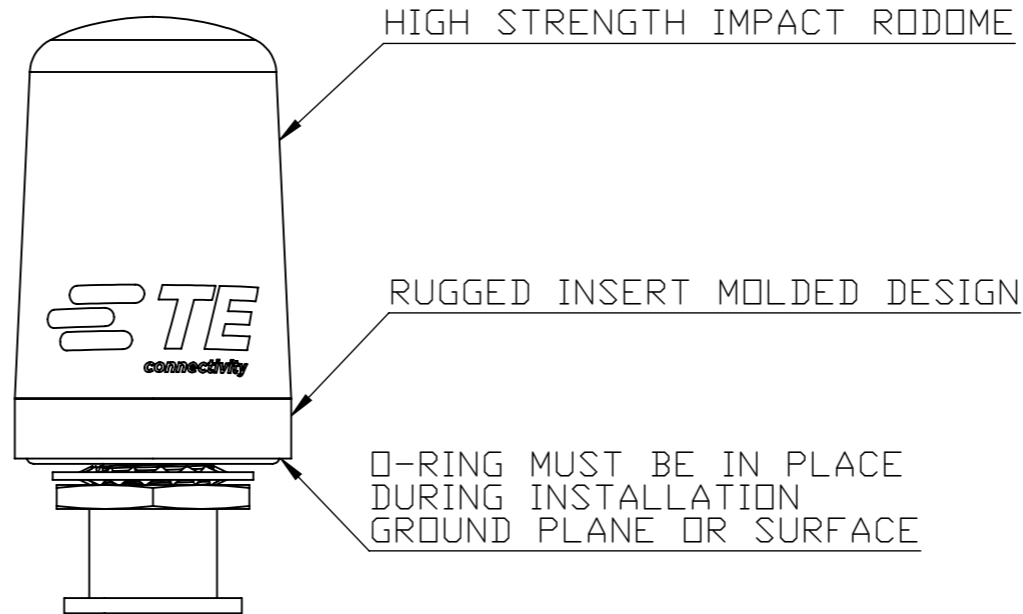

PARAMETER	PERFORMANCE
MODEL NUMBER	REFER TO CONFIG TABLE
ANTENNA TYPE	MONOPOLE
VSWR	< 2:1
INPUT IMPEDANCE	50 OHM
POLARIZATION	VERTICAL
ANTENNA COLOR	REFER TO CONFIG TABLE
GROUND PLANE	TESTED ON 2FT X 2FT GP FOR GP MODELS
WEIGHT	184.1G (P-MOUNT)
MOUNTING	REFER TO CONFIG TABLE
WIND SURVIVOL	282 km/H
OPERATING TEMPERATURE	-45°C ~ +85°C
STORAGE TEMPERATURE	-50°C ~ +85°C
INGRESSION PROTECTION	IP67
FREQUENCY RANGE	2400 - 2500 MHZ
INSTALLATION TORQUE	5.43~8.14 NM

THIS DRAWING IS A CONTROLLED DOCUMENT.		DWN TP CHEE 06JUN2012				
		CHK YJ TEQH 06JUN2012				
		APVD C.HANG 06JUN2012	NAME			
		PRODUCT SPEC N/A	OMNI,Ph,2400-2500MHZ 3,P MT BLK			
		APPLICATION SPEC N/A	SIZE	CAGE CODE	DRAWING NO	RESTRICTED TO
		WEIGHT REFER TABLE	A3	00779	©-TRAB24003P	
CUSTOMER DRAWING		SCALE 1:1		SHEET 1 OF 1	REV A	

DIMENSIONS: mm	TOLERANCES UNLESS OTHERWISE SPECIFIED:
	0 PLC ± 0.5
	1 PLC ± 0.25
	2 PLC ± 0.13
	3 PLC ±
	4 PLC ±
ANGLES ± 30'	
MATERIAL N/A	FINISH N/A