

DESCRIPTION	PART NUMBER	SPECIFICS
Plug Housing Assembly, GPEC II	1924939	Key A – Right Exit
	1924940	Key A – Left Exit
	1924941	Key C – Right Exit
	1924942	Key C – Left Exit
	1924943	Key E – Right Exit
	1924944	Key A – Left Exit
Plug Housing Assembly GPEC III	2098863	Key G – Right Exit
	2098864	Key G – Left Exit
	2098865	Key H – Right Exit
	2098866	Key H – Left Exit
Wire Dress Assembly, Straight	1924779-1	May Be Used For Right or Left Exit
Wire Dress Assembly - 90° Right	2098489-1	May Be Used For Right or Left Exit
Wire Dress Assembly - 90° Left	2098491-1	May Be Used For Right or Left Exit
Wire Dress Assembly - 45° x 45°	2098681-1	May Be Used For Right or Left Exit
Wire Dress Assembly – Low Profile	2035027-1	May Be Used For Right or Left Exit
Optional Blind Plugs	284583-1	Yellow 18-22 AWG
	1-1452424-2	Blue 16-20 AWG
GET Terminals	1393364-1	Gold Plated 22 AWG
	1393365-1	Gold Plated 18-20 AWG
	1924878-1	Tin/Silver 22 AWG
	1924879-1	Tin/Silver 18-20 AWG
	1924880-1	Tin/Silver 16 AWG
	1924782-1	Tin/Silver 1.0 mm ²

Figure 1

1. INTRODUCTION

This instruction sheet provides information on terminal insertion and extraction, and repair and replacement procedures for the 96-Position GPEC II and III Sealed Connector System. These instructions also cover installation of a wire cover which is used to protect the wires. Saleable part numbers associated with this connector system are provided in Figure 1. Read this document thoroughly prior to assembly procedures.

This plug assembly mates with a printed circuit board header assembly.

i **NOTE**
Dimensions in this instruction sheet are in millimeters [with inches in brackets]. Figures and illustrations are for reference only and are not drawn to scale.

2. DESCRIPTION

The plug connector assembly contains a plug housing, a plug assembly (TPA) Terminal Position Assurance (secondary lock), plug assembly gasket, slides, seal, seal cover, wire dress, terminals, and optional blind plugs. Some of these components may be pre-assembled prior to shipment.

3. ASSEMBLY PROCEDURES

Refer to Instruction Sheet [408-10230](#) for Mating and Unmating Procedures for the 96-Position GPEC II Sealed Connector System.

3.1. Wire Selection and Preparation

Circuits used in this connector system will accept contacts with 18-22 or 16-20 AWG wire. The connector assembly will accept 24 of the 16-20 AWG wire size terminals, while the remaining 72 positions will accept 18-22 wire size terminals. The allowable wire insulation ranges for 22-18 AWG wire sizes are 1.20 to 2.06 mm; and for 20-16 AWG wire sizes, the insulation range allows 1.40 to 2.40 mm. This information can be found on the GPEC Customer Connector Assembly Drawing. Refer to Application Specification [114-13236](#) for specific wire preparation and contact termination requirements.

3.2. Terminal Insertion

i **NOTE**
Make sure all terminals are properly crimped and appear as shown in Figure 2.

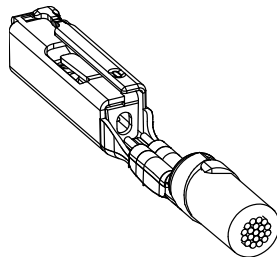

Figure 2

i **NOTE**
For 1.5 mm² [16 AWG] applications, no front bellmouth is permitted. Front bellmouth with 1.5 mm² [16 AWG] crimps may be difficult to insert into plastic housing.

i **NOTE**
Lower terminal row is oriented 180° from upper terminal row as shown in Figure 3.

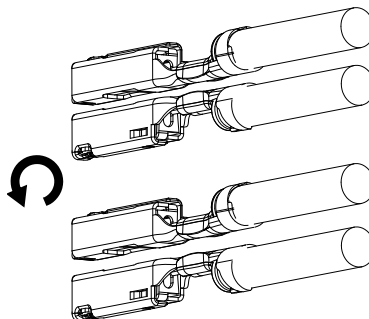

Figure 3

Insert terminals straight into the cavities as shown in Figure 4 until an audible or tactile click is heard or felt.

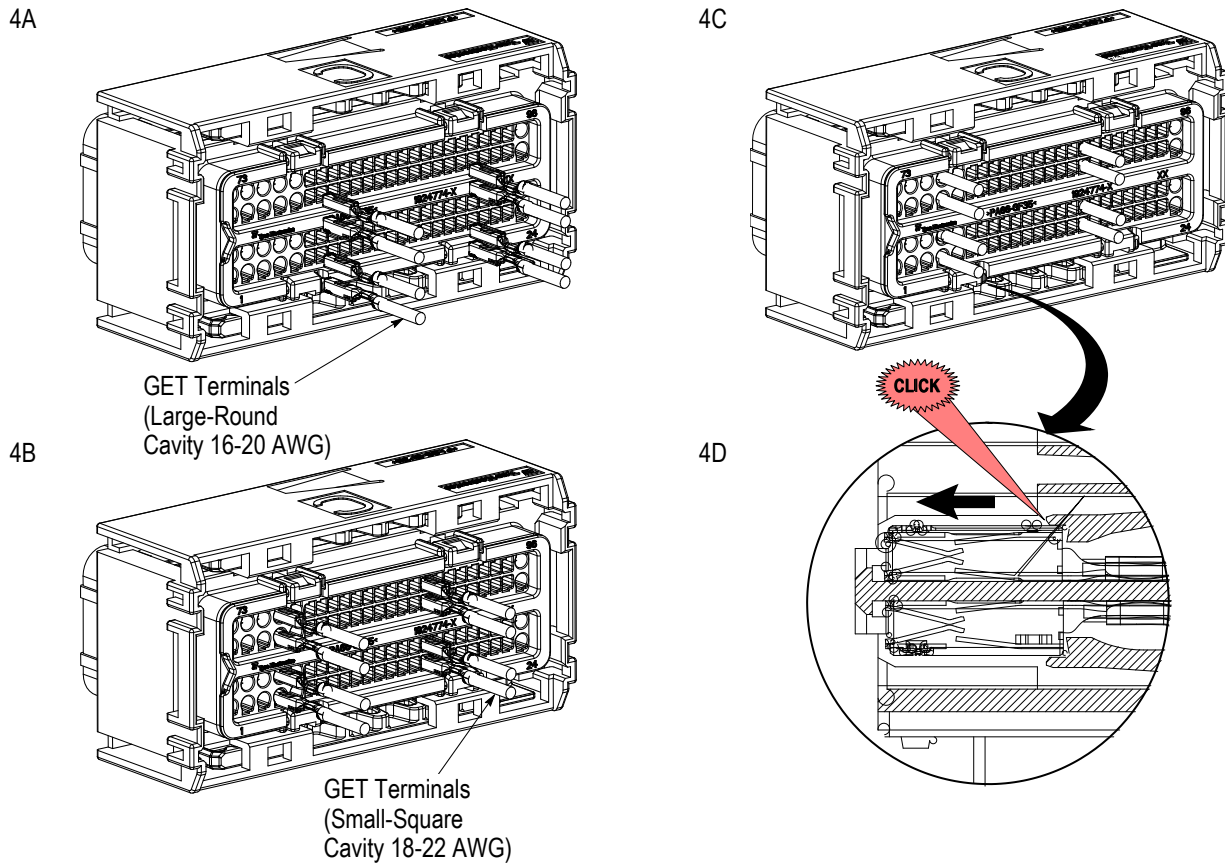

Figure 4



CAUTION

Make sure to follow the position of terminals provided in Figure 3 with the proper wire size range to prevent incorrect insertion of terminals.



NOTE

Gently pull on wire to ensure terminal has been latched in position.

3.3. TPA Seating



NOTE

Before inserting contacts into the harness assembly, be sure that the TPA is in the “open-preset” position. See Figure 5A.

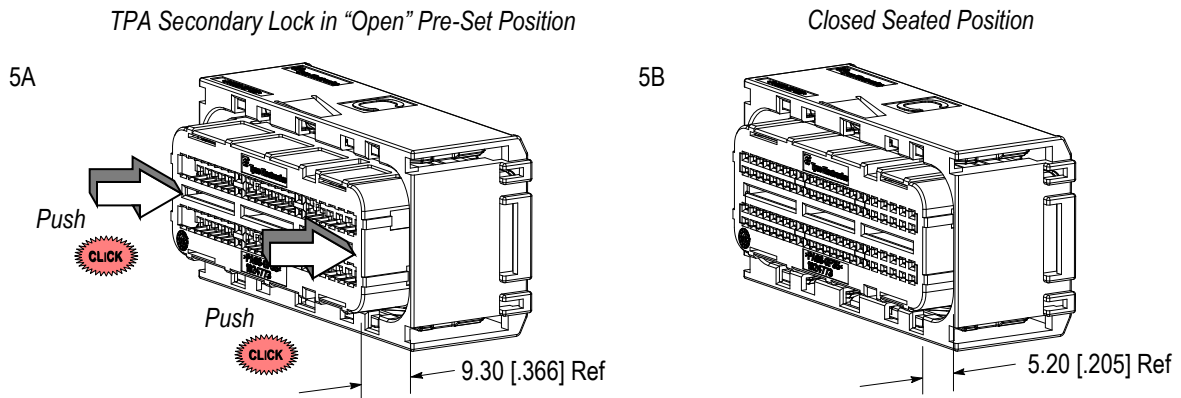

Figure 5

After all terminal contacts are inserted, engage the TPA secondary lock. A physical resistance to fully engaging TPA indicates contact(s) is not fully inserted. Reset the TPA to its pre-set position, and go back to Terminal Insertion, Paragraph 3.2.

Push on the TPA evenly with your thumbs on each end. Push until an audible and tactile “click” is heard and felt. The TPA secondary lock will be in the final position. See Figure 5B.

3.4. Wire Dress Installation



NOTE

The wire dress lever **MUST** be in the LOCKED position prior to assembly with the plug assembly and may be used for either right or left exit.

Guide the rear of the wire dress into the plug housing assembly slots and rotate into position until it snaps into place. An audible and tactile “click” will be heard and felt when assembly is completed. See Figure 6.



NOTE

Cable ties may be used at the end of the wire dress to hold wires in place. A small cable tie can be placed in the slots while a large cable tie would go completely around the wire dress end.

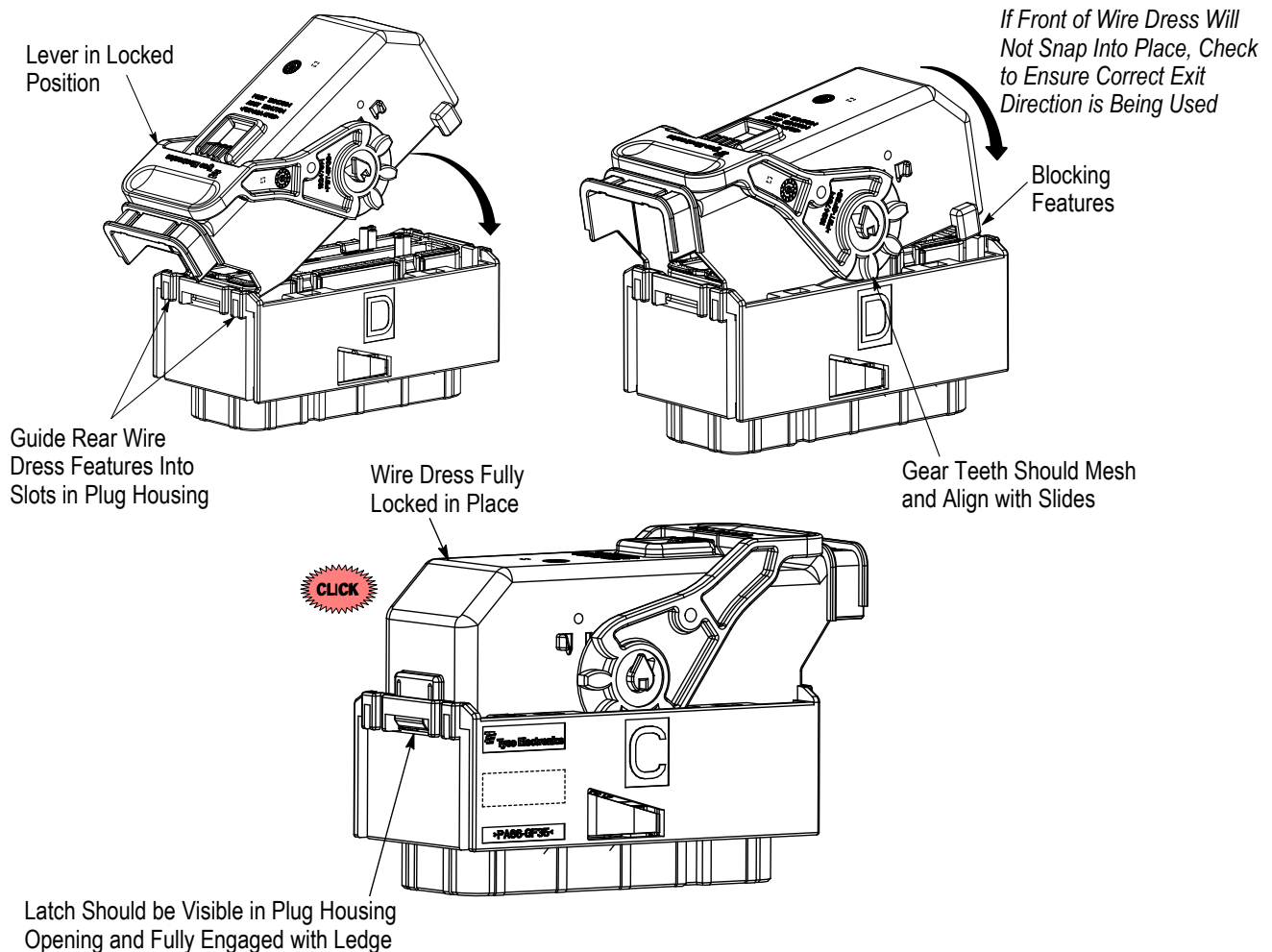

Figure 6

3.5. Blind Plug Installation

Optional blind plugs are provided for use when circuits are not being used to seal them from external elements. Both blind plugs are color-coded as noted in Figure 7. Blind plugs are correctly inserted when bottomed in circuit cavity. Plugs may be used for prototype or field service use.

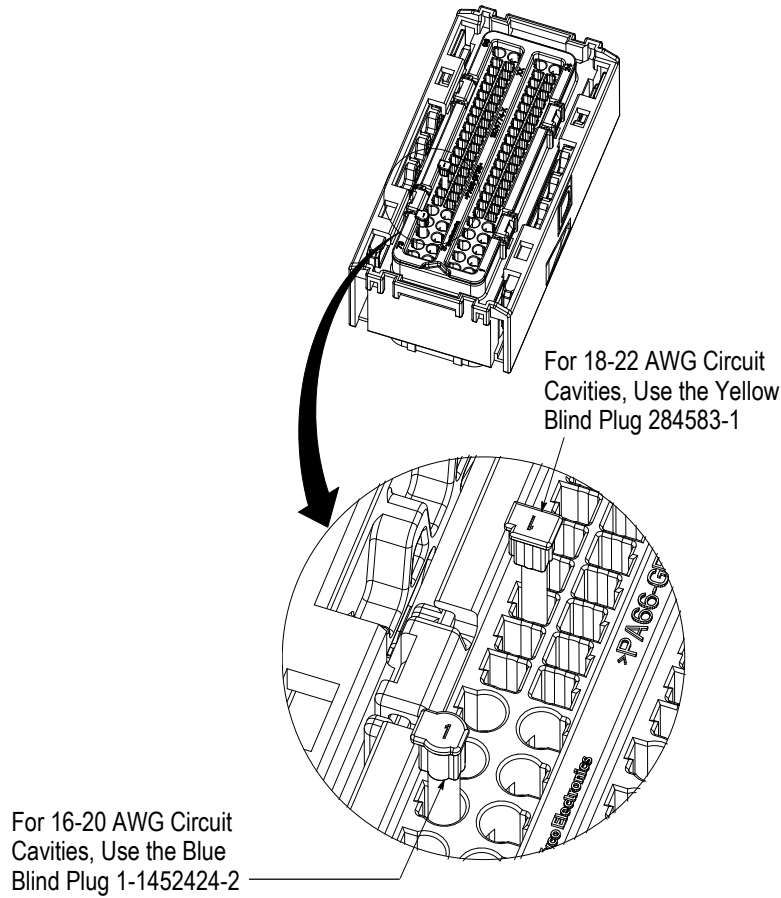

Figure 7

4. DISASSEMBLY PROCEDURES

1. To disassemble this connector system, first cut and remove the cable tie if present.
2. Insert screwdriver to release wire dress latch and rotate up to remove wire dress from the plug assembly. See Figure 8.

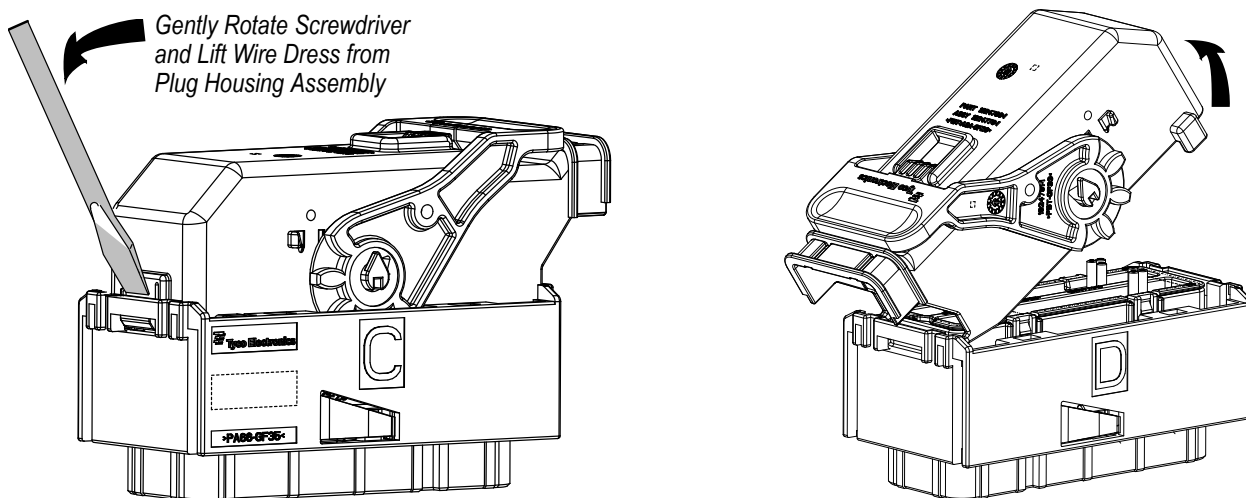

Figure 8

3. Remove the TPA from the plug assembly by placing a small screwdriver in the ends and rotating to pry up the TPA from the plug assembly. See Figure 9.

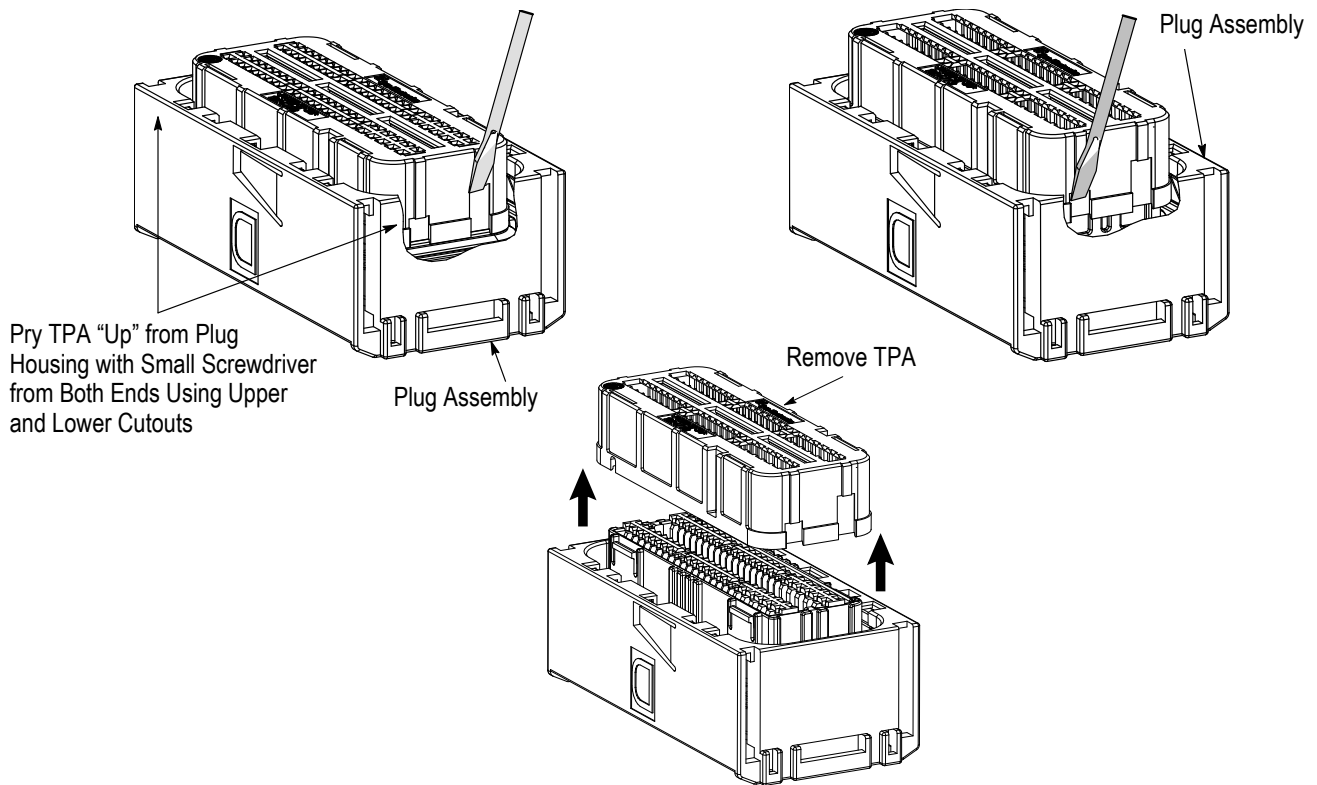

Figure 9

4. Once the TPA has been removed, insert Extraction Tool 1393477-6 into front of plug housing assembly in the correct position to unlatch the locking lance of the socket contact as shown in Figure 10.
5. Once the locking lance has been lifted up, simultaneously pull gently on the wire, from the rear, to remove contact and wire. See Figure 10.

5. REPAIR/REPLACEMENT



CAUTION

Damaged product should not be used. If a damaged contact is evident, it should be replaced. Contacts must not be re-terminated. If a damaged TPA, wire dress, or plug assembly is evident and may impair signal transmission, it should also be replaced.

6. REVISION SUMMARY

- Updated document to corporate requirements
- Changed dimensions in Paragraph 3.1

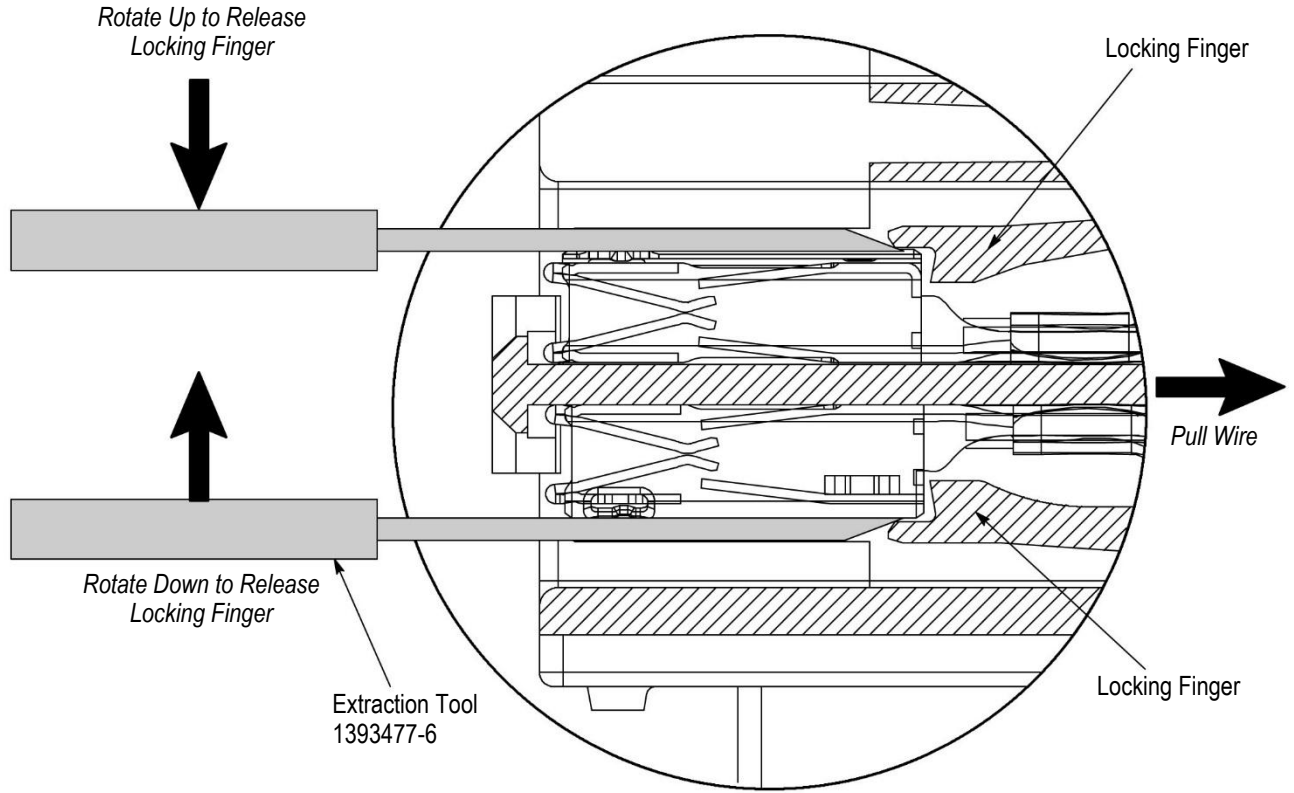

Figure 10