

LOC	DIST	REVISIONS			
REV	DATE	DESCRIPTION	DATE	BY	APP'D
A	08AUG96	REV: EC 0210-0510-96	08AUG96	DS	DW
B	17JUL06	REV-ECO-06-017000	17JUL06	LH	SH

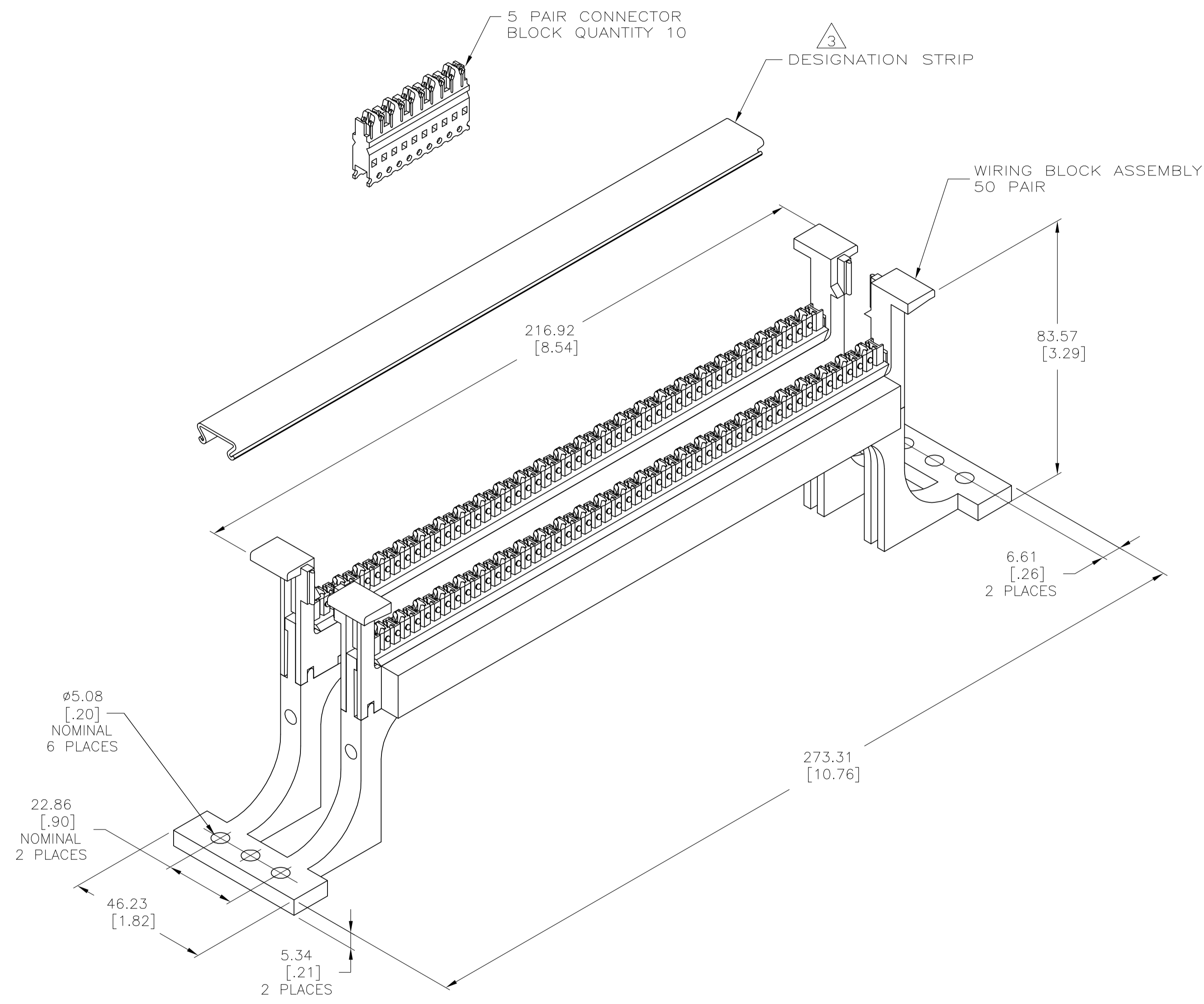

- 1. DIMENSIONS ARE MAXIMUM UNLESS OTHERWISE SPECIFIED.
- 2. MATERIAL: WIRING BLOCK ASSEMBLY AND CONNECTOR BLOCK- POLYCARBONATE MOLDING COMPOUND, FLAME RETARDANT, IVORY.
DESIGNATION STRIP- RIGID PVC, CLEAR.
TERMINALS- PHOSPHOR BRONZE PLATED WITH 3.81 [.000150] MINIMUM BRIGHT MATTE-TIN OVER 1.27μm [.000050] MINIMUM NICKEL UNDERPLATE.
- 3. WHITE, DESIGNATION STRIP LABEL NOT SHOWN.
- 4. PACKAGE ONE KIT PER POLYBAG.
- 5. LACING STRIPS MARKED BLACK EVERY FIFTH PAIR.

569434-1
PART NO.

THIS DRAWING IS A CONTROLLED DOCUMENT.		DWG L. SMITH 9-19-95	Tyco Electronics Corporation Harrisburg, Pa 17105-3608	
DIMENSIONS: mm [INCHES]		CHK B. FOX 11-01-95	APPROVED D. WILLIAMS 11-01-95	
TOLERANCES UNLESS OTHERWISE SPECIFIED:		NAME 110 CROSS CONNECT KIT, 50 PAIR, WITH LEGS, 5 PAIR CONNECTOR BLOCK		
0 PLC ± -	1 PLC ± -	PRODUCT SPEC		
2 PLC ± -	3 PLC ± -	APPLICATION SPEC		
4 PLC ± -	ANGLES ± -	SIZE A1 00779 C=569434		
MATERIAL	FINISH	WEIGHT	SCALE 1:1	RESTRICTED TO
			SHEET 1 OF 1	REV B