

REV	MCO	DWN	DATE
B	20271165	RSG	01-SEP-09
C	40018217MCO	EAAE	21-NOV-14

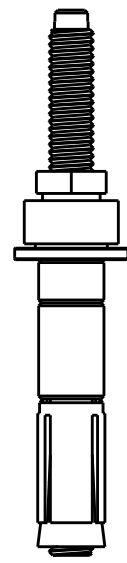

ANCHOR BOLT LOADED ON RACK
SHOWN ONLY REFERENCE

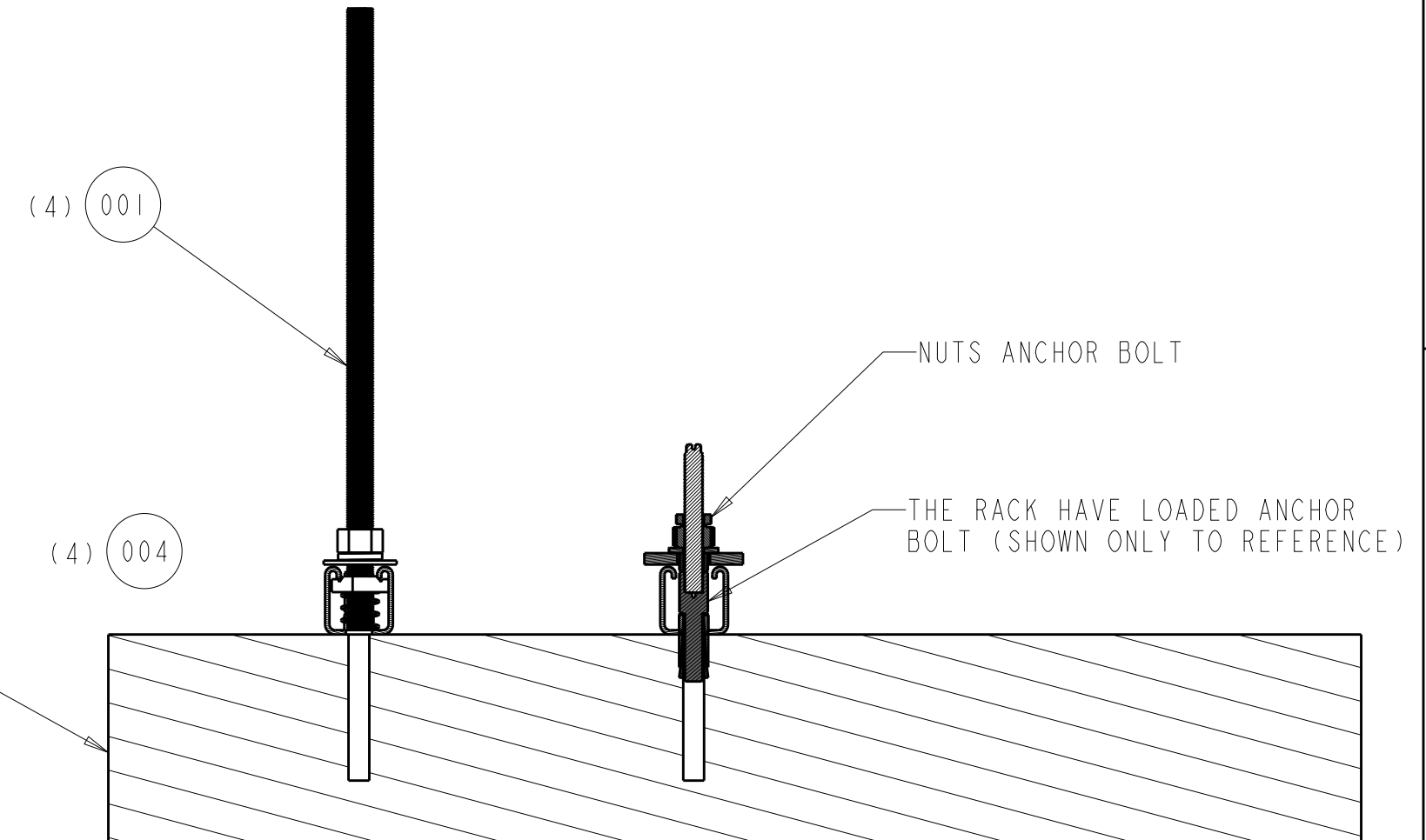

SECTION A-A
SCALE 0.250

CONCRETE FLOOR ANCHOR
DETAIL TYP (4) PLACES

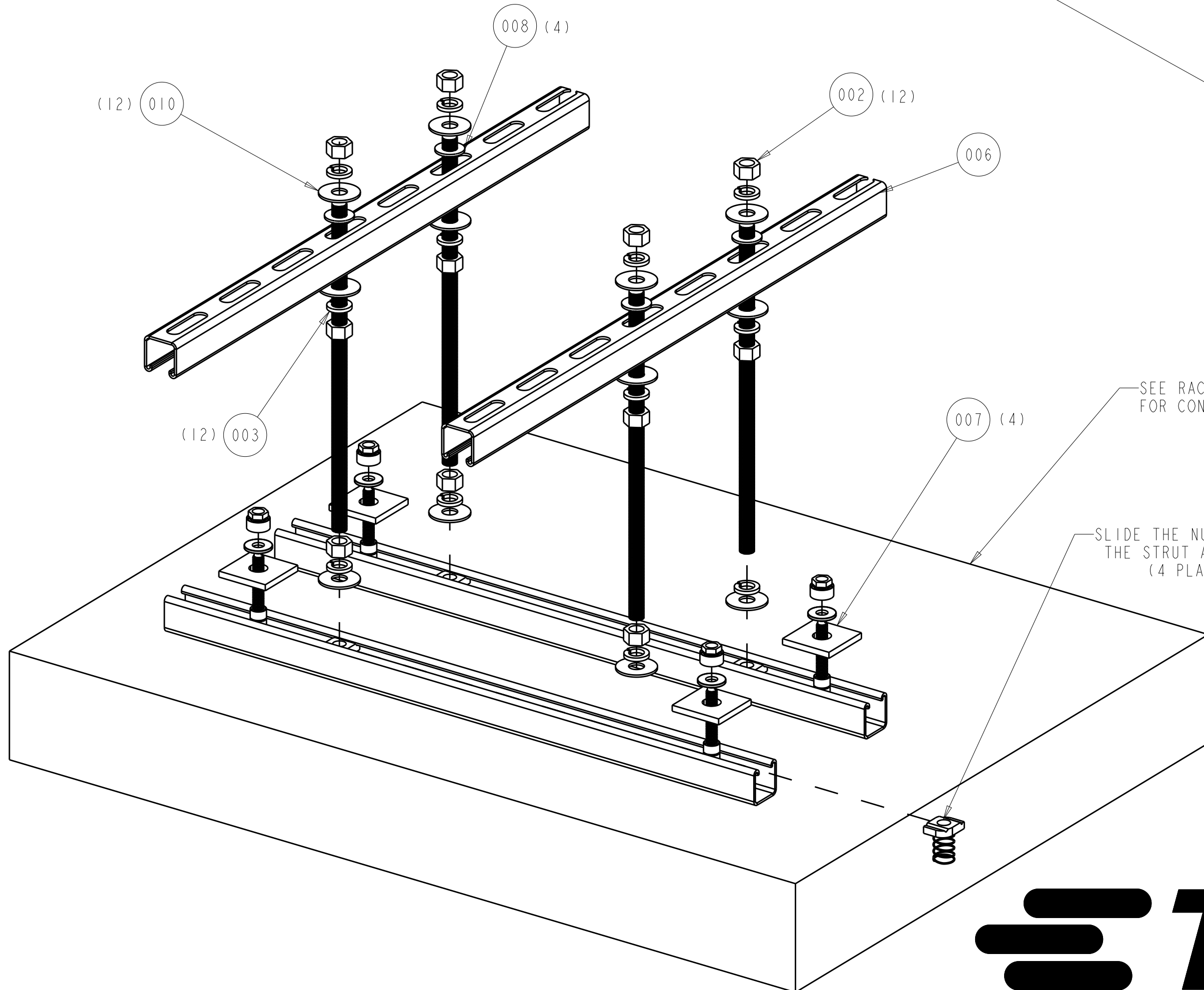

CONCRETE FLOOR REFERENCE

SEE RACK INSTALLATION DRAWING (ADCP-90-273)
FOR CONCRETE FLOOR HOLE DIMENSION

SLIDE THE NUT INSIDE
THE STRUT AS SHOWN.
(4 PLACES)

PART LIST

ITEM	DESCRIPTION	QTY
001	THREADED ROD, 5/8-11X30	4
002	NUT HEX 5/8-11 STL YZC	12
003	WASHER LOCK SPL .625"	12
004	NUT W/SPRING FOR UNISTRUT	4
006	STRUT (1-5/8) 1.62 X 1.62 X 10 FT SLOTTED	1
007	WASHER SQUARE M18, 60 MM SQ, 7MM THICK	4
008	WASHER, SHOULDER, NYLON	4
010	FLAT WASHER 5/8	12



INFORMATION ON THIS DOCUMENT IS
PROPRIETARY TO TE CONNECTIVITY AND
SHALL NOT BE USED, COPIED, REPRODUCED OR
DISCLOSED IN WHOLE OR IN PART WITHOUT
WRITTEN CONSENT OF TE CONNECTIVITY.

ALL DIMS AND TOLERANCES .XX:±xx
ARE INCHES UNLESS .XXX:±xxx
OTHERWISE SPECIFIED ANGULAR:±N/A

DO NOT SCALE DRAWING

ENGR: MARCELO RUIZ
DWN: SANTANA LOPEZ

TITLE INSTALATION DRAWING KIT
FDf MTG RAISED
FLOOR 5/8

DRAWING NUMBER 1423234_ADC

SHT. 1 OF 1

DIMENSIONS IN INCHES
THIRD ANGLE PROJECTION