

REV	MCO	DWN	DATE
C	20246327	AED	15-AUG-08
D	20265718	GCC	16-JUN-09

ISLAND WITH CAP

12" TRUMPET FLARE

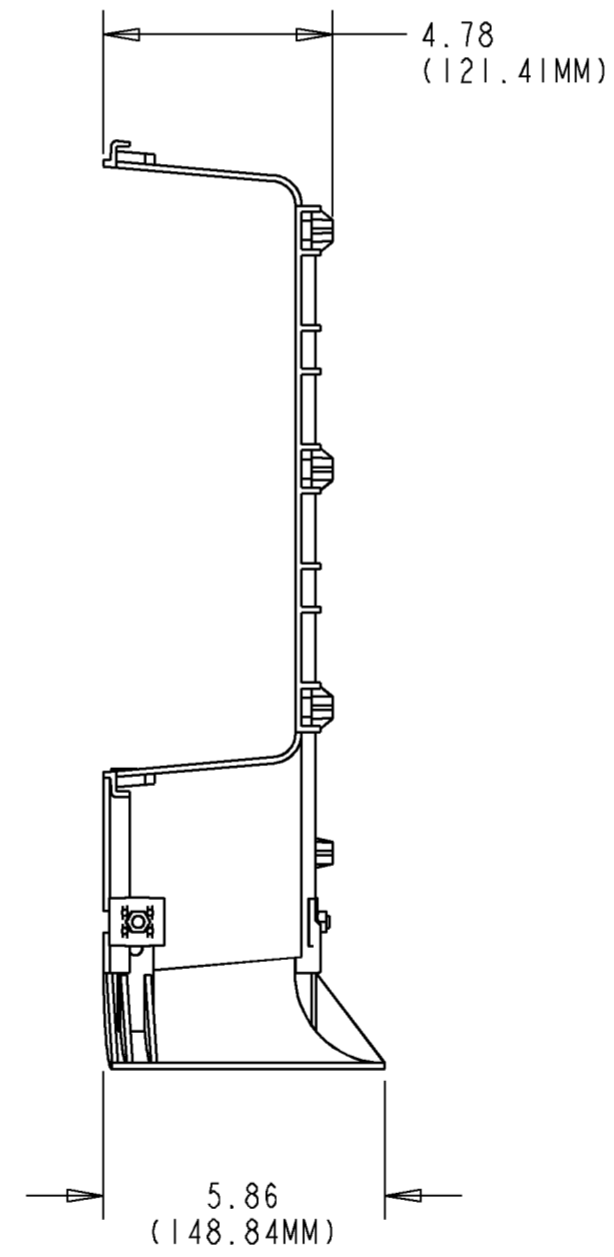
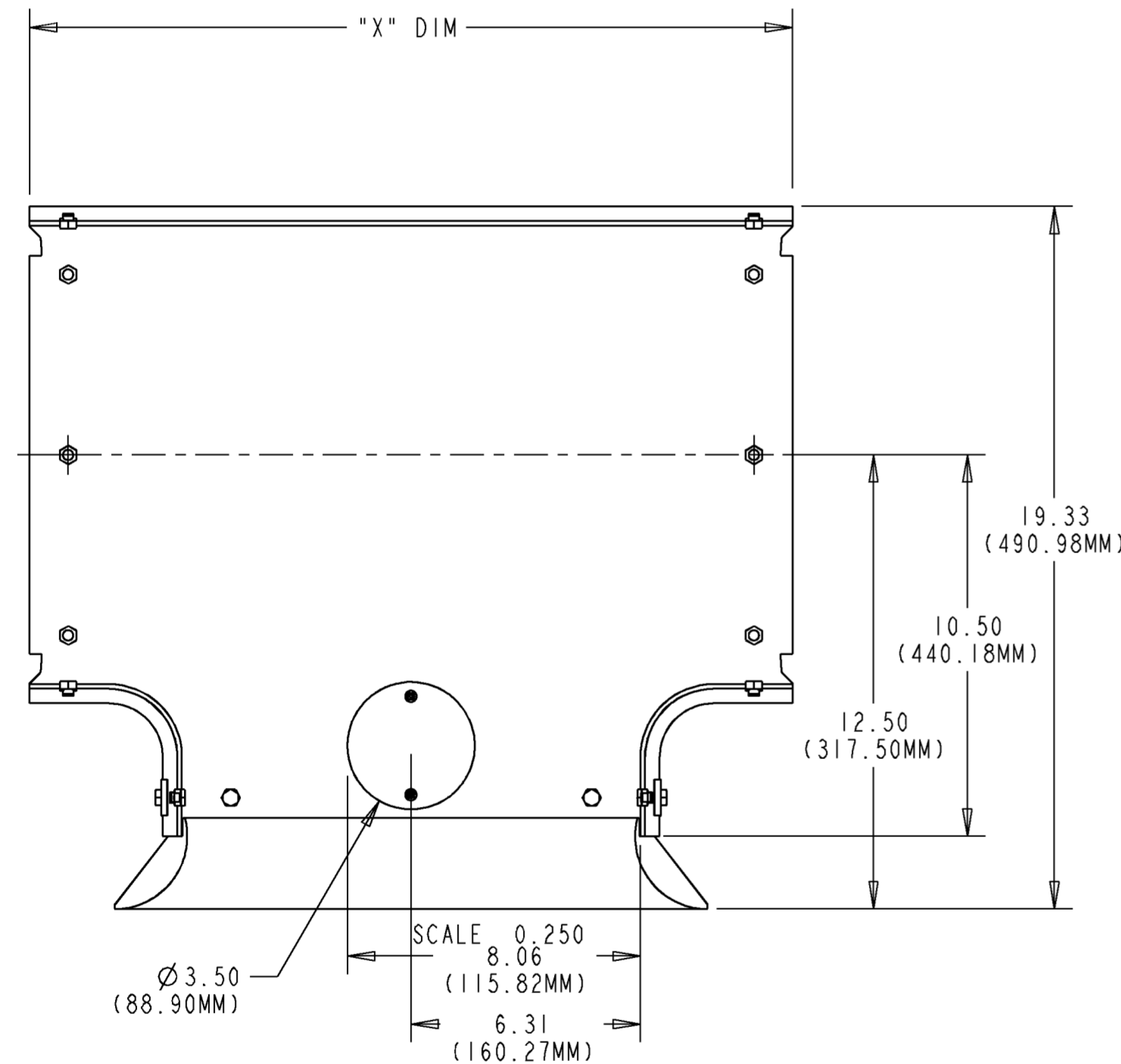

SUPPORT BRACKET MOUNTING BOSS (9)
8

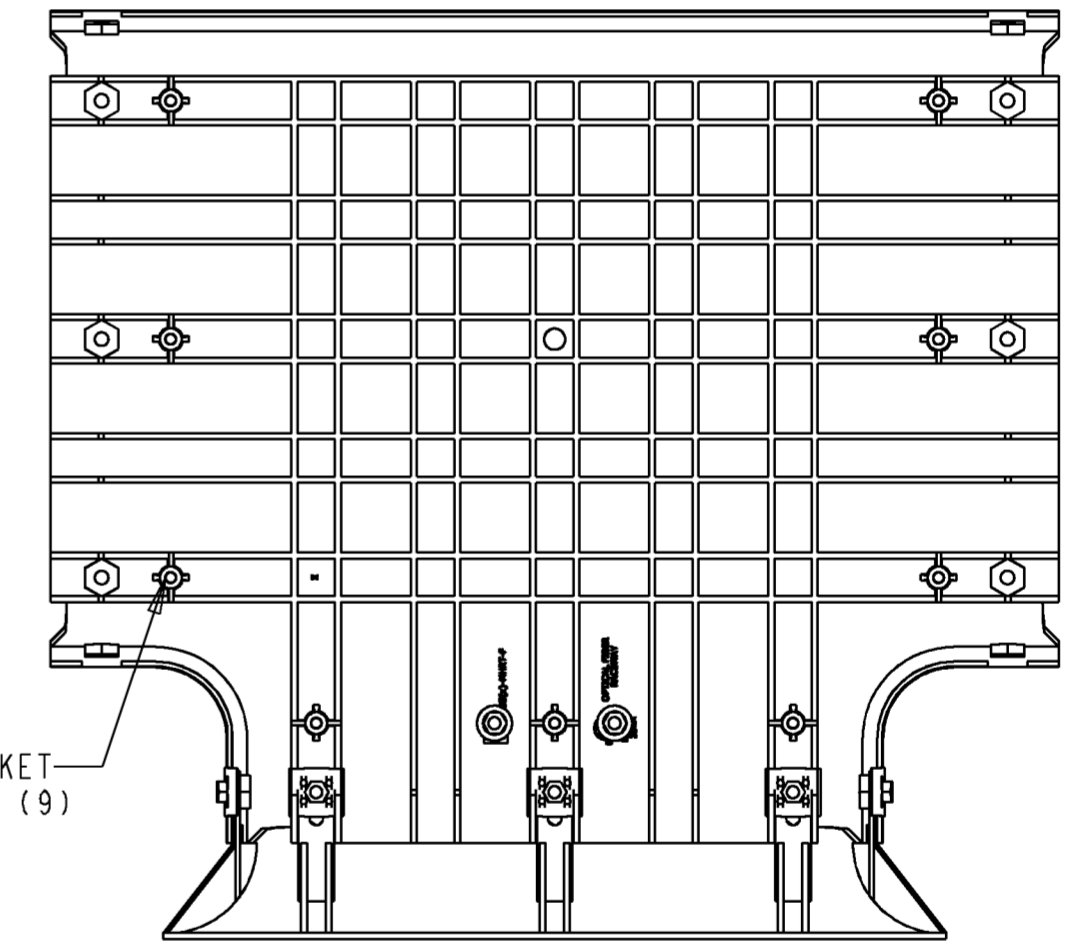

FGSB-ISLAND-F-513	20.20" / 513MM	BLACK
FGSB-ISLAND-F	20.99" / 533MM	BLACK
FGSO-ISLAND-F	20.99" / 533MM	ORANGE
FGS-ISLAND-F	20.99" / 533MM	YELLOW
FGS-ISLAND-F-513	20.20" / 513MM	YELLOW
CATALOG NUMBER	"X" WIDTH REF	COLOR

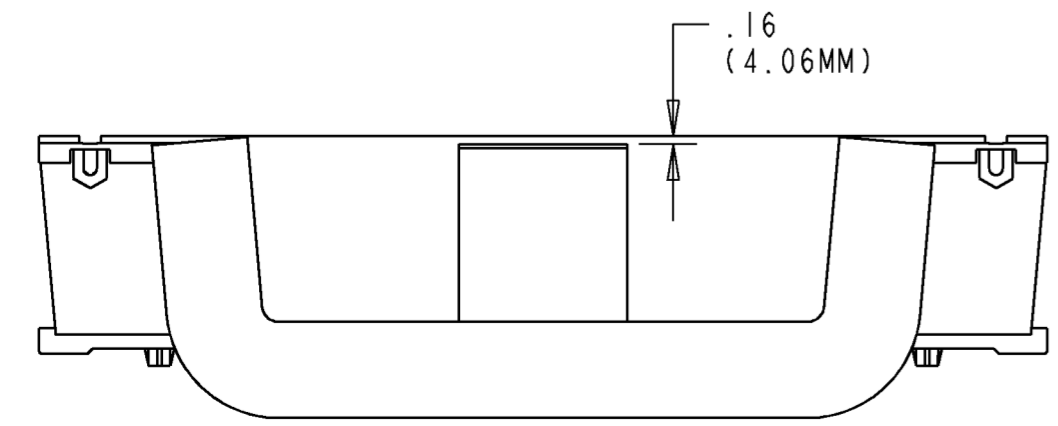

NOTES:

1. KIT INCLUDES THE FOLLOWING:
 - (1) 12"FGS TEE/ISLAND KIT ASSEMBLY, COMPRISED OF THE FOLLOWING:
 - (1) 12" TEE
 - (1) MOUNTED ISLAND
 - (1) ISLAND MOUNT BRACKET AND COVER
 - (1) ASSEMBLED TRUMPET FLARE
 - (1) ASSEMBLED MOUNTING BRACKETS



INFORMATION ON THIS DOCUMENT IS PROPRIETARY TO ADC AND SHALL NOT BE USED, COPIED, REPRODUCED OR DISCLOSED IN WHOLE OR IN PART WITHOUT WRITTEN CONSENT OF ADC.

TITLE ISLAND KIT, 12" FGS TEE INSTALLATION DRAWING

ALL DIMS AND TOLERANCES ARE INCHES UNLESS OTHERWISE SPECIFIED

DRAWING NUMBER 1250729

DO NOT SCALE DRAWING

ENGR: RYAN LINDQUIST
DWN: JUSTIN TRUESDELL

SHT. 1 OF 4

DIMENSIONS IN INCHES
THIRD ANGLE PROJECTION

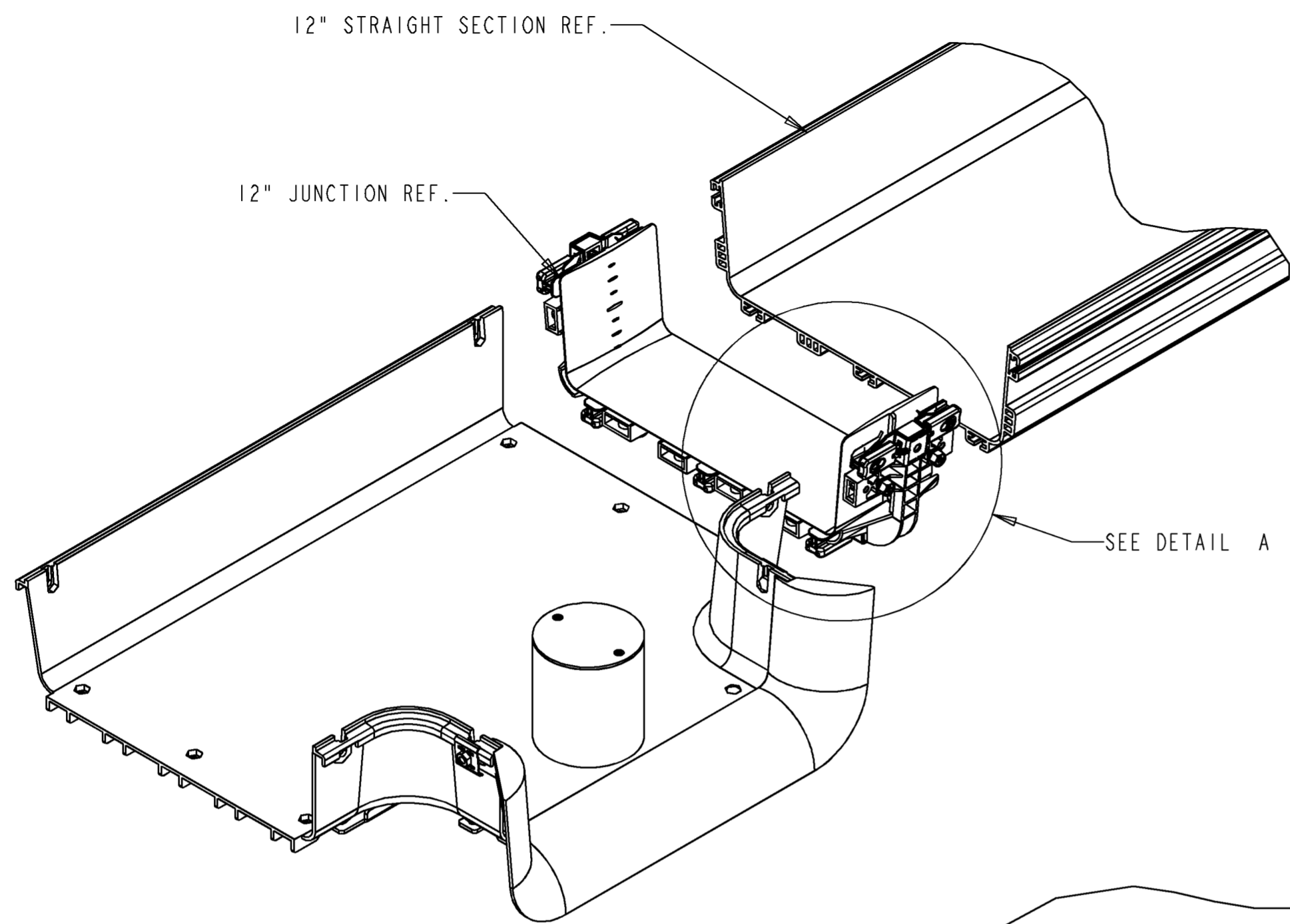
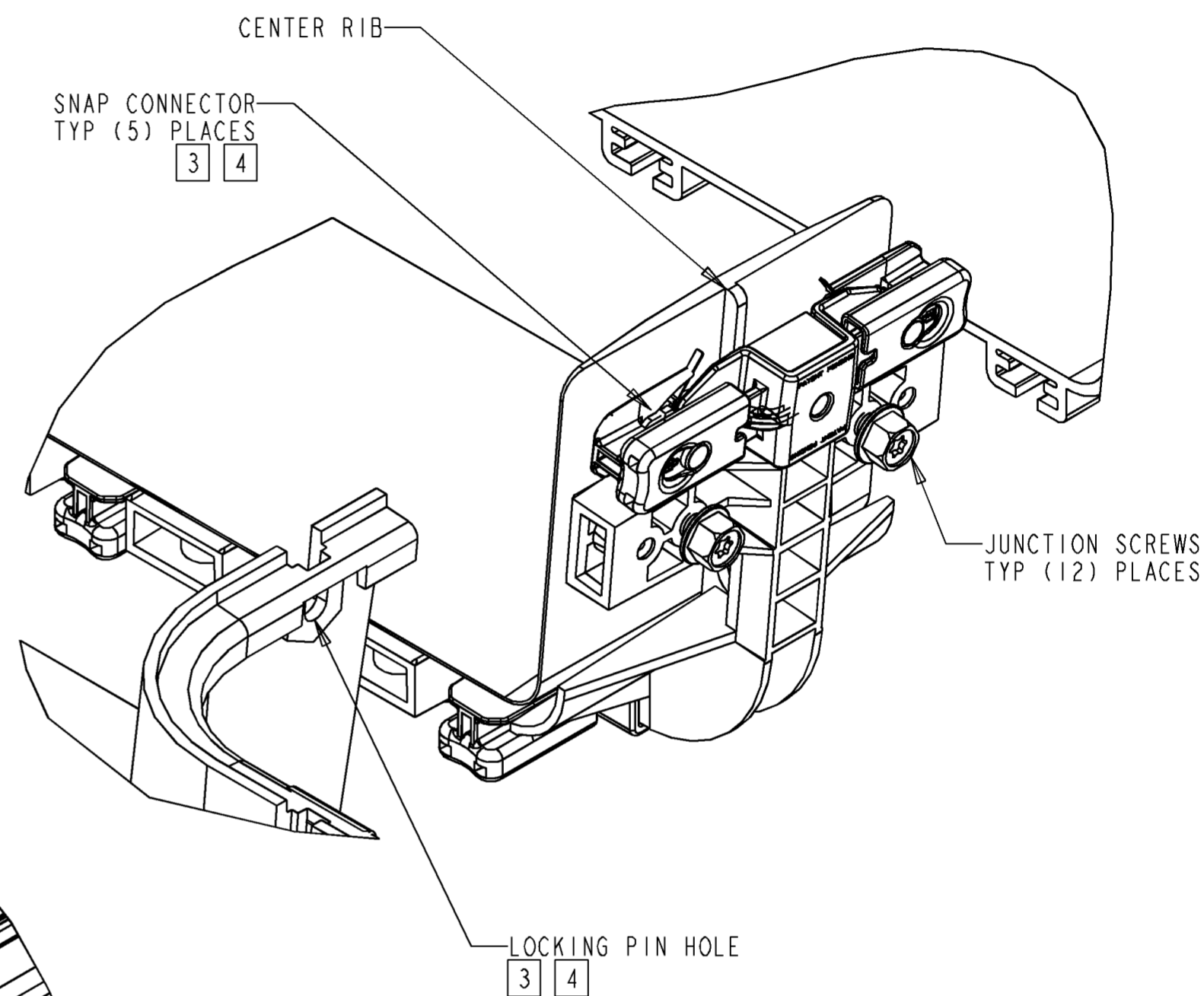

FIGURE 1



DETAIL A
SCALE 0.750

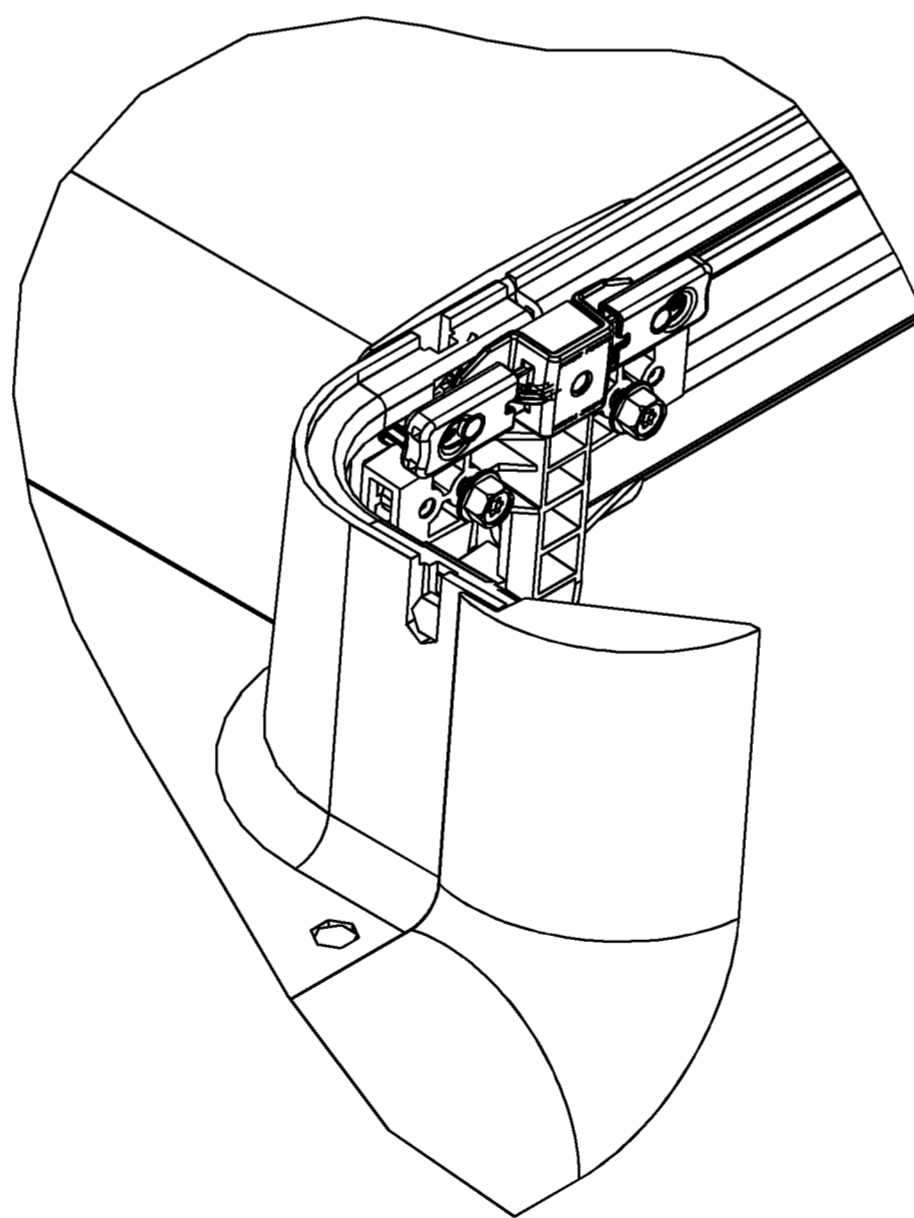

FIGURE 2
COMPLETED ASSEMBLY
SCALE 0.500

ASSEMBLY INSTRUCTIONS:

2. SLIDE ONE EXIT OF THE TEE KIT INTO JUNCTION UNTIL FIRMLY SEATED AGAINST THE CENTER RIB. (SEE FIGURE 2).
- 3 ENSURE LOCKING PINS ON SNAP CONNECTOR ARE ENGAGED IN HOLES IN TEE. (SEE FIGURE 2). ONLY APPLICABLE WITH ADC PART FGS-ISLAND-F.
- 4 SNAP CONNECTORS WILL NOT ENGAGE IN HOLES IN TEE FOR ADC PART FGS-ISLAND-F-513.
5. SLIDE THE 12" FIBERGUIDE STRAIGHT SECTION INTO THE JUNCTION UNTIL FIRMLY SEATED AGAINST THE CENTER RIB.
6. TIGHTEN THE (12) JUNCTION SCREWS SUCH THAT THE WASHER HEAD ON THE SCREW IS APPROXIMATELY 1/16" (1.6MM) FROM THE JUNCTION SUPPORT ARM. (SEE DETAIL A). AFTER ALL SCREWS HAVE BEEN TIGHTENED IN THIS MANNER, TIGHTEN ALL SCREWS UNTIL THE WASHER HEAD BOTTOMS OUT.
7. REPEAT ABOVE NOTES FOR THE OTHER EXIT OF THE TEE.



INFORMATION ON THIS DOCUMENT IS PROPRIETARY TO ADC AND SHALL NOT BE USED, COPIED, REPRODUCED OR DISCLOSED IN WHOLE OR IN PART WITHOUT WRITTEN CONSENT OF ADC.		TITLE ISLAND KIT, 12" FGS TEE INSTALLATION DRAWING	
ALL DIMS AND TOLERANCES ARE INCHES UNLESS OTHERWISE SPECIFIED	.XX:±N/A .XXX:±N/A ANGULAR:±N/A	C SIZE	DRAWING NUMBER 1250729
DO NOT SCALE DRAWING		ENGR: RYAN LINDQUIST DWN: JUSTIN TRUESDELL	D REV SHT. 2 OF 4

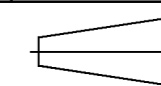
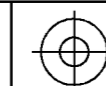

DIMENSIONS IN INCHES
THIRD ANGLE PROJECTION

A

B

C

D

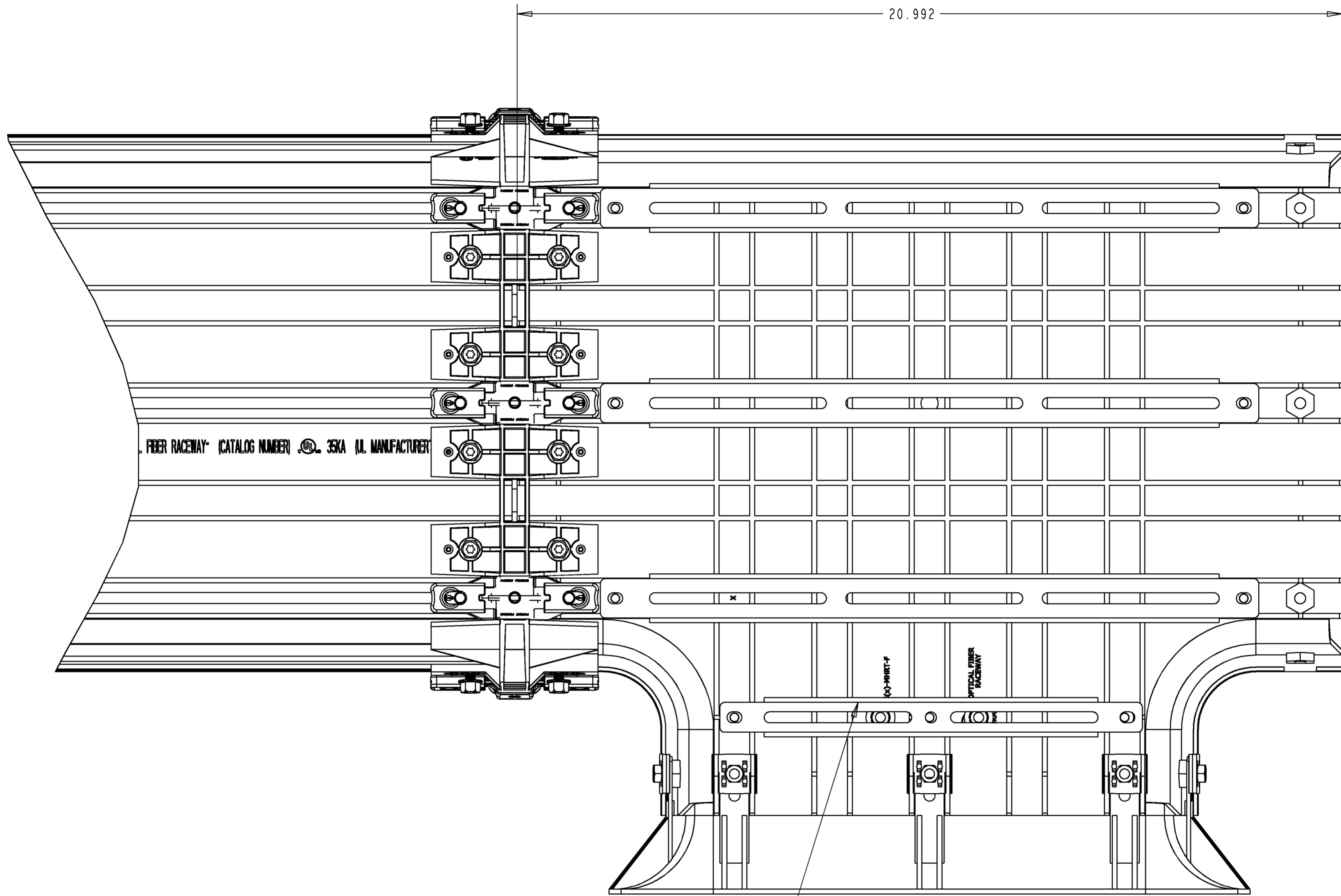

MOUNTING INSTRUCTIONS:

- 8 FOR ADC PART FGS-ISLAND-F, MOUNT BRACKET TO SUPPORT BRACKET MOUNTING BOSSES WITH BOSS SCREWS INCLUDED IN BRACKET KIT. (SEE SHEET 1 AND BRACKET KIT INSTALLATION DRAWING.)
- 9 FOR ADC PART FGS-ISLAND-F-513, MOUNT BRACKET TO VARIABLE SUPPORT MOUNTING BRACKETS WITH T-BOLTS INCLUDED IN BRACKET KIT. (SEE SHEET 3 AND BRACKET KIT INSTALLATION DRAWING.)

VARIABLE SUPPORT MOUNTING BRACKETS

9



INFORMATION ON THIS DOCUMENT IS PROPRIETARY TO ADC AND SHALL NOT BE USED, COPIED, REPRODUCED OR DISCLOSED IN WHOLE OR IN PART WITHOUT WRITTEN CONSENT OF ADC.

ALL DIMS AND TOLERANCES ARE INCHES UNLESS OTHERWISE SPECIFIED

.XX:±N/A
.XXX:±N/A
ANGULAR:±N/A

TITLE ISLAND KIT, 12" FGS TEE INSTALLATION DRAWING

DO NOT SCALE DRAWING

ENGR: RYAN LINDQUIST
DWN: JUSTIN TRUESDELL

C SIZE DRAWING NUMBER 1250729

D REV SHT. 3 OF 4

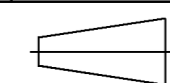

DIMENSIONS IN INCHES
THIRD ANGLE PROJECTION

A

B

C

A

B

C

D

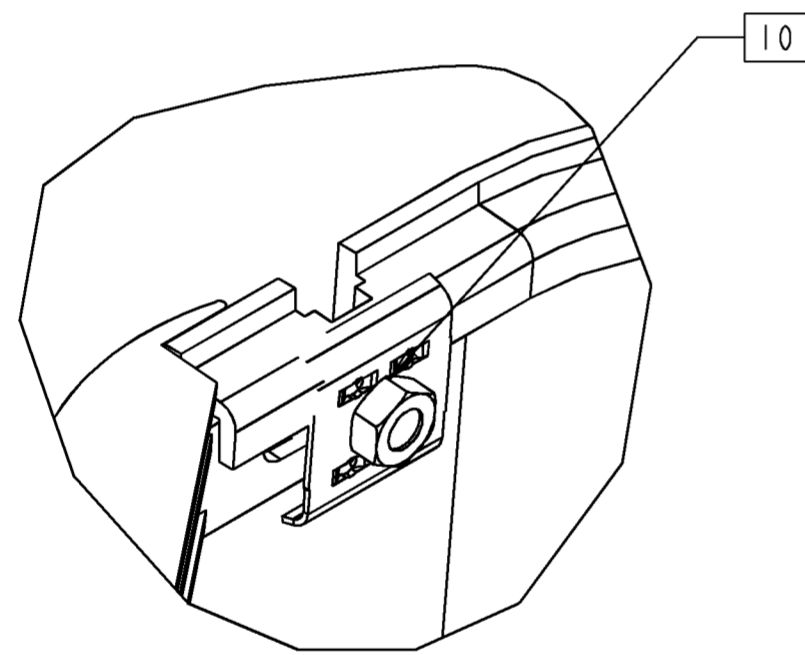
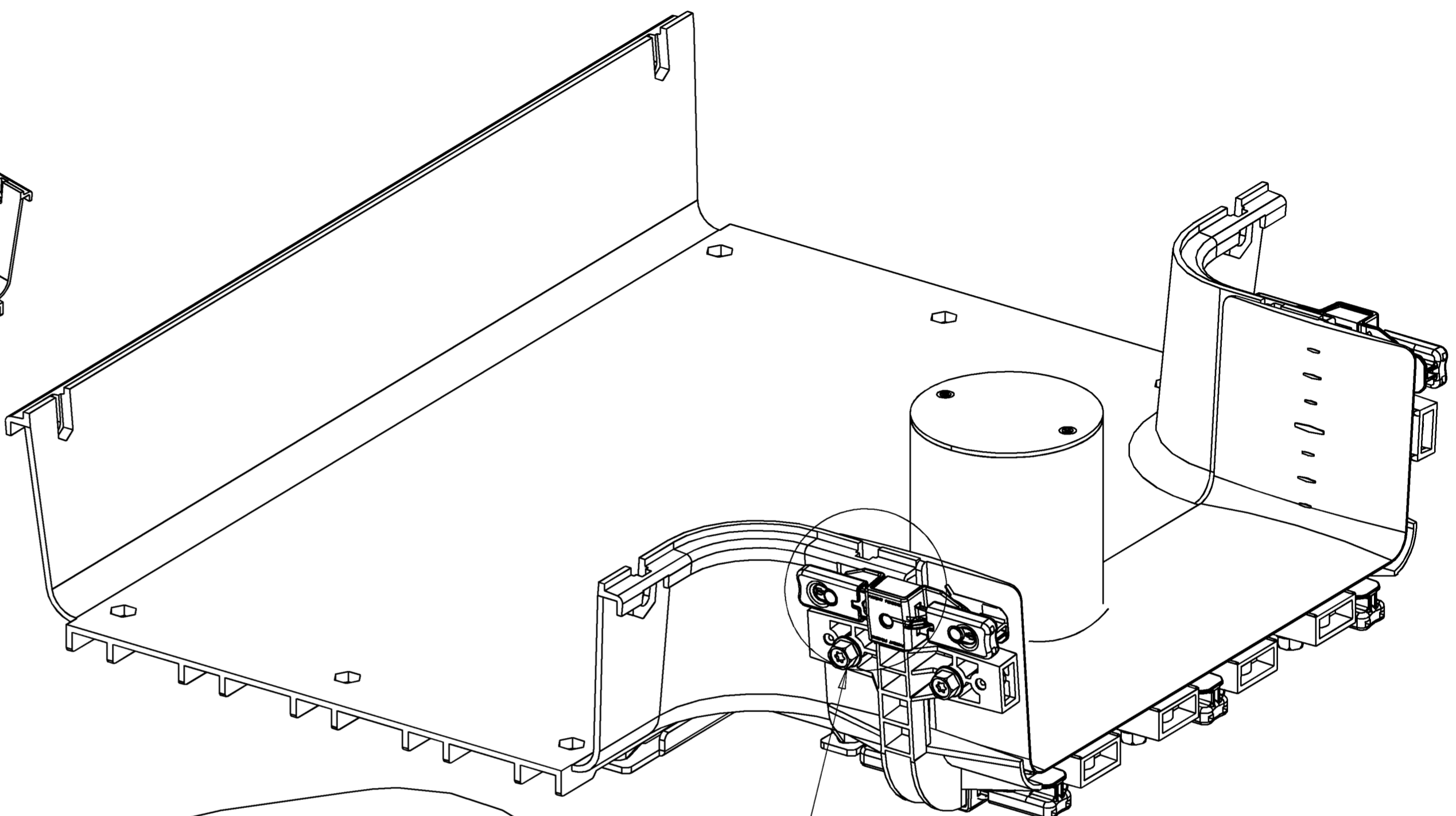
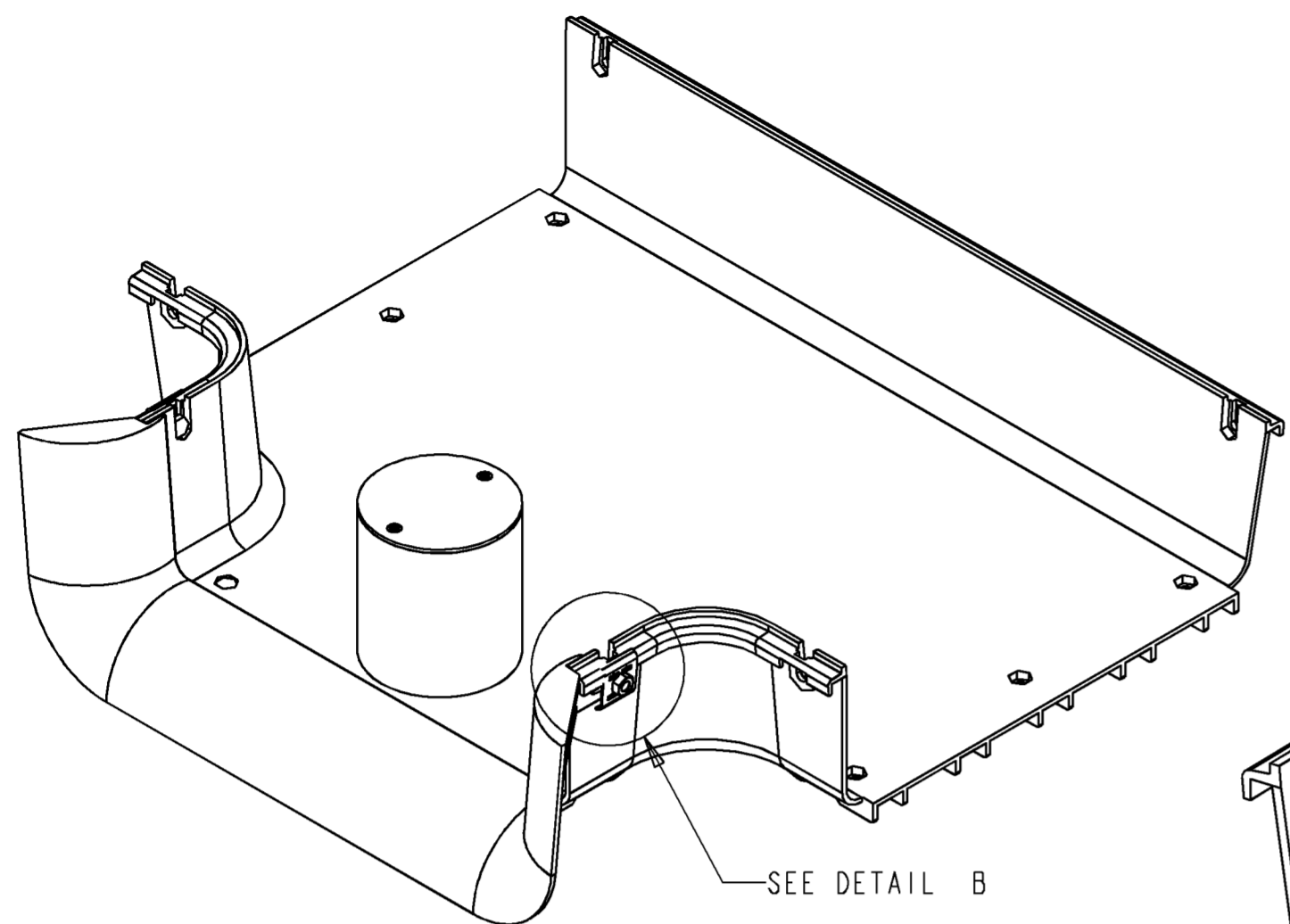

DETAIL B
SCALE 1.000

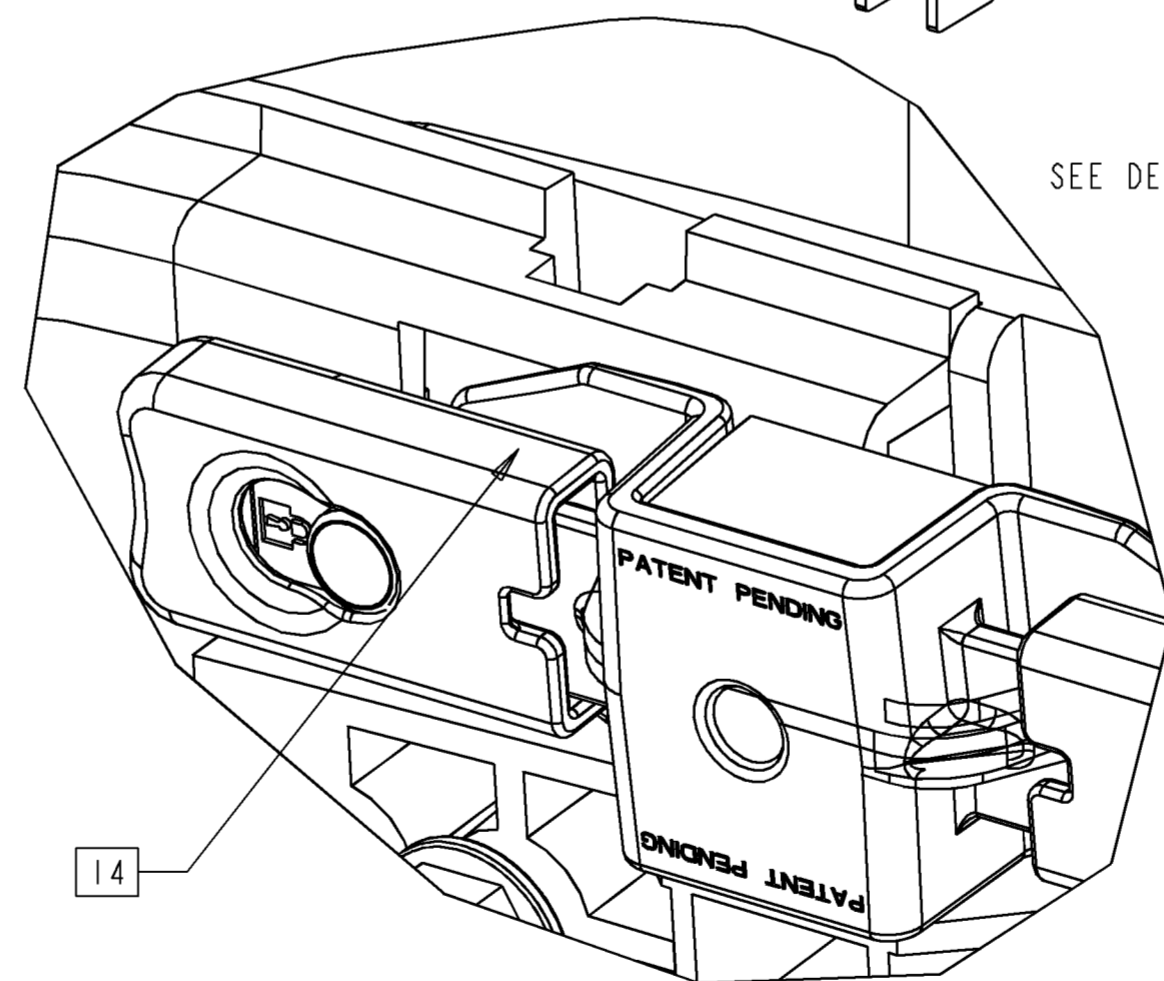

DETAIL C
SCALE 2.000

JUNCTION INSTALLATION (OPTIONAL):

- 10. REMOVE HEX NUTS, RETAINING WASHERS, AND HEX BOLTS SECURING TRUMPET FLARE TO TEE.
- 11. REMOVE TRUMPET FLARE.
- 12. LOOSEN HEX NUTS SECURING ISLAND TO TEE FITTING.
- 13. SLIDE FGS JUNCTION (FGS-JUNC-F) ONTO EXIT OF TEE FITTING AND UNDER ISLAND ASSEMBLY UNTIL FIRMLY SEATED AGAINST THE CENTER RIB.
- 14. ENSURE LOCKING PINS ON SNAP CONNECTOR ARE ENGAGED IN HOLES IN TEE.
- 15. TIGHTEN THE JUNCTION SCREWS PER NOTE 6.
- 16. TIGHTEN HEX NUTS SECURING ISLAND TO TEE FITTING COMPLETELY.



INFORMATION ON THIS DOCUMENT IS PROPRIETARY TO ADC AND SHALL NOT BE USED, COPIED, REPRODUCED OR DISCLOSED IN WHOLE OR IN PART WITHOUT WRITTEN CONSENT OF ADC.		TITLE ISLAND KIT, 12" FGS TEE INSTALLATION DRAWING	
ALL DIMS AND TOLERANCES ARE INCHES UNLESS OTHERWISE SPECIFIED	.XX:±N/A .XXX:±N/A ANGULAR:±N/A	C SIZE	DRAWING NUMBER 1250729
DO NOT SCALE DRAWING	ENGR: RYAN LINDQUIST DWN: JUSTIN TRUESDELL	SHT. 4 OF 4	

DIMENSIONS IN INCHES
THIRD ANGLE PROJECTION