

\varnothing 0.30(0.012)	M	T	X	S	Y	S
\varnothing 0.15(0.006)	M	T				

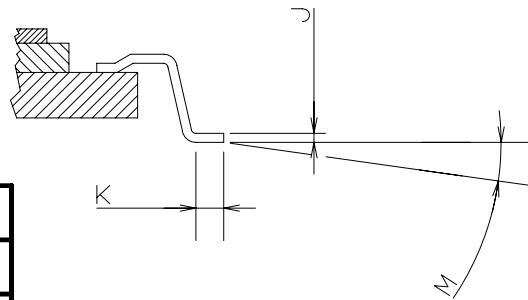

CASE NO.	831B-01
STANDARD	MOTOROLA STANDARD
REFERENCE	-
TITLE	132 LD CQFP

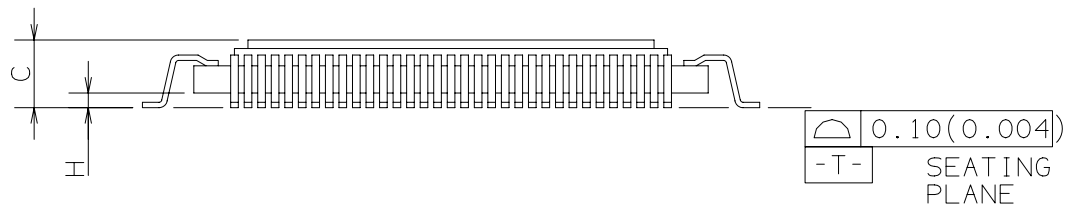

NOTES:

1. DIMENSIONING AND TOLERANCING PER ANSI Y14.5M, 1982.
2. CONTROLLING DIMENSION: INCH.
3. DATUMS X AND Y TO BE DETERMINED WHERE CENTER LEADS EXIT THE BODY.

DIM	MILLIMETERS		INCHES		DIM	MILLIMETERS		INCHES	
	MIN	MAX	MIN	MAX		MIN	MAX	MIN	MAX
A	23.88	24.38	0.940	0.960					
B	23.88	24.38	0.940	0.960					
C	---	3.17	---	0.125					
D	0.21	0.35	0.008	0.014					
G	0.64 BSC		0.025 BSC						
H	0.46	0.88	0.018	0.035					
J	0.13	0.25	0.005	0.010					
K	0.61	1.01	0.024	0.040					
L	20.32 BSC		0.800 BSC						
M	0°	8°	0°	8°					
S	28.78	29.13	1.133	1.147					
V	28.78	29.13	1.133	1.147					
CASE NO.		831B-01							
STANDARD		MOTOROLA STANDARD							
REFERENCE		-							
TITLE		132 LD CQFP							
									SHEET 2 OF 2