

THIS DRAWING IS UNPUBLISHED.

RELEASED FOR PUBLICATION

ALL RIGHTS RESERVED.

© COPYRIGHT - By -

REVISIONS

P	LTR	DESCRIPTION	DATE	DWN	APVD
2		STRIKE THROUGH OBS PARTS. ECR-16-009538	07JUL2016	AFK	LS

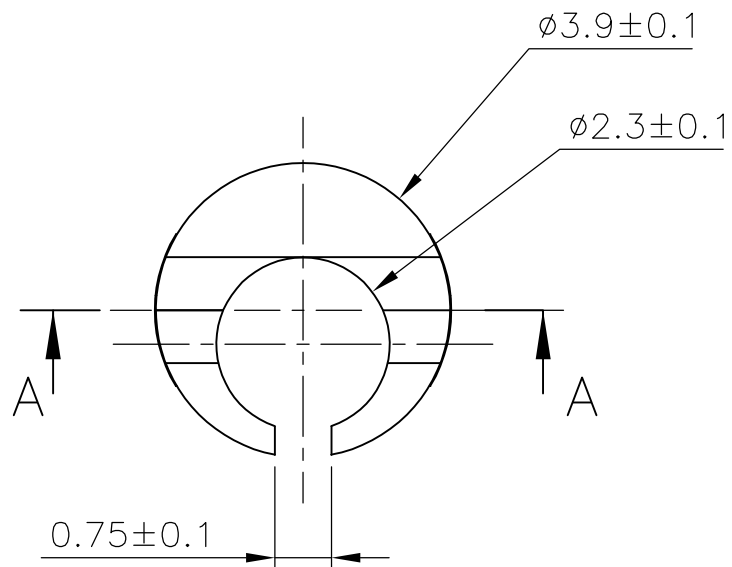
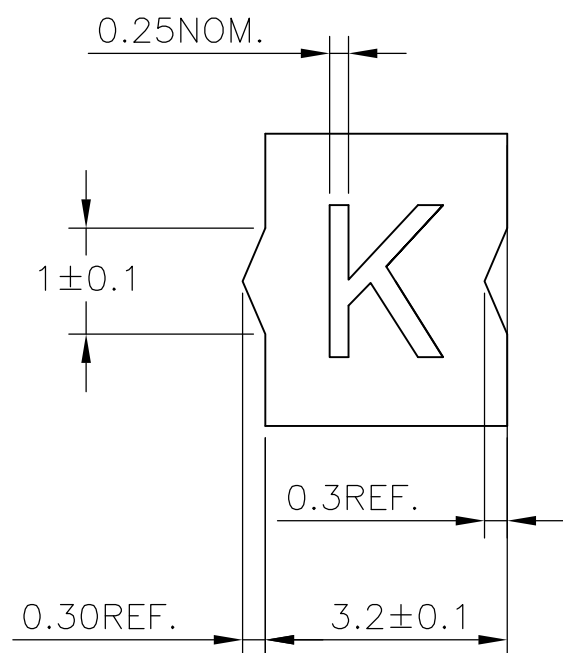

A-A

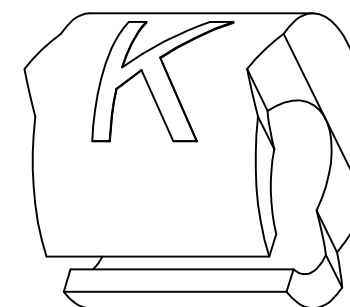
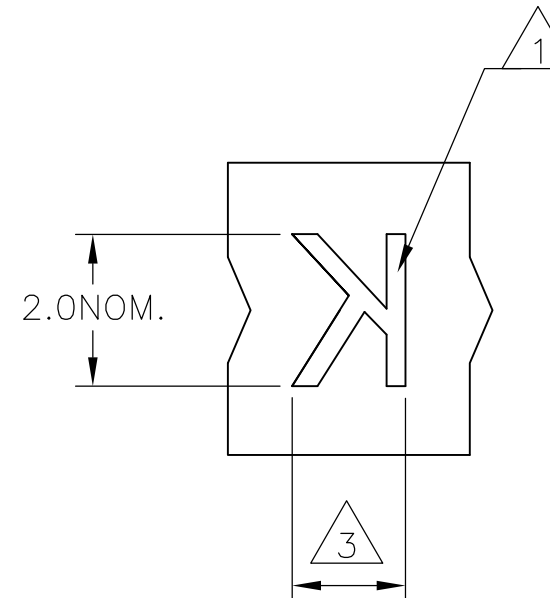
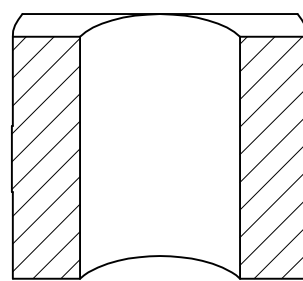

NOTES:

- 1 FOR PART NUMBERS SEE SHEET 3 OF 3.
- 2 MARK SHOULD BE CENTRALLY POSITIONED ±0.1 mm
- 3 WIDTH OF MARK DEPENDS ON CHARACTER PRINTED

THIS DRAWING IS A CONTROLLED DOCUMENT.		DWN RAGHAVENDRA K 23MAR2013	TE Connectivity														
DIMENSIONS: mm		CHK KEAN ALAN 23MAR2013															
TOLERANCES UNLESS OTHERWISE SPECIFIED:		APVD MARIO APPELLO 23MAR2013	NAME SNAP-ON MARKER STB/STD05 WITH APPLICATOR														
<table border="0"> <tr><td>0 PLC</td><td>± -</td></tr> <tr><td>1 PLC</td><td>± -</td></tr> <tr><td>2 PLC</td><td>± -</td></tr> <tr><td>3 PLC</td><td>± -</td></tr> <tr><td>4 PLC</td><td>± -</td></tr> <tr><td>ANGLES</td><td>± -</td></tr> </table>		0 PLC	± -	1 PLC	± -	2 PLC	± -	3 PLC	± -	4 PLC	± -	ANGLES	± -	PRODUCT SPEC -	-		
0 PLC	± -																
1 PLC	± -																
2 PLC	± -																
3 PLC	± -																
4 PLC	± -																
ANGLES	± -																
MATERIAL -		FINISH -	APPLICATION SPEC -	SIZE A3	CAGE CODE 00779	DRAWING NO C-6-1768043-2	RESTRICTED TO -										
CUSTOMER DRAWING			WEIGHT 0	SCALE NTS	SHEET 1 OF 3	REV 2											

THIS DRAWING IS UNPUBLISHED. RELEASED FOR PUBLICATION
 © COPYRIGHT - By - ALL RIGHTS RESERVED.

REVISIONS					
P	LTR	DESCRIPTION	DATE	DWN	APVD
-	-	SEE SHEET 1	-	-	-

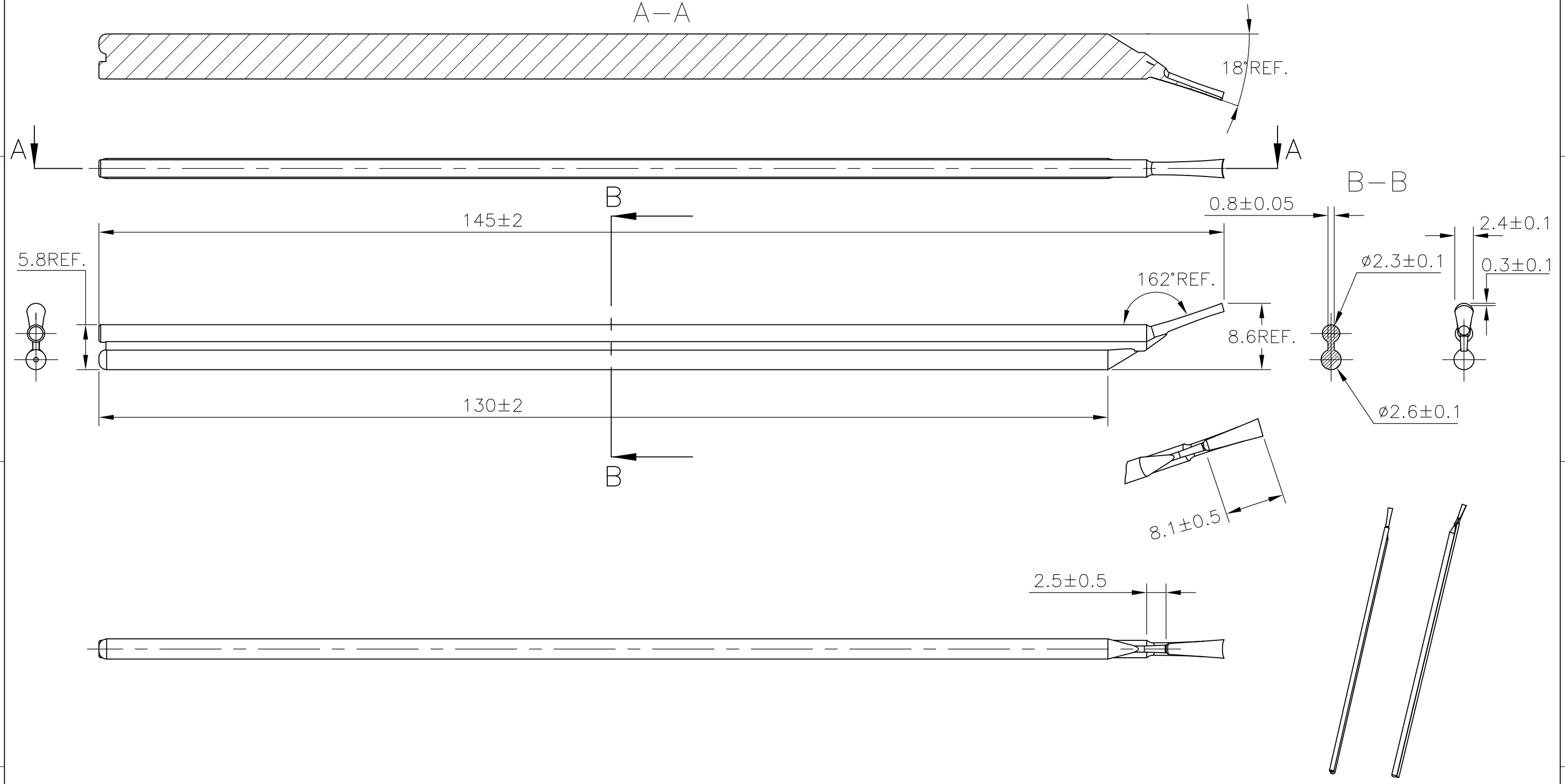

THIS DRAWING IS A CONTROLLED DOCUMENT.		DWN RAGHAVENDRA K 23MAR2013	 TE Connectivity				
DIMENSIONS: mm		CHK KEAN ALAN 23MAR2013					
TOLERANCES UNLESS OTHERWISE SPECIFIED:		APVD MARIO APPELLO 23MAR2013	NAME SNAP-ON MARKER STB/STD05 WITH APPLICATOR				
0 PLC ± - 1 PLC ± - 2 PLC ± - 3 PLC ± - 4 PLC ± - ANGLES ± -		PRODUCT SPEC -	APPLICATION SPEC -				
MATERIAL -		FINISH -	WEIGHT -	SIZE A3	CAGE CODE 00779	DRAWING NO C-6-1768043-2	RESTRICTED TO -
CUSTOMER DRAWING			SCALE NTS	SHEET 2 OF 3	REV 2		

THIS DRAWING IS UNPUBLISHED.

RELEASED FOR PUBLICATION

REVISIONS

© COPYRIGHT - By -

ALL RIGHTS RESERVED.

P	LTR	DESCRIPTION	DATE	DWN	APVD
-	-	SEE SHEET 1	-	-	-

DESCRIPTION	PART NO.
STB05-1-1	1-1768038-8
STB05-2-2	1-1768038-9
STB05-5-5	2-1768038-1
STB05-6-6	2-1768038-2
STB05-BLANK-1	2-1768038-6
STB05-BLANK-5	2-1768038-9
STB05-BLANK-6	3-1768038-0
STD05W-0	7-1768042-3
STD05W-1	7-1768042-4
STD05W-2	7-1768042-5
STD05W-3	7-1768042-6
STD05W-4	7-1768042-7
STD05W-5	7-1768042-8
STD05W-6	7-1768042-9
STD05W-7	8-1768042-0
STD05W-8	8-1768042-1
STD05W-9	8-1768042-2
STD05W-A	8-1768042-3
STD05W-A-LC	8-1768042-5
STD05W-B	8-1768042-6
STD05W-BLANK	8-1768042-7
STD05W-B-LC	8-1768042-8
STD05W-C	8-1768042-9
STD05W-COLON	9-1768042-0
STD05W-D	9-1768042-1
STD05W-D-LC	9-1768042-2
STD05W-DOT	9-1768042-3
STD05W-E	9-1768042-4
STD05W-E-LC	9-1768042-6
STD05W-F	9-1768042-7
STD05W-F-LC	9-1768042-8
STD05W-G	9-1768042-9

4

4

4

4

DESCRIPTION	PART NO.
STD05W-G-LC	1-1768043-1
STD05W-H	1768043-2
STD05W-H-LC	1-1768043-3
STD05W-I	1768043-4
STD05W-J	1768043-5
STD05W-K	1768043-6
STD05W-K-LC	1-1768043-7
STD05W-L	1768043-8
STD05W-L-LC	1-1768043-9
STD05W-M	1-1768043-0
STD05W-MINUS	1-1768043-1
STD05W-N	1-1768043-3
STD05W-P	1-1768043-5
STD05W-PLUS	1-1768043-6
STD05W-Q	1-1768043-7
STD05W-R	1-1768043-8
STD05W-S	2-1768043-0
STD05W-SLASH	2-1768043-1
STD05W-T	2-1768043-2
STD05W-U	2-1768043-3
STD05W-V	2-1768043-5
STD05W-W	2-1768043-6
STD05W-X	2-1768043-7
STD05W-Y	2-1768043-8
STD05W-Z	2-1768043-9
STD05Y-0	3-1768043-0
STD05Y-1	3-1768043-1
STD05Y-2	3-1768043-2

DESCRIPTION	PART NO.
STD05Y-3	3-1768043-3
STD05Y-4	3-1768043-4
STD05Y-5	3-1768043-5
STD05Y-6	3-1768043-6
STD05Y-7	3-1768043-7
STD05Y-8	3-1768043-8
STD05Y-9	3-1768043-9
STD05Y-A	4-1768043-0
STD05Y-B	4-1768043-3
STD05Y-BLANK	4-1768043-4
STD05Y-C	4-1768043-6
STD05Y-D	4-1768043-8
STD05Y-DOT	5-1768043-0
STD05Y-E	5-1768043-1
STD05Y-EARTH	5-1768043-2
STD05Y-F	5-1768043-4
STD05Y-G	5-1768043-6
STD05Y-H	5-1768043-8
STD05Y-I	6-1768043-0
STD05Y-J	6-1768043-1
STD05Y-K	6-1768043-2
STD05Y-L	6-1768043-4
STD05Y-M	6-1768043-6
STD05Y-MINUS	6-1768043-7
STD05Y-N	6-1768043-9

DESCRIPTION	PART NO.
STD05Y-P	7-1768043-1
STD05Y-PLUS	7-1768043-2
STD05Y-Q	7-1768043-3
STD05Y-R	7-1768043-4
STD05Y-S	7-1768043-6
STD05Y-SLASH	7-1768043-7
STD05Y-T	7-1768043-8
STD05Y-U	7-1768043-9
STD05Y-V	8-1768043-0
STD05Y-W	8-1768043-1
STD05Y-X	8-1768043-2
STD05Y-Y	8-1768043-3
STD05Y-Z	8-1768043-4

4 OBSOLETE PART

4

4

4

4

4

THIS DRAWING IS A CONTROLLED DOCUMENT.		DWN 23MAR2013 RAGHAVENDRA K	 TE Connectivity
		CHK 23MAR2013 KEAN ALAN	
DIMENSIONS: mm		APVD 23MAR2013 MARIO APPELLO	NAME SNAP-ON MARKER STB/STD05 WITH APPLICATOR
TOLERANCES UNLESS OTHERWISE SPECIFIED:		PRODUCT SPEC	
0 PLC ± -		APPLICATION SPEC	
1 PLC ± -		WEIGHT	SIZE CAGE CODE DRAWING NO RESTRICTED TO
2 PLC ± -			A3 00779 C-6-1768043-2
3 PLC ± -			SCALE NTS SHEET 3 OF 3 REV 2
4 PLC ± -			
ANGLES ± -			
FINISH			
MATERIAL			
		CUSTOMER DRAWING	