

REVISIONS					
P	LTR	DESCRIPTION	DATE	DN	APVD
C3		REVISED PER ECO-16-004800	08SEP2016	NK	MZ

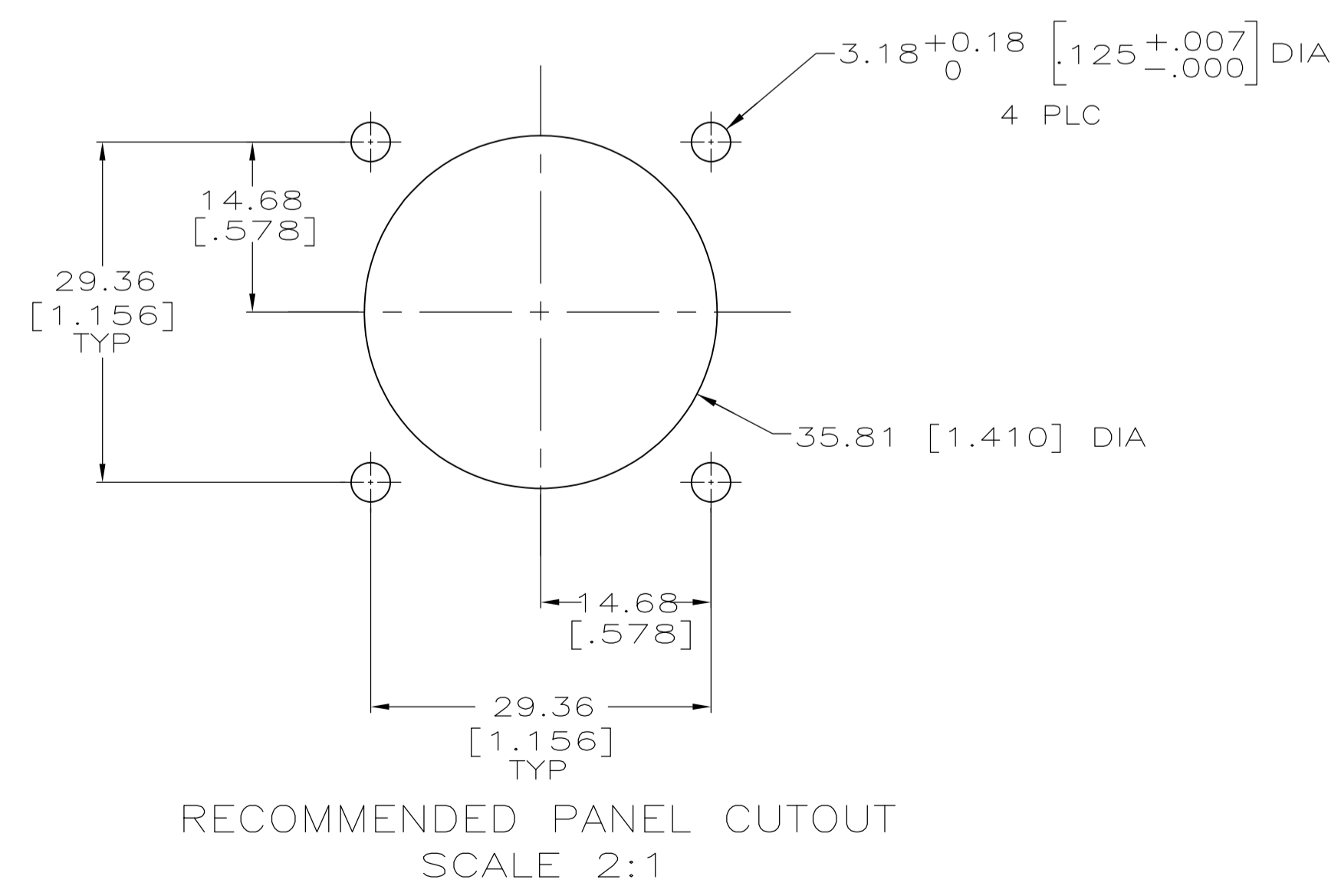
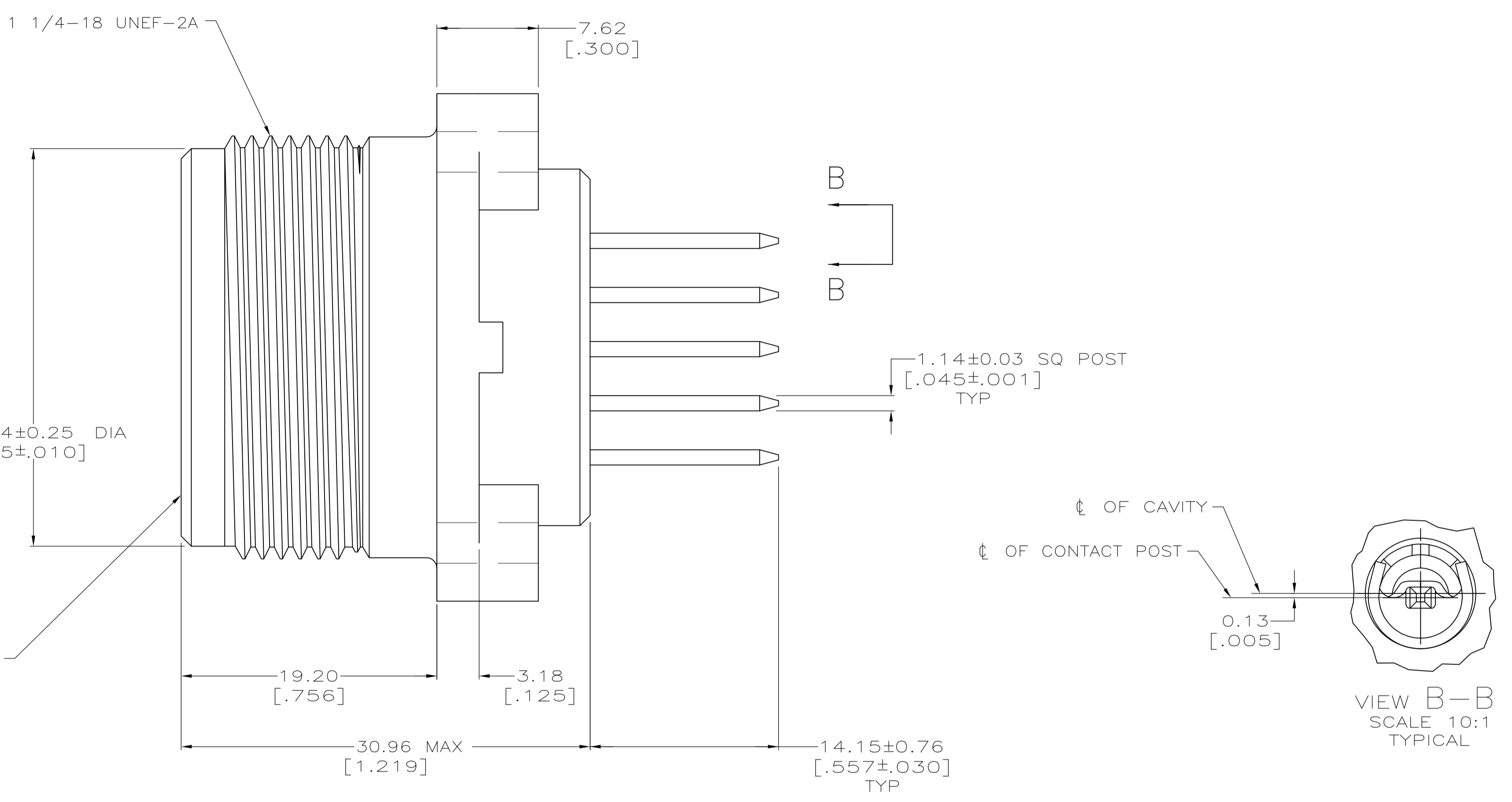
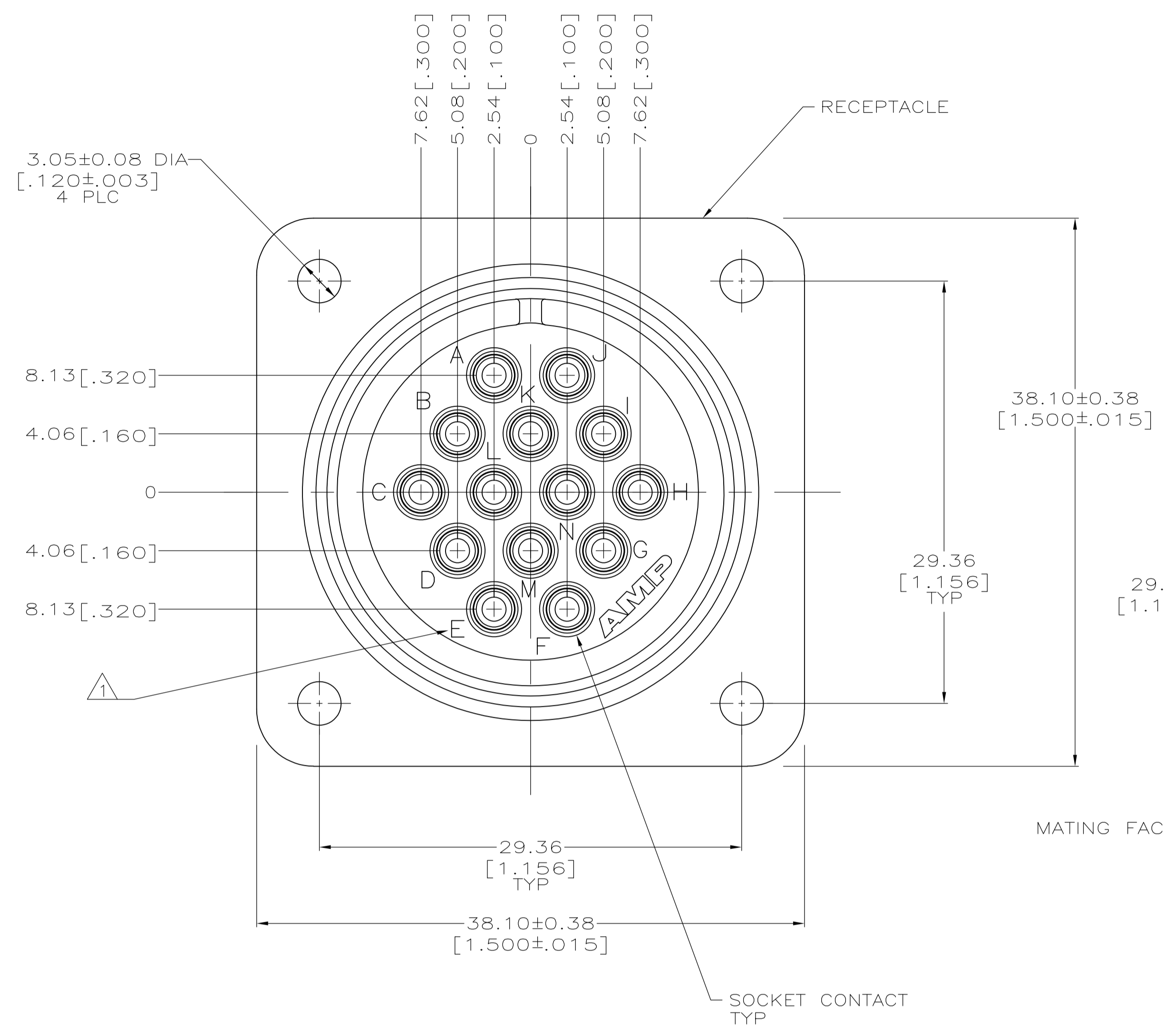

- △ CAVITY IDENTIFICATION CHARACTERS ON FRONT AND REAR FACE.
- △ RECEPTACLE: NYLON, UL 94V-0 RATED, BLACK.  
CONTACT AND POST: BRASS.  
SPRING: STAINLESS STEEL.
- △ SOCKET CONTACT AND POST: 2.54um [.000100] MIN TIN-LEAD OVER 1.27um [.000050] MIN NICKEL.
- △ SOCKET CONTACT AND POST: 2.54um [.000100] MIN TIN OVER 1.27um [.000050] MIN NICKEL.
- △ OBSOLETE PARTS: OBSOLETE CIS STREAMLINING PER D.RENAUD/D.SINISI

△ OBSOLETE	△	B, C, D, E, F, H, I, J, L, M, N	1-213928-4
△ OBSOLETE	△	A, B, C, D, E, F, G, H, K	-1-213928-3
△	△	A, B, C, D, E, K	1-213928-2
△	△	ALL	1-213928-1
OBSOLETE	△	B, C, D, E, F, H, I, J, L, M, N	-213928-4
OBSOLETE	△	A, B, C, D, E, F, G, H, K	-213928-3
OBSOLETE	△	A, B, C, D, E, K	-213928-2
OBSOLETE	△	ALL	-213928-1
		FINISH	POSITIONS LOADED
			PART NUMBER

THIS DRAWING IS A CONTROLLED DOCUMENT.

DIMENSIONS: mm [INCHES]	TOLERANCES UNLESS OTHERWISE SPECIFIED:	DIN C. OBERMAN 31 OCT 95	APVD R. STONE 1 NOV 95	TE Connectivity
0 PLC ± -	1 PLC ± -	APVD R. BYERS 2 NOV 95	NAME	
2 PLC ± 0.13 [.005]	3 PLC ± -		PRODUCT SPEC	RECEPTACLE ASSEMBLY, 20-14, REVERSE SEX, CPC
4 PLC ± -	ANGLES ± -		APPLICATION SPEC	SIZE CASE CODE DRAWING NO
MATERIAL	FINISH	WEIGHT	RESTRICTED TO	A1 00779 C=213928
			CUSTOMER DRAWING	SCALE 4:1 SHEET 1 OF 1 REV C3