

THIS DRAWING IS UNPUBLISHED.

RELEASED FOR PUBLICATION

ALL RIGHTS RESERVED.

© COPYRIGHT - By -

REVISIONS

P	LTR	DESCRIPTION	DATE	DWN	APVD
	B2	REVISED PER ECO-16-004800	08SEP2016	NK	MZ
	C	REVISED PER ECR-16-016563	07DEC2016	RS	MZ

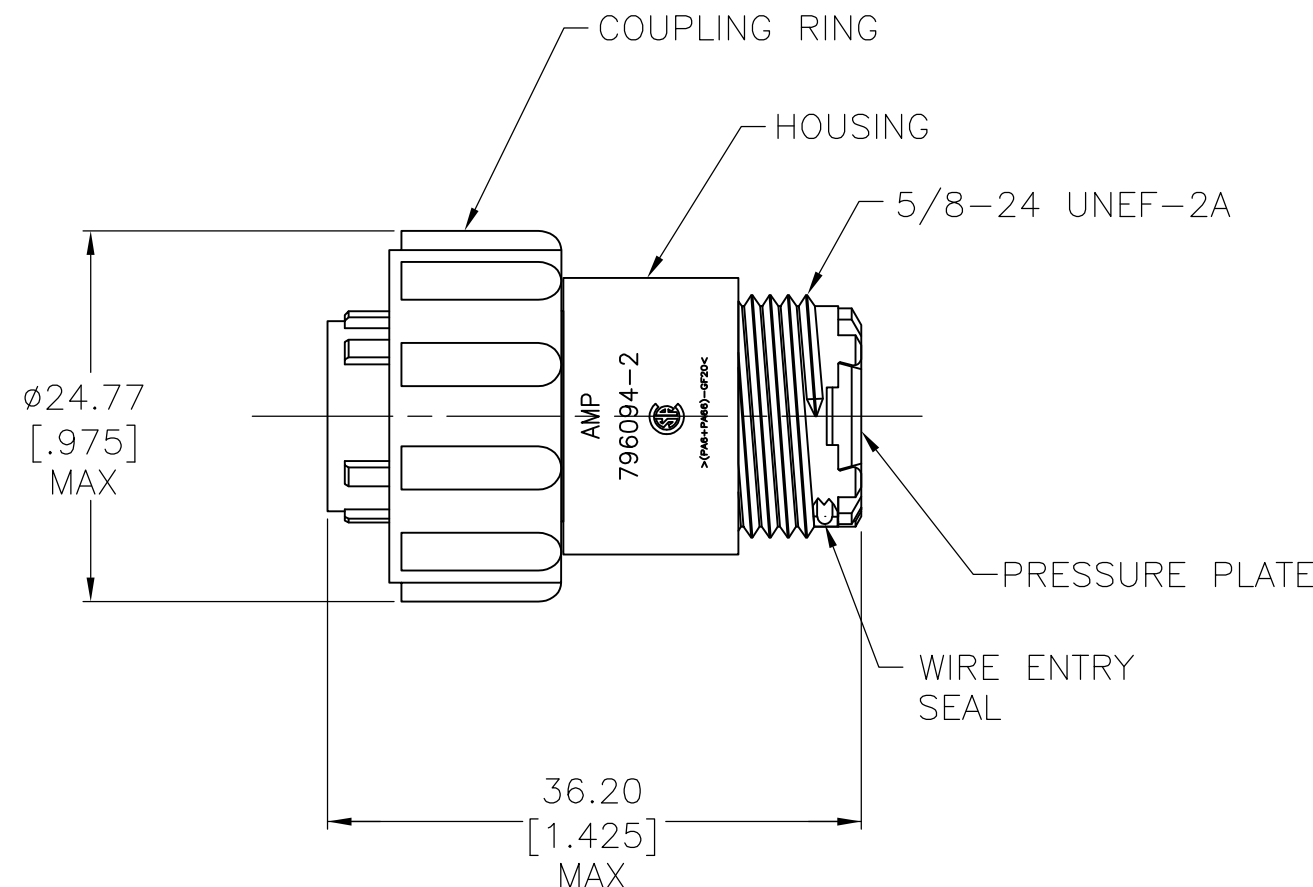
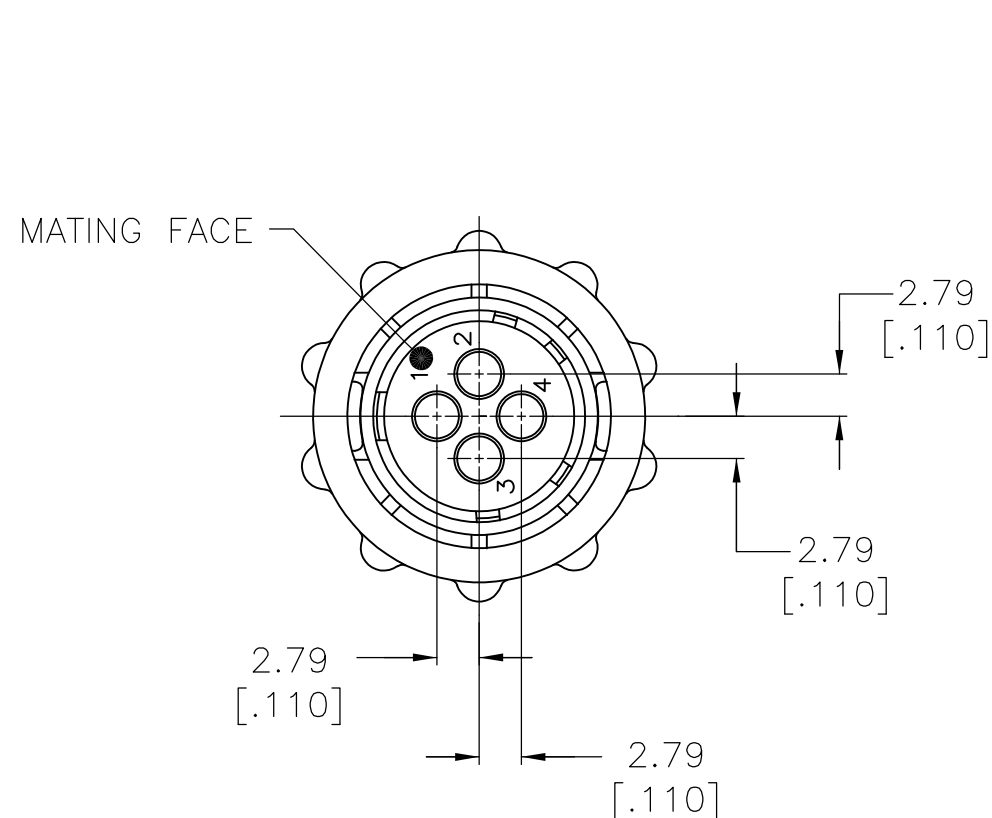

1 THIS PART WILL ACCEPT FOUR (4) MULTIMATE SOCKET CONTACTS.

2 COUPLING RING, HOUSING, AND PRESSURE PLATE: NYLON, BLACK. WIRE ENTRY SEAL: ELASTOMER, RED-IRON OXIDE.

OBSOLETE	PULL FREE	796094-4
OBSOLETE	METAL	796094-3
	STANDARD	796094-2
	COUPLING RING STYLE	PART NUMBER

THIS DRAWING IS A CONTROLLED DOCUMENT.		DWN C.DORWART 31 AUG 98	STE TE Connectivity	
DIMENSIONS: mm [INCHES]		CHK R.WALTER 31 AUG 98		
TOLERANCES UNLESS OTHERWISE SPECIFIED:		APVD R.WALTER 31 AUG 98	NAME PLUG ASSEMBLY, 11-4, STANDARD SEX, SERIES I, SEALED, CIRCULAR PLASTIC CONNECTOR	
0 PLC ± -		PRODUCT SPEC	SIZE	
1 PLC ± -		APPLICATION SPEC	CAGE CODE	
2 PLC ± 0.13 [.005]		WEIGHT	DRAWING NO	
3 PLC ± -		MATERIAL	RESTRICTED TO	
4 PLC ± -			A3 00779 C-796094	
ANGLES ± -		CUSTOMER DRAWING		SCALE 2:1
FINISH		SHEET 1 OF 1		REV C