

Installation Instructions for the MICRO SWITCH NGC Series Compact Limit Switches

Issue 5

32313117

⚠ WARNING PERSONAL INJURY

DO NOT USE these products as safety or emergency stop devices or in any other application where failure of the product could result in personal injury.

Failure to comply with these instructions could result in death or serious injury.

ROUTINE MAINTENANCE

It is important to appreciate that the safe operation of your machine will depend upon the safe efficient working of all components and devices, which would include these switches. It is essential that a regular maintenance routine for the machine is established and that the routine should specifically cover all components that interface with these switches. It is imperative that any wear on the actuator mechanism operating the switch, or on the switch itself, and also any drift in the operating characteristics are identified at an early stage and the necessary corrective actions implemented by the end user, thus ensuring operator safety.

Periodic maintenance of the switch and replacement at appropriate intervals will avoid failures due to wear. The frequency of the maintenance will be determined by the type of machinery and is the responsibility of the machine manufacturer or end user. The switch actuator must not be traveled to the point where it reaches its physical end stop, or beyond, as damage could occur. It is good design practice not to hold the switch actuator in the overtravel position for extended periods, that the actuator moves freely without jamming during operation and that the alignment of the machine actuator to the switch prevents damage or excessive wear. The electrical operation of the switch must be checked and tested at regular intervals only by a suitably qualified person.

⚠ ATTENTION BLESSURES CORPORELLES

NE PAS UTILISER ces produits en tant que dispositifs d'arrêt d'urgence ou de sécurité, ni dans aucune autre application où la défaillance du produit pourrait entraîner des blessures corporelles.

L'inobservation de ces instructions peut entraîner la mort ou de graves blessures.

ENTRETIEN COURANT

Il est important de se rappeler que le bon fonctionnement de votre machine dépendra de l'usage correct de tous les composants et dispositifs y compris des interrupteurs de fin de course. Un entretien régulier de la machine est essentiel et doit être établi, cet entretien doit couvrir tous les composants qui interagissent avec ces interrupteurs. Il est impératif que toute usure du mécanisme de l'actionneur opérant l'interrupteur, ou l'usure de l'interrupteur lui-même, ou encore toute variation des caractéristiques de fonctionnement, soit identifiée le plus tôt possible et que les mesures correctives nécessaires soient prises par l'utilisateur, assurant ainsi la sécurité de l'opérateur.

L'entretien régulier de l'interrupteur et son remplacement à des intervalles appropriés évitera les pannes dues à l'usure. La fréquence d'entretien est déterminée par le type de machine et est la responsabilité du fabricant ou de l'utilisateur de la machine. L'actionneur du fin de course ne doit pas être déplacé au-delà du point où il atteint sa propre butée pour éviter de l'endommager. Il est préférable de ne pas maintenir l'actionneur de l'interrupteur en position de surcourse pendant des périodes prolongées. Durant le fonctionnement, l'actionneur doit pouvoir se déplacer librement sans se coincer et son alignement avec l'interrupteur doit empêcher les risques d'endommagement ou d'usure excessive. Le fonctionnement du fin de course sous tension doit être vérifié et testé à des intervalles réguliers par du personnel qualifié uniquement.

⚠️ WARNUNG PERSONENSCHADEN

Diese Produkte dürfen weder als Sicherheits- oder Not-Abschaltgeräte noch in anderen Anwendungen, bei denen ein Fehler an diesem Produkt zu Personenschaden führen könnte, eingesetzt werden.

Missachtung dieser Anweisungen kann zu schweren Verletzungen oder zum Tod führen.

ROUTINEWARTUNG

Es muß betont werden, daß der sichere Betrieb ihrer Maschine vom sicheren und wirksamen Betrieb aller Komponenten und Vorrichtungen abhängt, zu denen auch diese Schalter gehören. Besonders wichtig ist es, eine regelmäßige Wartungsroutine für die Maschine einzurichten, die insbesondere alle Komponenten mit berücksichtigt, die in Verbindung mit diesen Schaltern verwendet werden. Verschleißerscheinungen am Betätigungsmechanismus des Schalters oder am Schalter selbst, sowie jede Veränderung der Schaltbetätigungs-Kenndaten, müssen unbedingt bereits im Anfangsstadium erkannt und vom Endnutzer behoben werden, um die Sicherheit des Bedienenden zu gewährleisten.

Durch regelmäßige Wartung des Schalters und Auswechseln in angemessenen Zeitabständen werden Störungen infolge von Abnutzung vermieden. Das Wartungsintervall richtet sich nach der Art der Maschine und liegt in der Verantwortung des Herstellers oder Endnutzers. Um Schäden zu vermeiden, darf der Schalterbetätiger nicht bis zum Endanschlag oder darüber hinaus ausgefahren werden. Der Einbau des Schalters muß so ausgeführt werden, daß der Schalterbetätiger nicht über einen längeren Zeitraum hinweg in Nachlaufwegposition betätigt wird, und er sollte sich leicht bewegen lassen, ohne beim Betätigen zu klemmen. Die Ausrichtung des Maschinenbetätigers mit dem Schalter soll der Vorbeugung gegen Schäden oder übermäßige Abnutzung dienen. Der elektrische Betrieb des Schalters muß geprüft und in regelmäßigen Zeitabständen von einer entsprechend qualifizierten Person getestet werden.

Conforming to standards	Conforme aux standards	Entspricht den Normen	IEC 60947-5-1, IEC 61373, EN45545-2 HL 3 (metal variants with M12 connectors only)	
Utilization category	Catégorie d'utilisation	Verwendungskategorie	1NC/1NO (silver-alloy contacts)	A300 AC15: 120 V 6 A; 240 V 3 A per IEC 60947-5-1 and UL 508 Q300 DC13: 125 Vdc 0.55 A; 250 Vdc 0.27 A per IEC 60947-5-1 and UL 508
			1NC/1NO (gold-plated contacts)	low level current: 30 mVdc 10 mA resistive
			2NC/2NO (silver-alloy contacts)	C300 AC15: 0.75 A 240 Vac per IEC 60947-5-1 R300 DC13: 0.1 A 250 Vdc per IEC 60947-5-1
			2NC/2NO (gold-plated contacts)	low level current: 30 mVdc 10 mA resistive
Thermal current	Courant permanent maximum (Ith)	Dauerstrom (Ith)	1NC/1NO: 10 A 2NC/2NO: 5 A	
Rated Insulation voltage (Ui)	Tension efficace (Ui)R	Nennisolationsspannung (Ui)	1NC/1NO: 400 V as per IEC 60947-5-1 2NC/2NO: 250 V as per IEC 60947-5-1	
Rated impulse withstand voltage (Uimp)	Tension d'isolment (Uimp)	Max.Impuls-Prufspannung (Uimp)	1NC/1NO: 2500 V as per IEC 60947-5-1 2NC/2NO: 1500 V as per IEC 60947-5-1	
Pollution degree	Degré de pollution	Verschmutzungsgrad	3 (III)	
Operating temperature	Température de fonctionnement	Betriebstemperatur	-25 °C to 75 °C [-13 °F to 167 °F]	
Mechanical life	Durée de vie mécanique	Mechanische Lebensdauer	1NC/1NO: 5 M cycles min at 120 CPM 2NC/2NO: 5 M cycles min at 60 CPM	
Degree of protection	Indice de protection	Schutzart	NEMA 1, 4, 12, 13; IP67 per IEC 60529	
Min. actuation speed	Vitesse min. de la clé	Min. Betaetigungsgeschwindigkeit	0,3 mm/s	
Max. actuation speed	Vitesse max. de la clé	Max. Betaetigungsgeschwindigkeit	2 m/s	
Max. actuation frequency	Fréquence max. de pénétration	Max. Betaetigungsfrequenz	1NO/1NC: 120 cpm 2NO/2NC: 60 cpm	
Shock	Choc	Stossfestigkeit	50 g for 11 ms as per IEC 60068-2-27; railway application, per IEC 61373 Class I Car B type	
Vibration	Vibration	Vibrationfestigkeit	10 G as per IEC60068-2-6; Railway application per IEC61373 Class I Car B type	
Allowable panel thickness	Epaisseur de panneau autorisée	Zulässige Tafeldicke	7,0 mm [0.28 in] max.	
Mounting holes	Trous de montage	Befestigungslöcher	M4 or #8 screws	
Tightening torque	Couple de serrage	Anzugsmoment	1,5 Nm to 2,0 Nm [13.27 in-lb to 17.7 in-lb]	

Figure 1. Product Nomenclature and Order Guide

NGC	M	A	02	A	X	01	A	1	1	
Switch Type	Housing	Connection	Cable Length	Connector/Cable Exiting Housing	Connector at End of Cable	Switch Type	Head Type	Levers (Optional)	Rollers (Optional)	Modifications
NGC Series Medium-Duty Compact Limit Switch	M Metal	A Side exit, right	00 No cable. Internal connector	A Standard cable	X None	01 1NC/1NO snap action silver contacts	A Side rotary	None	None	M01 Side rotary lever, 90° right
	P Plastic	B Bottom exit	02 0.25 m [0.82 ft]	B Halogen-free cable		07 1NC/1NO snap action gold contacts	B Pin plunger	1 Standard, fixed length ¹	A 18 mm nylon roller ²	M02 Side rotary lever, 90° left
	Q Plastic with mounting ring support	C Side exit, left	05 0.5 m [1.64 ft]	D PUR cable		24 2NC/2NO snap action silver contacts	C Roller plunger	2 Adjustable length, roller lever ¹	B 18 mm stainless steel roller ²	M07 Side rotary short lever, 45° right
			07 0.7 m [2.3 ft]	N M12 4-pin micro change, dc connector ^{5,6}		32 2NC/2NO snap action gold contacts	D Long pin plunger	6 Short, fixed length ¹	C 18 mm nylon roller, reversed ³	M08 Side rotary short lever, 45° left
			10 1.0 m [3.28 ft]	P M12 5-pin micro change, dc connector ^{5,6}			J Top roller lever arm		D 18 mm stainless steel roller, reversed ³	
			15 1.5 m [4.92 ft]	R Railway cable ⁷			L Cross roller plunger			
			20 2.0 m [6.56 ft]				M Pin plunger w/ boot seal			
			30 3.0 m [9.84 ft]				N Panel-mount pin plunger			
			40 4.0 m [13.12 ft]				P Panel-mount roller plunger			
			50 5.0 m [16.4 ft]				Q Panel-mount cross-roller plunger			
						R Panel-mount pin plunger w/ boot seal				
						S Long roller plunger				
						T Long cross-roller plunger				

NOTE: not all combinations of model code are available. Please contact your Honeywell provider/representative for assistance.

¹ Only applicable for head type "A"
² Only applicable for lever types "1, 2, 6" and switch types "01" and "07"
³ Only applicable for lever types "2, 6"
⁴ Only applicable for metal housing Type "M"
⁵ Typically applicable for plastic housing Type "P" and "Q", and without grounding metal housing Type "M"
⁶ Only applicable for switch type "01" and "07"
⁷ Cable meets EN 50306, but does not meet with UL requirement

Figure 2. Connector Dimensions and Pin-Out Identification

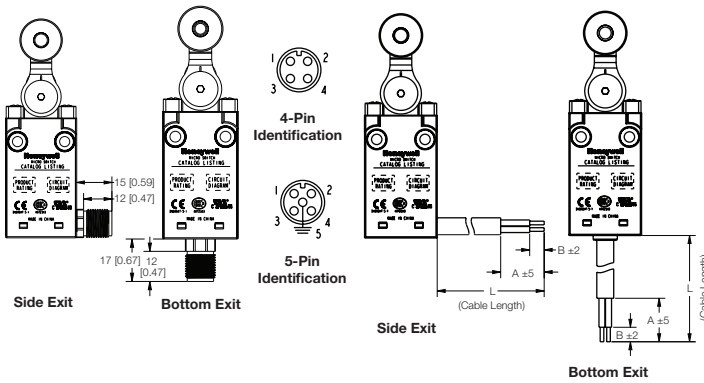
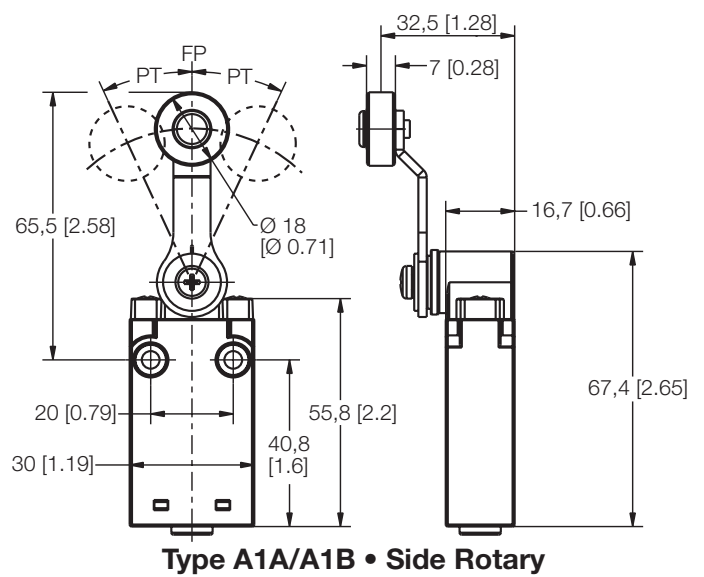

Figure 3. Side Rotary A1A/A1B Dimensions



NOTE: Connector option only available for SPDT versions.

Figure 4. Side Rotary A6A/A6B Dimensions

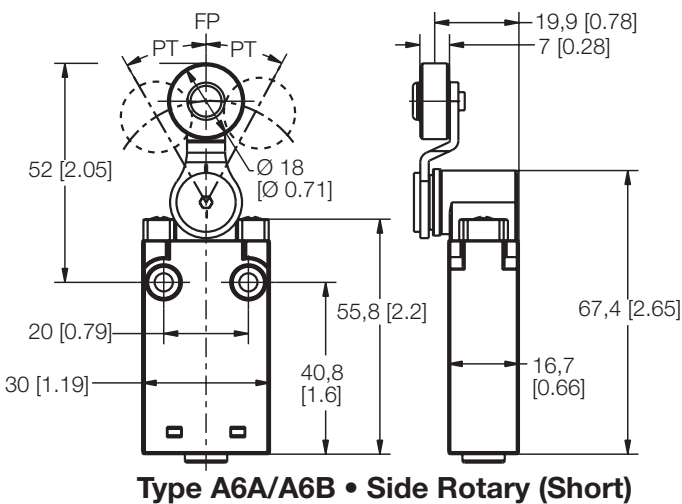

Figure 5. Side Rotary A2A/A2B Dimensions

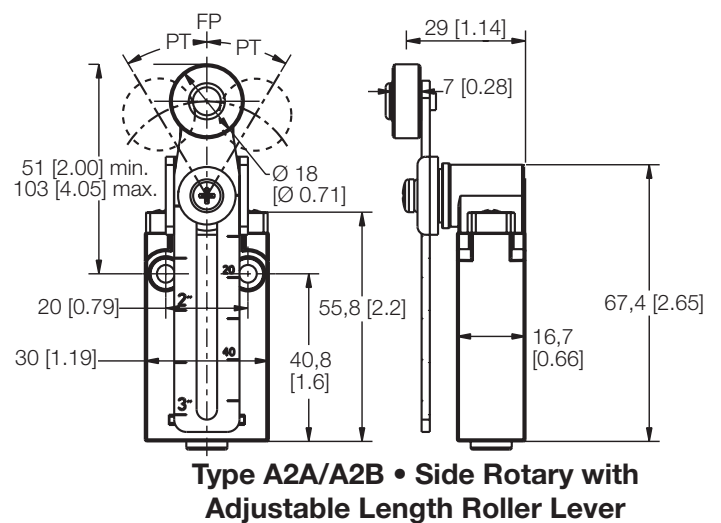

Figure 6. Side Rotary A6C/A6D Dimensions

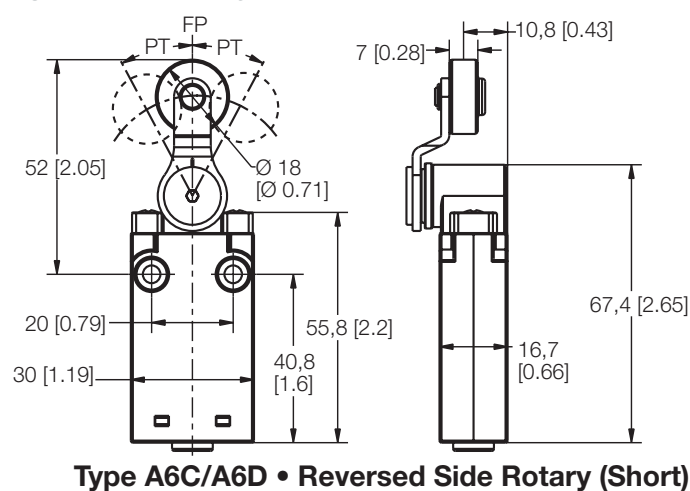

Figure 7. Side Rotary A2C/A2D Dimensions

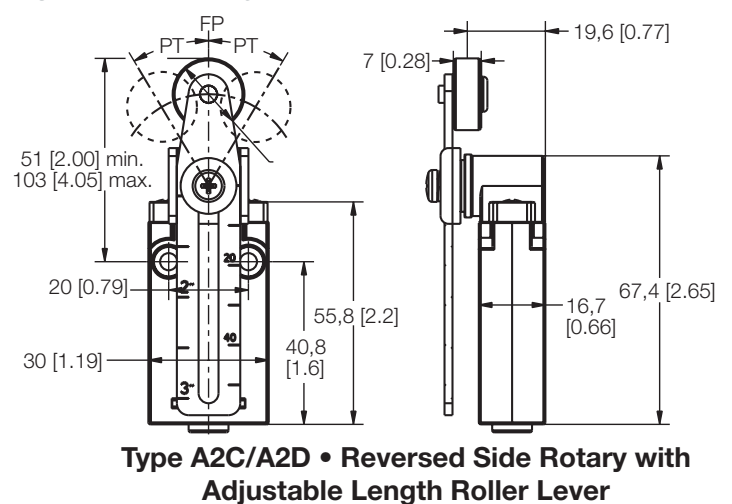
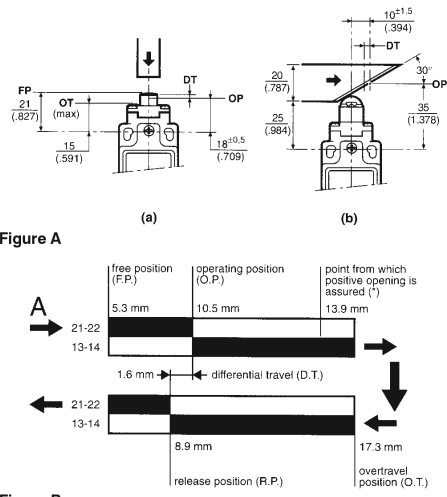

Table 2. Side Rotary Operating Characteristics

Actuation	Catalog Listing	Connector/ Cable Exit	Switch Type	Circuit Diagram	Bar Charts	Differential Travel max.	Operat- ing Force/ Torque max.	Release Force/ Torque max.
Side Rotary	NGCP****X01A**	A	01			15°	18 Ncm [1.59 in-lb]	2,5 Ncm [0.22 in-lb]
	NGCP****X01A**	B						
	NGCP****X01A**	D						
	NGCP****X07A**	A	07			15°	18 Ncm [1.59 in-lb]	2,5 Ncm [0.22 in-lb]
	NGCP****X07A**	B						
	NGCP****X07A**	D						
	NGCP****X01A**	N	01			15°	18 Ncm [1.59 in-lb]	2,5 Ncm [0.22 in-lb]
	NGCP****X07A**	N						
	NGCM****X01A**	A						
	NGCM****X01A**	B	01			15°	18 Ncm [1.59 in-lb]	2,5 Ncm [0.22 in-lb]
	NGCM****X01A**	D						
	NGCM****X07A**	A						
	NGCM****X07A**	B	07			15°	18 Ncm [1.59 in-lb]	2,5 Ncm [0.22 in-lb]
	NGCM****X07A**	D						
	NGCM****X01A**	P						
	NGCM****X07A**	P	07			15°	18 Ncm [1.59 in-lb]	2,5 Ncm [0.22 in-lb]
	NGCM****X01A**	A						
	NGCM****X01A**	B						
NGCP****X24A**	A	24			16.5°	17 Ncm [1.5 in-lb]	2,1 Ncm [0.19 in-lb]	
NGCP****X24A**	B							
NGCP****X24A**	D							
NGCP****X32A**	A	32			16.5°	17 Ncm [1.5 in-lb]	2,1 Ncm [0.19 in-lb]	
NGCP****X32A**	B							
NGCP****X32A**	D							
NGCM****X24A**	A	24			16.5°	17 Ncm [1.5 in-lb]	2,1 Ncm [0.19 in-lb]	
NGCM****X24A**	B							
NGCM****X24A**	D							
NGCM****X32A**	A	32			16.5°	17 Ncm [1.5 in-lb]	2,1 Ncm [0.19 in-lb]	
NGCM****X32A**	B							
NGCM****X32A**	D							



How to read and understand the bar chart information

The following example relates to a unit which has a snap action basic and which has a roller pin plunger actuator. Follow the black arrows and the black strip on the chart. The black strip indicates that there is a circuit between the terminals whose numbers are shown on the left and when white there is no circuit.

Look at Figures A and B as examples. Actuator type used for test is the linear Cam travel type (b) shown left. The start point is at the arrow marked "A" (See fig. B). This shows the free position to be 5.3 mm from the vertical center line of the unit. At this stage there is a circuit between the terminals 21-22 but no circuit between terminals 13-14. The unit can be actuated until it reaches the operating position which is 10,5 mm from the center line – a travel distance of 10,5 – 5,3 = 5,2 mm from the free position. At this point the circuit arrangement changes – no circuit between 21-22 but making a circuit between 13-14. If, however, the contacts of terminals 21-22 weld together and will not separate, a mechanical safety feature will take effect if the switch is travelled past the point from which positive opening is assured, 13,9 mm. As the switch returns it reaches the release position at 8.9 mm from the center line. The circuit will change back to the original state and the difference between the operating position and the release position gives what is known as the differential travel i.e. 10,5 – 8,9 = 1,6 mm. The asterisk (*) indicates the point from which the positive opening is assured.

Figure 8. Pin Plunger B & D Dimensions

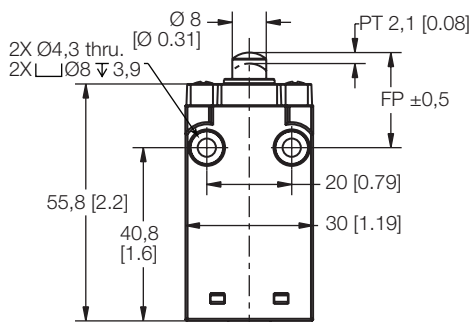

NGC_B | FP 19,8 mm
NGC_D | FP 22,4 mm
Pin Plunger

Figure 9. Roller Plunger C & S Dimensions

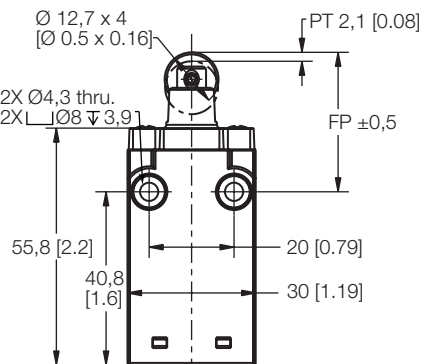

NGC_C | FP 30,3 mm
NGC_S | FP 32,85 mm
Roller Plunger

Figure 10. Cross Roller Plunger L & T Dimensions

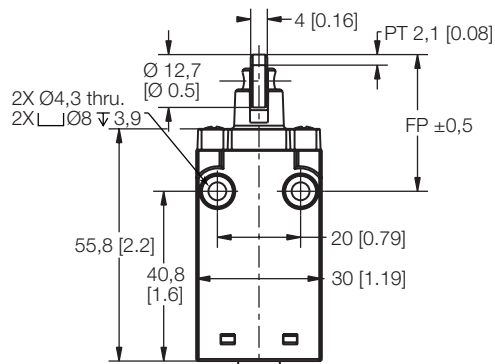

NGC_L | FP 30,3 mm
NGC_T | FP 32,85 mm
Cross Roller Plunger

Figure 11. Pin Plunger with Boot Seal M Dimensions

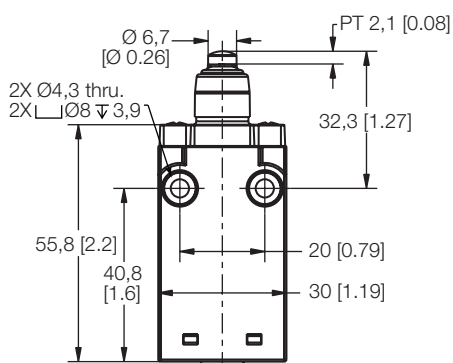

NGC_M
Pin Plunger with Boot Seal

Figure 12. Panel-Mount Pin Plunger N Dimensions

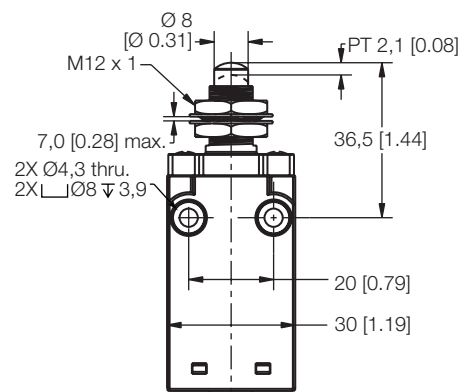

NGC_N
Panel-Mount Pin Plunger

Figure 13. Panel-Mount Roller Plunger P Dimensions

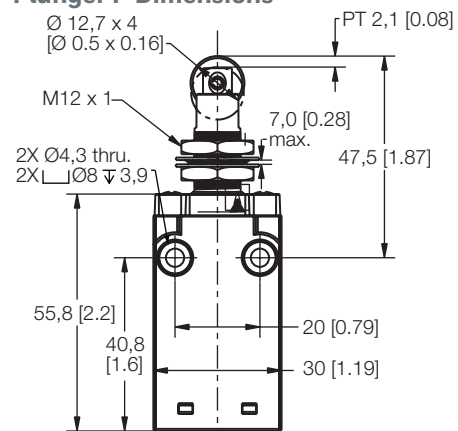

NGC_P
Panel-Mount Roller Plunger

Figure 14. Panel-Mount Cross Roller Plunger Q Dimensions

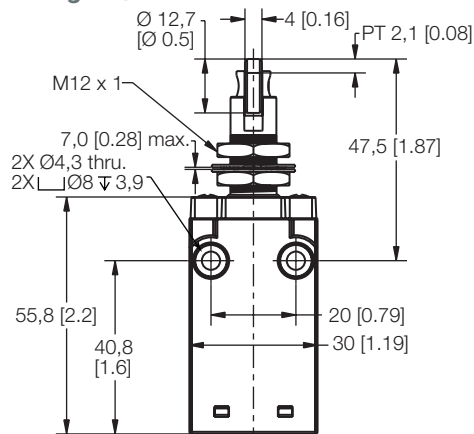

NGC_Q
Panel-Mount Cross Roller Plunger

Figure 15. Panel-Mount Pin Plunger With Boot Seal R Dimensions

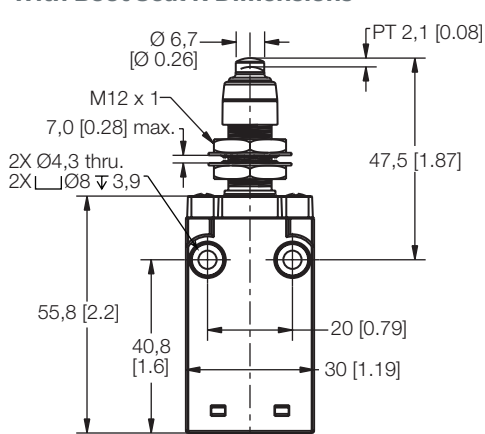

NGC_R
Panel-Mount Pin Plunger with Boot Seal

Figure 16. Top Roller Lever Arm J Dimensions

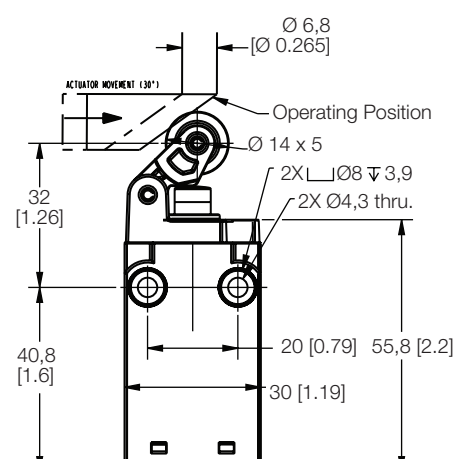

NGC_J
Top Roller Lever Arm
 Sensing and Internet of Things **7**

Table 3. Plunger Operating Characteristics

Actuation	Catalog Listing	Connector/ Cable Exit	Switch Type	Circuit Diagram	Bar Charts	Dif-ferential Travel max.	Operat- ing Force/ Torque max.	Release Force/ Torque max.				
Plung- er Head	NGCP*****X01 B/C/D/L/M/N/P/Q/R/S/T	A	01		<p>DT</p> <p>■ Contact Closed □ Contact Open * Positive Opening</p>	1,2 mm [0.047 in]	11 N [2.47 lb]	3 N [0.67 lb]				
	NGCP*****X01 B/C/D/L/M/N/P/Q/R/S/T	B										
	NGCP*****X01 B/C/D/L/M/N/P/Q/R/S/T	D										
	NGCP*****X07 B/C/D/L/M/N/P/Q/R/S/T	A	07									
	NGCP*****X07 B/C/D/L/M/N/P/Q/R/S/T	B										
	NGCP*****X07 B/C/D/L/M/N/P/Q/R/S/T	D										
	NGCP*****X01 B/C/D/L/M/N/P/Q/R/S/T	N	01		<p>DT</p> <p>■ Contact Closed □ Contact Open * Positive Opening</p>	1,2 mm [0.047 in]	11 N [2.47 lb]	3 N [0.67 lb]				
	NGCP*****X07 B/C/D/L/M/N/P/Q/R/S/T	N	07									
	NGCM*****X01 B/C/D/L/M/N/P/Q/R/S/T	A	01						<p>DT</p> <p>■ Contact Closed □ Contact Open * Positive Opening</p>	1,2 mm [0.047 in]	11 N [2.47 lb]	3 N [0.67 lb]
	NGCM*****X01 B/C/D/L/M/N/P/Q/R/S/T	B										
	NGCM*****X01 B/C/D/L/M/N/P/Q/R/S/T	D										
	NGCM*****X07 B/C/D/L/M/N/P/Q/R/S/T	A	07									
	NGCM*****X07 B/C/D/L/M/N/P/Q/R/S/T	B										
	NGCM*****X07 B/C/D/L/M/N/P/Q/R/S/T	D										
	NGCM*****X01 B/C/D/L/M/N/P/Q/R/S/T	P	01		<p>DT</p> <p>■ Contact Closed □ Contact Open * Positive Opening</p>	1,2 mm [0.047 in]	11 N [2.47 lb]	3 N [0.67 lb]				
	NGCP*****X07 B/C/D/L/M/N/P/Q/R/S/T	P	07									
NGCP*****X24 B/C/D/L/M/N/P/Q/R/S/T	A	24		<p>DT</p> <p>■ Contact Closed □ Contact Open * Positive Opening</p>					1,4 mm [0.055 in]	9,5 N [2.14 lb]	2,2 N [0.49 lb]	
NGCP*****X24 B/C/D/L/M/N/P/Q/R/S/T	B											
NGCP*****X24 B/C/D/L/M/N/P/Q/R/S/T	D											
NGCP*****X32 B/C/D/L/M/N/P/Q/R/S/T	A	32										<p>DT</p> <p>■ Contact Closed □ Contact Open * Positive Opening</p>
NGCP*****X32 B/C/D/L/M/N/P/Q/R/S/T	B											
NGCP*****X32 B/C/D/L/M/N/P/Q/R/S/T	D											
NGCM*****X24 B/C/D/L/M/N/P/Q/R/S/T	A	24		<p>DT</p> <p>■ Contact Closed □ Contact Open * Positive Opening</p>	1,4 mm [0.055 in]	9,5 N [2.14 lb]	2,2 N [0.49 lb]					
NGCM*****X24 B/C/D/L/M/N/P/Q/R/S/T	B											
NGCM*****X24 B/C/D/L/M/N/P/Q/R/S/T	D											
NGCM*****X32 B/C/D/L/M/N/P/Q/R/S/T	A	32						<p>DT</p> <p>■ Contact Closed □ Contact Open * Positive Opening</p>	1,4 mm [0.055 in]	9,5 N [2.14 lb]	2,2 N [0.49 lb]	
NGCM*****X32 B/C/D/L/M/N/P/Q/R/S/T	B											
NGCM*****X32 B/C/D/L/M/N/P/Q/R/S/T	D											

Table 4. Plunger Operating Characteristics, Head Type J

Actuation	Catalog Listing	Connector/ Cable Exit	Switch Type	Circuit Diagram	Bar Charts	Differential Travel max.	Operating Force/ Torque max.	Release Force/ Torque max.
Top Roller Arm	NGCP*****X01 J	A	01			4 mm [0.157 in]	5,5 N [1.24 lb]	1,2 N [0.27 lb]
	NGCP*****X01 J	B						
	NGCP*****X01 J	D						
	NGCP*****X07 J	A	07			4 mm [0.157 in]	5,5 N [1.24 lb]	1,2 N [0.27 lb]
	NGCP*****X07 J	B						
	NGCP*****X07 J	D						
	NGCP*****X01 J	N	01			4 mm [0.157 in]	5,5 N [1.24 lb]	1,2 N [0.27 lb]
	NGCP*****X07 J	N						
	NGCM*****X01 J	A	01			4 mm [0.157 in]	5,5 N [1.24 lb]	1,2 N [0.27 lb]
	NGCM*****X01 J	B						
	NGCM*****X01 J	D						
	NGCM*****X07 J	A	07			4 mm [0.157 in]	5,5 N [1.24 lb]	1,2 N [0.27 lb]
	NGCM*****X07 J	B						
	NGCM*****X07 J	D						
	NGCM*****X01 J	P	01			4 mm [0.157 in]	5,5 N [1.24 lb]	1,2 N [0.27 lb]
	NGCP*****X07 J	P						
	NGCP*****X24 J	A	24			4,3 mm [0.169 in]	4,5 N [1.01 lb]	1,2 N [0.27 lb]
	NGCP*****X24 J	B						
	NGCP*****X24 J	D						
	NGCP*****X32 J	A	32			4,3 mm [0.169 in]	4,5 N [1.01 lb]	1,2 N [0.27 lb]
NGCP*****X32 J	B							
NGCP*****X32 J	D							
NGCM*****X24 J	A	24			4,3 mm [0.169 in]	4,5 N [1.01 lb]	1,2 N [0.27 lb]	
NGCM*****X24 J	B							
NGCM*****X24 J	D							
NGCM*****X32 J	A	32			4,3 mm [0.169 in]	4,5 N [1.01 lb]	1,2 N [0.27 lb]	
NGCM*****X32 J	B							
NGCM*****X32 J	D							

WARRANTY/REMEDY

Honeywell warrants goods of its manufacture as being free of defective materials and faulty workmanship during the applicable warranty period. Honeywell's standard product warranty applies unless agreed to otherwise by Honeywell in writing; please refer to your order acknowledgement or consult your local sales office for specific warranty details. If warranted goods are returned to Honeywell during the period of coverage, Honeywell will repair or replace, at its option, without charge those items that Honeywell, in its sole discretion, finds defective. **The foregoing is buyer's sole remedy and is in lieu of all other warranties, expressed or implied, including those of merchantability and fitness for a particular purpose. In no event shall Honeywell be liable for consequential, special, or indirect damages.**

While Honeywell may provide application assistance personally, through our literature and the Honeywell web site, it is buyer's sole responsibility to determine the suitability of the product in the application.

Specifications may change without notice. The information we supply is believed to be accurate and reliable as of this writing. However, Honeywell assumes no responsibility for its use.

Honeywell serves its customers through a worldwide network of sales offices, representatives and distributors. For application assistance, current specifications, pricing or name of the nearest Authorized Distributor, contact your local sales office or:

E-mail: info.sc@honeywell.com

Internet: sensing.honeywell.com

Phone and Fax:

USA/Canada +1-800-537-6945

International +1-815-235-6847; +1-815-235-6545 Fax

GARANTIE/RECOURS

La société Honeywell garantit que ses produits sont exempts de défauts matériels et de fabrication, et ce pendant la période de garantie applicable. Sauf indication contraire écrite et approuvée par Honeywell, la garantie standard sur les produits Honeywell s'applique. Veuillez vous reporter au récépissé de votre commande ou consulter votre bureau de vente local pour obtenir des détails spécifiques sur la garantie. Si les articles garantis sont retournés à Honeywell pendant la période de couverture, la société Honeywell réparera ou remplacera, selon son choix et gratuitement, ceux qu'elle estimera, à sa seule discrétion, défectueux. **Ce qui précède constitue le seul recours de l'acheteur et se substitue à toutes autres garanties, explicites ou implicites, y compris celles relatives à la commercialisation ou la compatibilité avec une application particulière. Honeywell ne peut être en aucun cas tenu responsable de tout dommage indirect, spécial ou accessoire.**

Bien que la société Honeywell puisse être amenée à fournir une assistance par le biais de sa documentation et de son site Web, il est de la seule responsabilité de l'acheteur de déterminer pour quelles utilisations le produit est adapté.

Les caractéristiques peuvent être modifiées sans préavis. Les informations fournies dans ce document sont considérées comme fiables et correctes. Toutefois, la société Honeywell ne peut être tenue pour responsables de leur utilisation.

GARANTIE UND HAFTUNGSANSPRÜCHE

Honeywell garantiert, dass die Produkte aus eigener Fertigung während des Gewährleistungszeitraums frei von Materialfehlern und Produktionsmängeln sind. Es gilt die durch Honeywell schriftlich mitgeteilte Standard-Produktgarantie von Honeywell. Informationen zu Garantiedetails finden Sie auf Ihrer Auftragsbestätigung bzw. erhalten Sie von Ihrer örtlichen Niederlassung. Wenn Produkte mit Garantie innerhalb der Garantiefrist an Honeywell zurückgesendet werden, ersetzt oder repariert Honeywell diese Teile kostenlos, sofern sie nach Ermessen von Honeywell als fehlerhaft anzusehen sind. **Das Vorangegangene gilt als einzige Entschädigung des Käufers und ersetzt alle anderen ausdrücklichen oder stillschweigenden Garantien, einschließlich Qualitäts- und Sachmängelhaftung. In keinem Fall haftet Honeywell für mittelbare, indirekte oder Sonderschäden.**

Obwohl Honeywell persönliche und schriftliche Anwendungshilfe sowie Informationen über die Honeywell-Website bietet, liegt es in der ausschließlichen Verantwortung des Kunden, zu entscheiden, ob sich das Produkt für die entsprechende Anwendung eignet.

Änderungen der technischen Daten ohne Vorankündigung sind vorbehalten. Die hier gegebenen Informationen sind nach unserem Wissen zum Zeitpunkt der Erstellung korrekt. Honeywell kann jedoch für deren Verwendung keine Verantwortung übernehmen.

Honeywell Sensing and Internet of Things

9680 Old Bailes Road

Fort Mill, SC 29707

www.honeywell.com

32313117-5-EN IL50 GLO Printed in USA.

May 2017

© 2017 Honeywell International Inc. All rights reserved.

Honeywell