

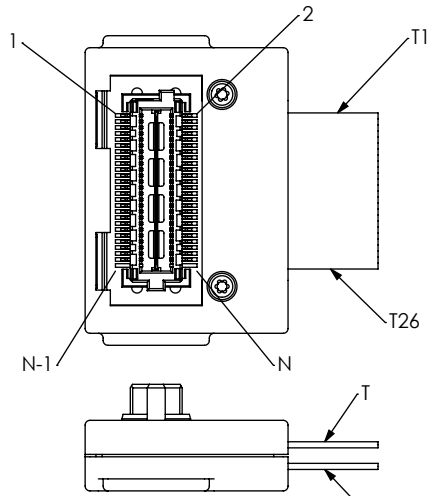

-TR



WIRING OPTION	FIRST END PIN #	SECOND END PIN #	WIRE NUMBER
1	1	1	B1
2	1	2	B1
3	1	N-1	B1
4	1	N	B1

-TL

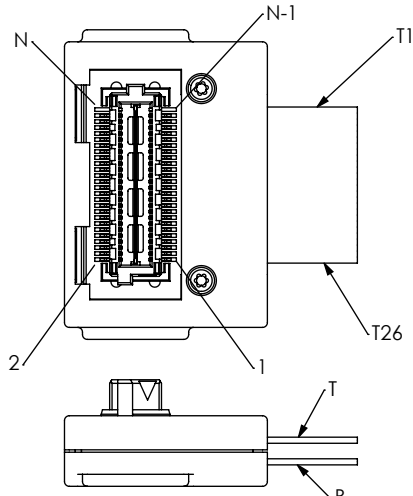

WIRING OPTION	FIRST END PIN #	SECOND END PIN #	WIRE NUMBER
1	1	1	T26
2	1	2	T26
3	1	N-1	T26
4	1	N	T26

-STR

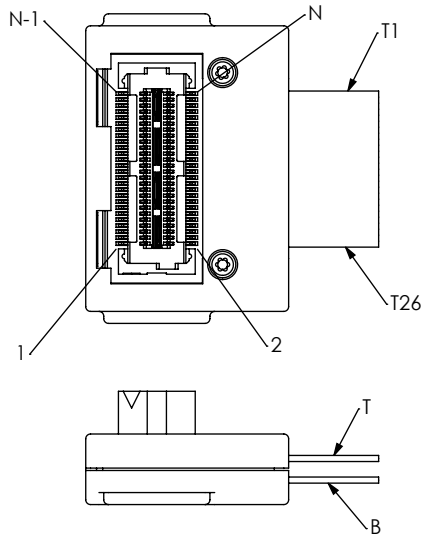

WIRING OPTION	FIRST END PIN #	SECOND END PIN #	WIRE NUMBER
1	1	1	B26
2	1	2	B26
3	1	N-1	B26
4	1	N	B26

-STL

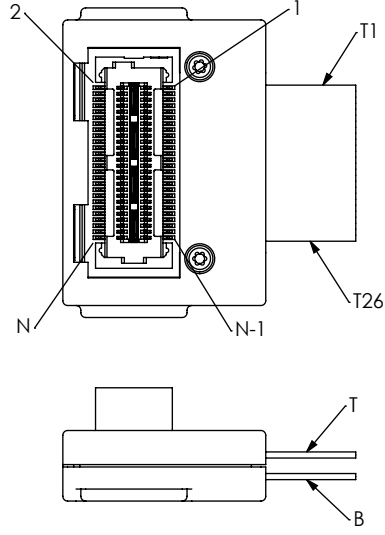

WIRING OPTION	FIRST END PIN #	SECOND END PIN #	WIRE NUMBER
1	1	1	T1
2	1	2	T1
3	1	N-1	T1
4	1	N	T1

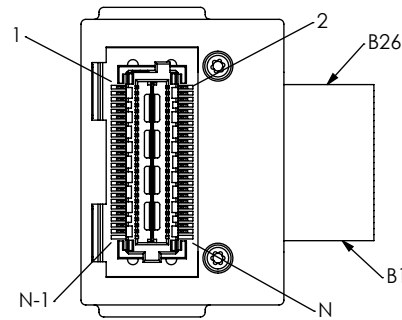
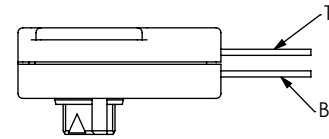

WIRING OPTION	FIRST END PIN #	SECOND END PIN #	WIRE NUMBER
1	1	1	T26
2	1	2	T26
3	1	N-1	T26
4	1	N	T26

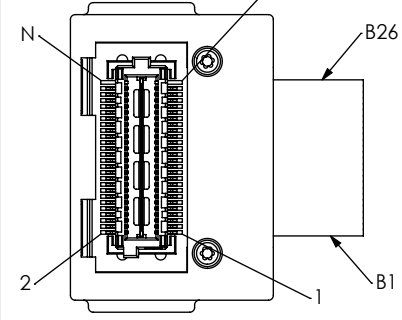
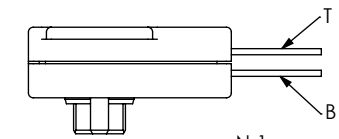
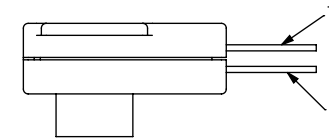

WIRING OPTION	FIRST END PIN #	SECOND END PIN #	WIRE NUMBER
1	1	1	B1
2	1	2	B1
3	1	N-1	B1
4	1	N	B1

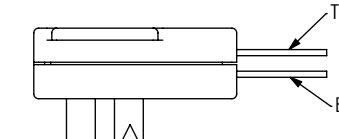

-SBR

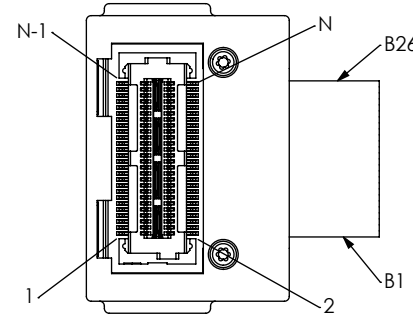

WIRING OPTION	FIRST END PIN #	SECOND END PIN #	WIRE NUMBER
1	1	1	T1
2	1	2	T1
3	1	N-1	T1
4	1	N	T1

-SBL

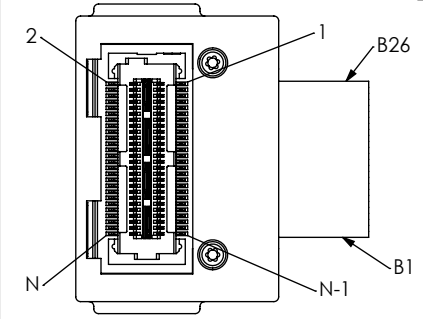

WIRING OPTION	FIRST END PIN #	SECOND END PIN #	WIRE NUMBER
1	1	1	B26
2	1	2	B26
3	1	N-1	B26
4	1	N	B26

PROPRIETARY NOTE  
 THIS DOCUMENT CONTAINS INFORMATION CONFIDENTIAL AND PROPRIETARY TO SAMTEC, INC. AND SHALL NOT BE REPRODUCED OR TRANSFERRED TO OTHER DOCUMENTS OR DISCLOSED TO OTHERS OR USED FOR ANY PURPOSE OTHER THAN THAT WHICH IT WAS OBTAINED WITHOUT THE EXPRESSED WRITTEN CONSENT OF SAMTEC, INC.

DO NOT SCALE DRAWING

SHEET SCALE: 1:25:1



520 PARK EAST BLVD, NEW ALBANY, IN 47150  
 PHONE: 812-944-6733 FAX: 812-948-5047  
 e-Mail: info@SAMTEC.com code: 53322

DESCRIPTION:  
 .635mm HIGH-SPEED COAX CABLE ASSEMBLY

DWG. NO.  
 6QCD-XXX-XX.XX-XXX-XXX-X-X

BY: D. FRALEY 03/14/2006 SHEET 2 OF 7

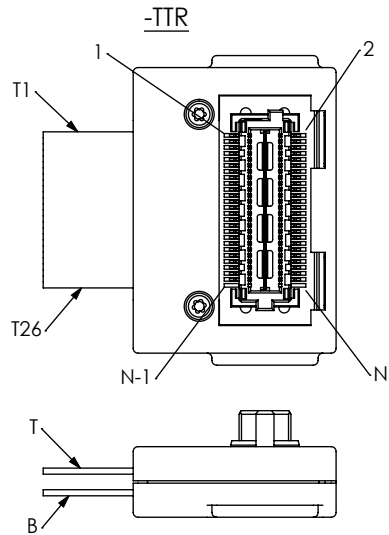

WIRING OPTION	FIRST END PIN #	SECOND END PIN #
1	1	1
2	1	2
3	1	N-1
4	1	N

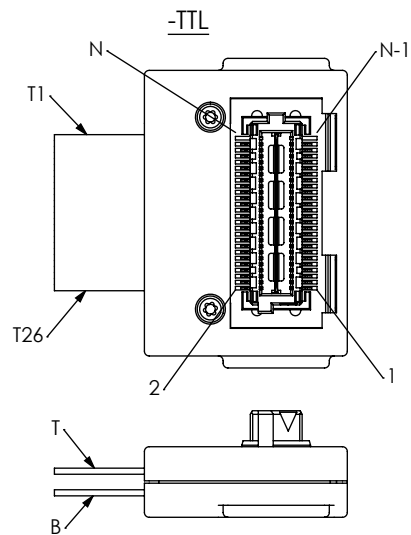

WIRING OPTION	FIRST END PIN #	SECOND END PIN #
1	1	1
2	1	2
3	1	N-1
4	1	N

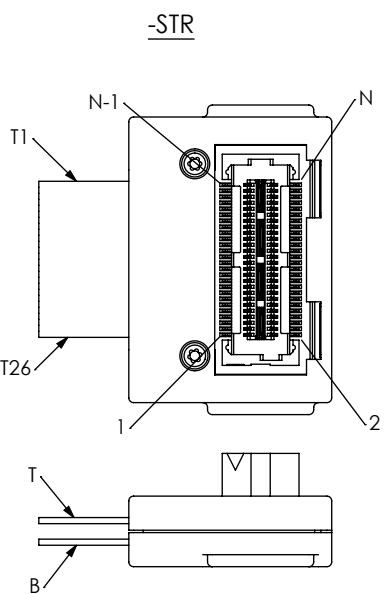

WIRING OPTION	FIRST END PIN #	SECOND END PIN #
1	1	1
2	1	2
3	1	N-1
4	1	N

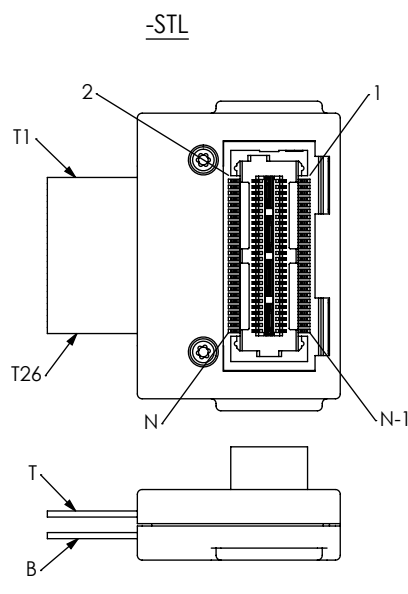

WIRING OPTION	FIRST END PIN #	SECOND END PIN #
1	1	1
2	1	2
3	1	N-1
4	1	N

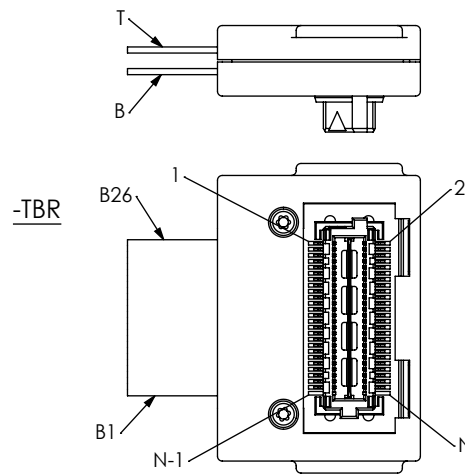

WIRING OPTION	FIRST END PIN #	SECOND END PIN #
1	1	1
2	1	2
3	1	N-1
4	1	N

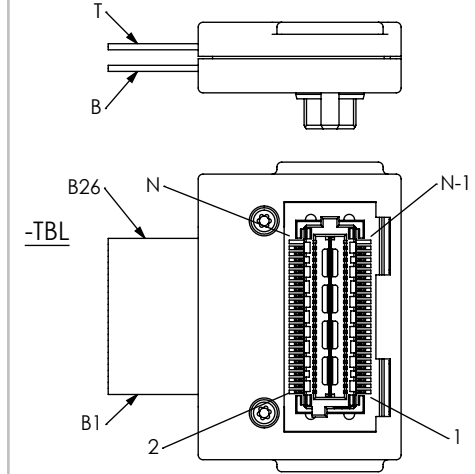

WIRING OPTION	FIRST END PIN #	SECOND END PIN #
1	1	1
2	1	2
3	1	N-1
4	1	N

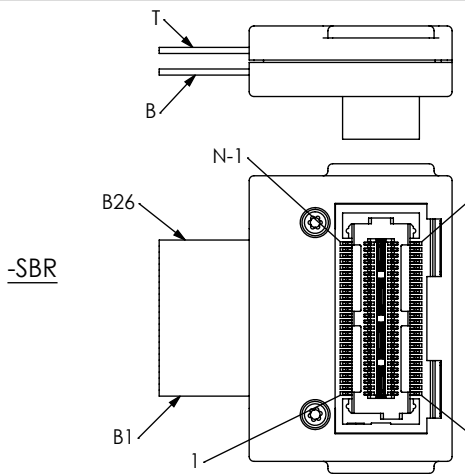

WIRING OPTION	FIRST END PIN #	SECOND END PIN #
1	1	1
2	1	2
3	1	N-1
4	1	N

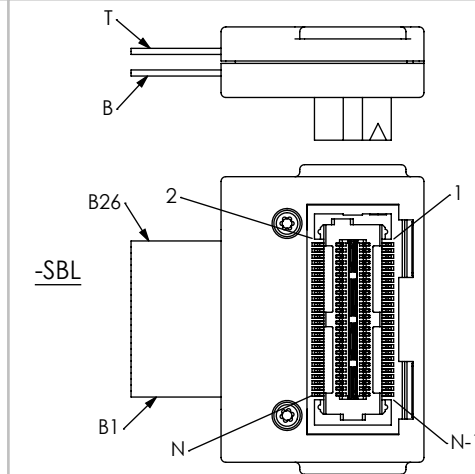

WIRING OPTION	FIRST END PIN #	SECOND END PIN #
1	1	1
2	1	2
3	1	N-1
4	1	N

**PROPRIETARY NOTE**  
 THIS DOCUMENT CONTAINS INFORMATION CONFIDENTIAL AND PROPRIETARY TO SAMTEC, INC. AND SHALL NOT BE REPRODUCED OR TRANSFERRED TO OTHER DOCUMENTS OR DISCLOSED TO OTHERS OR USED FOR ANY PURPOSE OTHER THAN THAT WHICH IT WAS OBTAINED WITHOUT THE EXPRESSED WRITTEN CONSENT OF SAMTEC, INC.

DO NOT SCALE DRAWING  
 SHEET SCALE: 1:25:1



520 PARK EAST BLVD, NEW ALBANY, IN 47150  
 PHONE: 812-944-6733 FAX: 812-948-5047  
 e-Mail: info@SAMTEC.com code: 53322

DESCRIPTION:  
 .635mm HIGH-SPEED COAX CABLE ASSEMBLY  
 DWG. NO.  
 6QCD-XXX-XX.XX-XXX-XXX-X-X  
 BY: D. FRALEY 03/14/2006 SHEET 3 OF 7

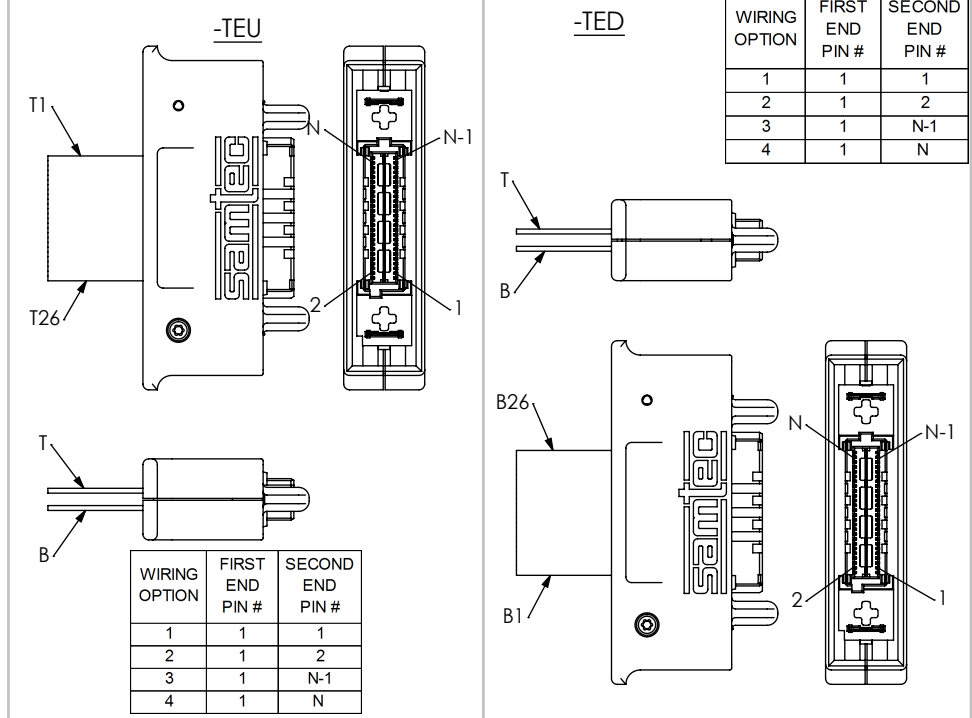
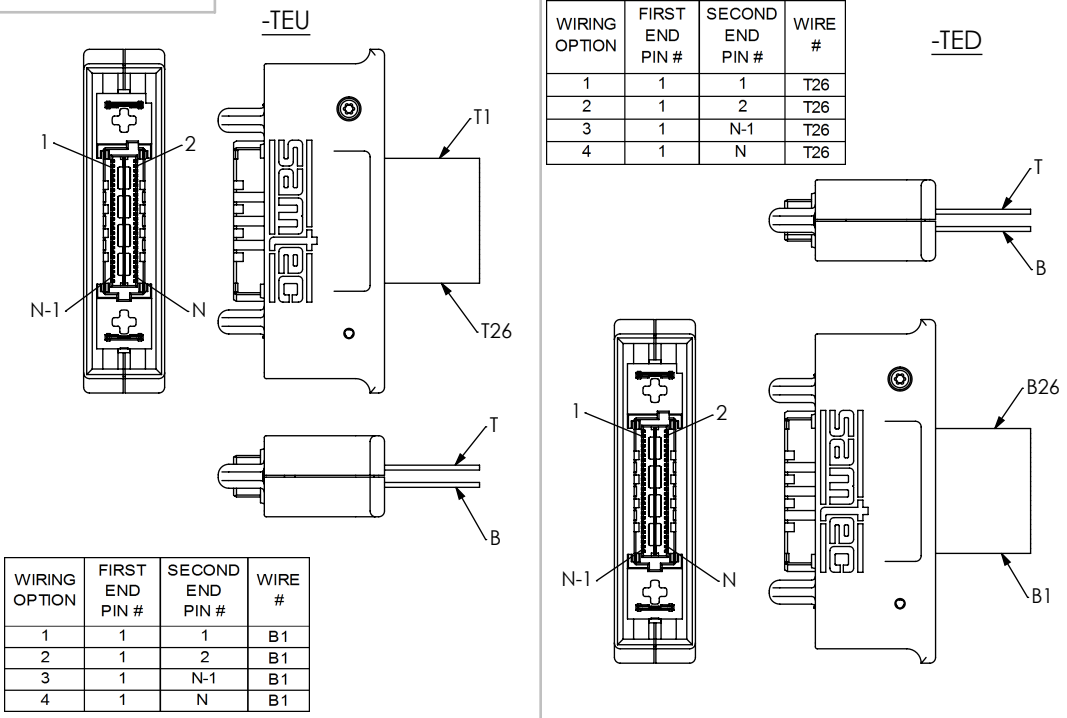

**FIG 2**  
EDGE MOUNT (NO CAPTIVE PANEL SCREWS)  
(6QCD-026-XX.XX-TEU-STL-X SHOWN)  
(SAME AS FIG 1, UNLESS OTHERWISE STATED)

No. OF POSITIONS	"D"	"E"	QDP-XX-03	SUB-6QCD-X-XXX-03-XX
-026	1.790 [45.47]	1.640 [41.66]	QDP-01-03	SUB-6QCD-X-026-03-XX
-052	2.630 [66.80]	2.480 [62.99]	QDP-02-03	SUB-6QCD-X-052-03-XX
-078	3.470 [88.14]	3.320 [84.33]	QDP-03-03	SUB-6QCD-X-078-03-XX
-104	4.310 [109.47]	4.160 [105.66]	QDP-04-03	SUB-6QCD-X-104-03-XX

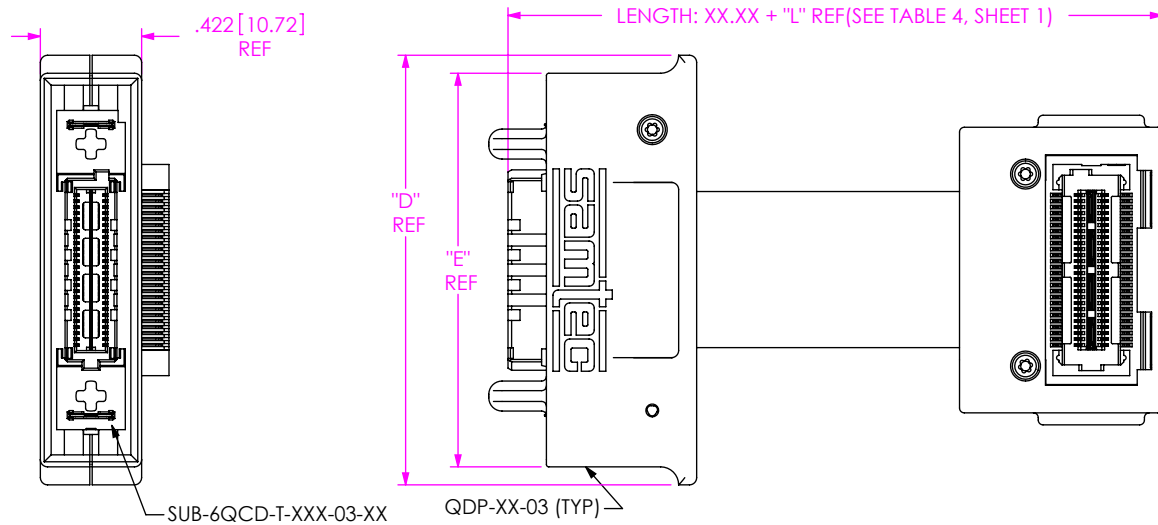

c:\enterprisevault\DWG\MISC\MKTG\6QCD-XXX-XX.XX-XXX-XXX-X-MKT.SLDDRW

**PROPRIETARY NOTE**  
 THIS DOCUMENT CONTAINS INFORMATION CONFIDENTIAL AND PROPRIETARY TO SAMTEC, INC. AND SHALL NOT BE REPRODUCED OR TRANSFERRED TO OTHER DOCUMENTS OR DISCLOSED TO OTHERS OR USED FOR ANY PURPOSE OTHER THAN THAT WHICH IT WAS OBTAINED WITHOUT THE EXPRESSED WRITTEN CONSENT OF SAMTEC, INC.

DO NOT SCALE DRAWING  
 SHEET SCALE: 1:1

**samtec**  
 520 PARK EAST BLVD, NEW ALBANY, IN 47150  
 PHONE: 812-944-6733 FAX: 812-948-5047  
 e-Mail: info@SAMTEC.com code: 55322

DESCRIPTION:  
 .635mm HIGH-SPEED COAX CABLE ASSEMBLY  
 DWG. NO.  
 6QCD-XXX-XX.XX-XXX-XXX-X-X  
 BY: D. FRALEY 03/14/2006 SHEET 4 OF 7

FIRST END - EDGE MOUNT (SEE TABLE 9, SHEET 7)

SECOND END - EDGE MOUNT (SEE TABLE 9, SHEET 7)

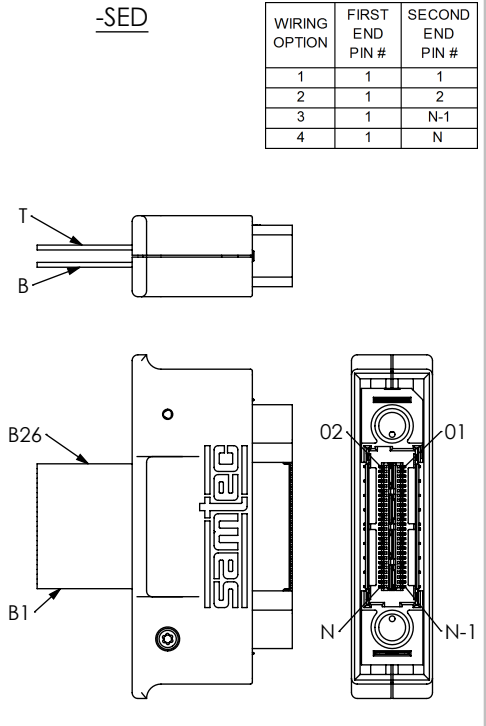
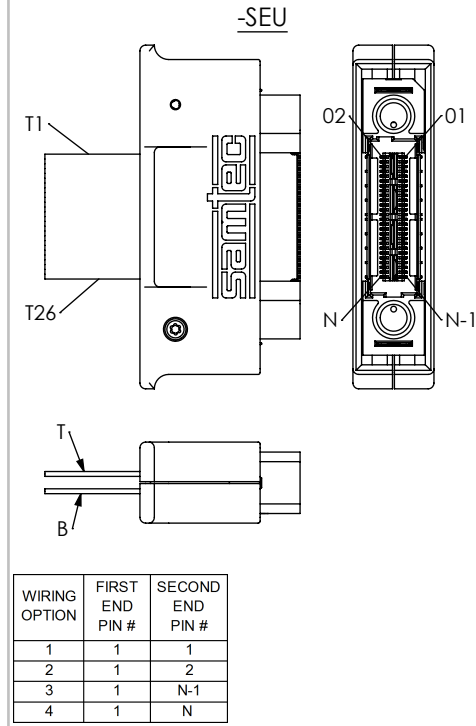
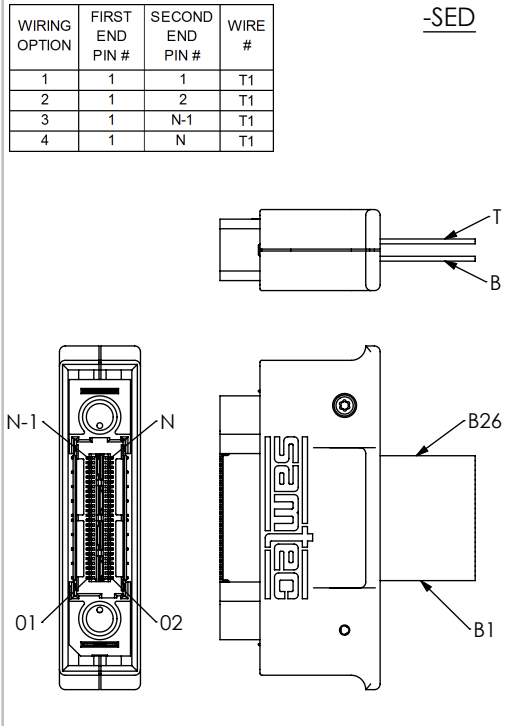
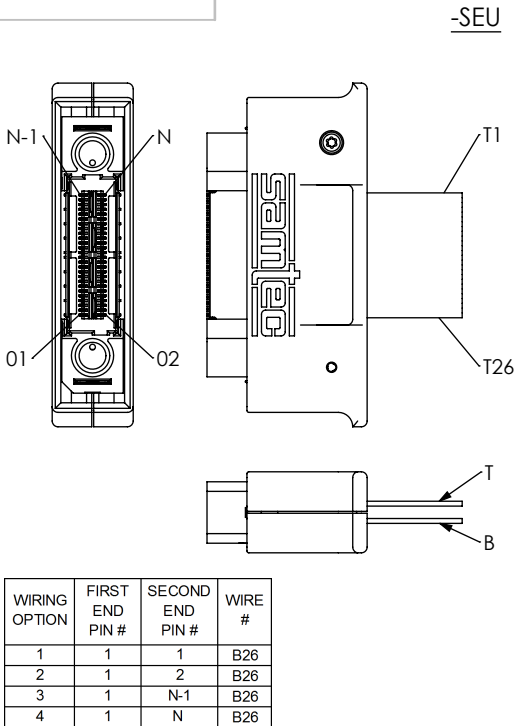
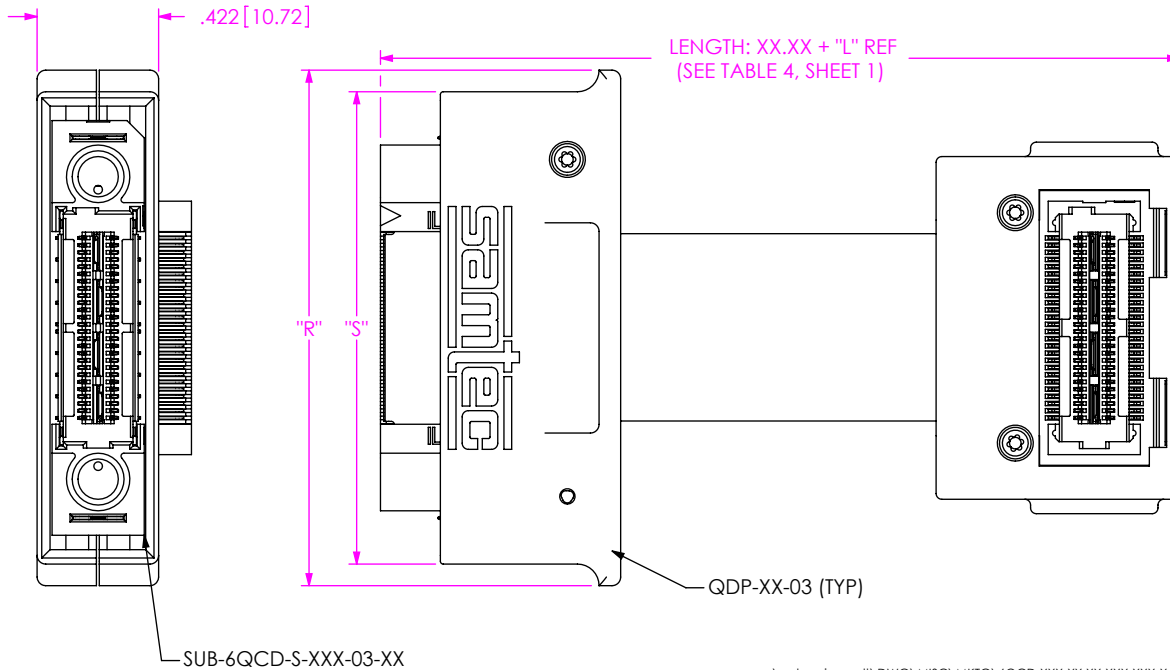

FIG 2A  
EDGE MOUNT (NO CAPTIVE PANEL SCREWS)  
(6QCD-026-XX.XX-SED-STL-X SHOWN)  
(SAME AS FIG 1, UNLESS OTHERWISE STATED)



**TABLE 11**

No. OF POSITIONS	"R"	"S"	QDP-XX-03	SUB-6QCD-X-XXX-03-XX
-026	1.790 [45.47]	1.640 [41.66]	QDP-01-03	SUB-6QCD-X-026-03-XX
-052	2.630 [66.80]	2.480 [62.99]	QDP-02-03	SUB-6QCD-X-052-03-XX
-078	3.470 [88.14]	3.320 [84.33]	QDP-03-03	SUB-6QCD-X-078-03-XX
-104	4.310 [109.47]	4.160 [105.66]	QDP-04-03	SUB-6QCD-X-104-03-XX

**PROPRIETARY NOTE**  
THIS DOCUMENT CONTAINS INFORMATION CONFIDENTIAL AND PROPRIETARY TO SAMTEC, INC. AND SHALL NOT BE REPRODUCED OR TRANSFERRED TO OTHER DOCUMENTS OR DISCLOSED TO OTHERS OR USED FOR ANY PURPOSE OTHER THAN THAT WHICH IT WAS OBTAINED WITHOUT THE EXPRESSED WRITTEN CONSENT OF SAMTEC, INC.



520 PARK EAST BLVD, NEW ALBANY, IN 47150  
PHONE: 812-944-6733 FAX: 812-948-5047  
e-Mail: info@SAMTEC.com code: 55322

DO NOT SCALE DRAWING  
SHEET SCALE: 1:1

DESCRIPTION:  
.635mm HIGH-SPEED COAX CABLE ASSEMBLY  
DWG. NO.  
**6QCD-XXX-XX.XX-XXX-XXX-X-X**  
BY: D. FRALEY 03/14/2006 SHEET 5 OF 7

**FIG 3**  
EDGE MOUNT (WITH CAPTIVE PANEL SCREWS)  
(6QCD-026-XX.XX-TEU-XXX-1-F SHOWN)  
(SAME AS FIG 2, UNLESS OTHERWISE STATED)

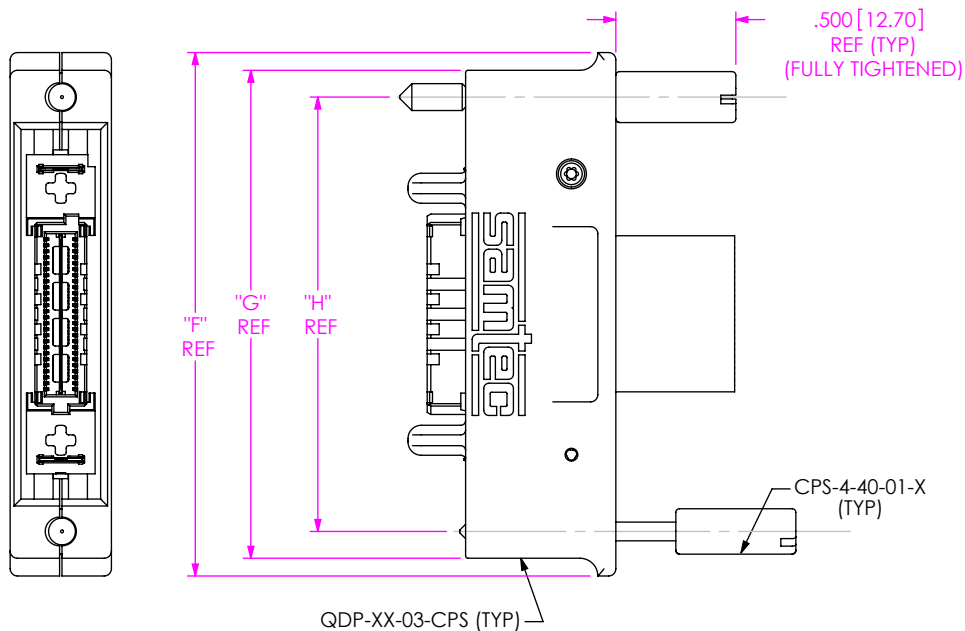

No. OF POSITIONS	"F"	"G"	"H"	QDP-XX-03-CPS
-026	2.181 [55.40]	2.033 [51.64]	1.8099 [45.97]	QDP-01-03-CPS
-052	3.021 [76.73]	2.873 [72.97]	2.6499 [67.31]	QDP-02-03-CPS
-078	3.861 [98.07]	3.713 [94.31]	3.4899 [88.64]	QDP-03-03-CPS
-104	4.701 [119.41]	4.553 [115.65]	4.3299 [109.98]	QDP-04-03-CPS

**FIG 4**  
DOUBLE VERTICAL (WITH SCREW DOWN OPTION)  
(6QCD-026-XX.XX-STR-XXX-1-F SHOWN)  
(SAME AS FIG 1, UNLESS OTHERWISE STATED)

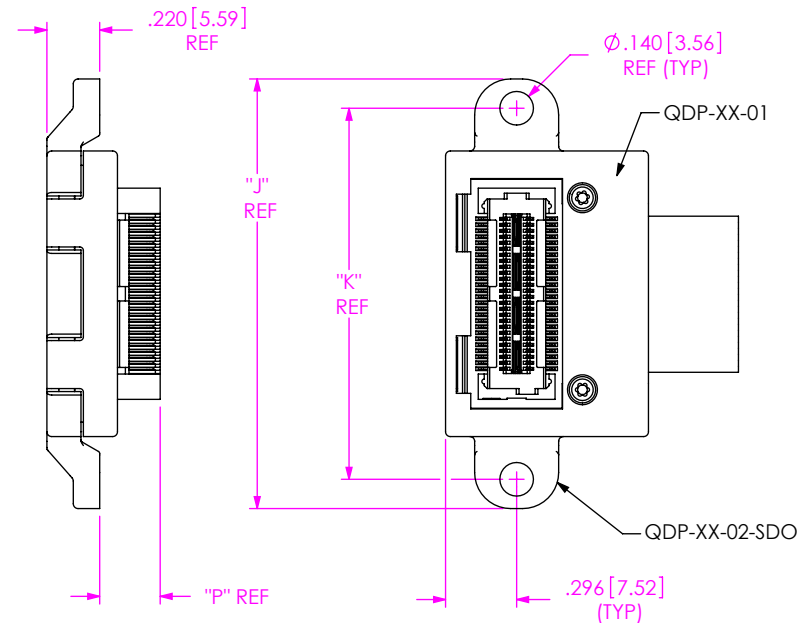

No. OF POSITIONS	"J"	"K"	QDP-XX-02-SDO
-026	1.790 [45.47]	1.546 [39.27]	QDP-01-02-SDO
-052	2.630 [66.80]	2.386 [60.60]	QDP-02-02-SDO
-078	3.470 [88.14]	3.226 [81.94]	QDP-03-02-SDO
-104	4.310 [109.47]	4.066 [103.28]	QDP-04-02-SDO

END	"P"
-TXX	0.224 [5.69]
-SXX	0.252 [6.40]

**FIG 5**  
(6QCD-026-XX.XX-TEU-STL-X-N SHOWN)  
(SAME AS FIG 1, UNLESS OTHERWISE STATED)  
SOLDER SPLATTER VISIBLE AT 0X MAGNIFICATION  
TO BE WICKED OFF EXPOSED GOLD SURFACES ON -N PARTS

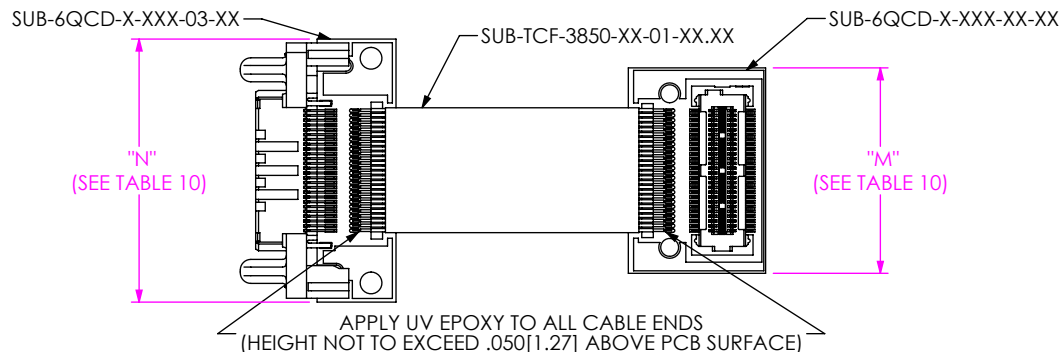

No OF POSITIONS	"M"	"N"
-026	1.070[27.18]	1.370[34.80]
-052	1.910[48.51]	2.210[56.13]
-078	2.750[69.85]	3.050[77.47]
-104	3.590[91.19]	3.890[98.81]

**PROPRIETARY NOTE**  
THIS DOCUMENT CONTAINS INFORMATION  
CONFIDENTIAL AND PROPRIETARY TO  
SAMTEC, INC. AND SHALL NOT BE REPRODUCED  
OR TRANSFERRED TO OTHER DOCUMENTS OR  
DISCLOSED TO OTHERS OR USED FOR ANY  
PURPOSE OTHER THAN THAT WHICH IT WAS  
OBTAINED WITHOUT THE EXPRESSED WRITTEN  
CONSENT OF SAMTEC, INC.

DO NOT SCALE DRAWING

SHEET SCALE: 1:25:1



520 PARK EAST BLVD, NEW ALBANY, IN 47150  
PHONE: 812-944-6733 FAX: 812-948-5047  
e-Mail: info@SAMTEC.com code: 53322

DESCRIPTION:  
.635mm HIGH-SPEED COAX CABLE ASSEMBLY

DWG. NO.  
6QCD-XXX-XX.XX-XXX-XXX-X-X

BY: D. FRALEY 03/14/2006 SHEET 6 OF 7

TABLE 9

FIRST END OPTION	FIRST END SUB-6QCD- X-XXX-XX-01	WIRING OPTION	FIRST END PIN #	SECOND END PIN #	WIRE #	SECOND END OPTION (SUB-6QCD-X-XXX-XX-XX)											
						-TTR	-TTL	-TBR	-TBL	-STR	-STL	-SBR	-SBL	-TEU	-TED	-SEU	-SED
-TTR	-T-XXX-01-01	1	1	1	B1	-T-XXX-02-02	N/A	N/A	-T-XXX-01-02	N/A	-S-XXX-01-01	-S-XXX-02-01	N/A	N/A	-T-XXX-03-02	-S-XXX-03-01	N/A
		2	1	2	B1	-T-XXX-02-01	N/A	N/A	-T-XXX-01-01	N/A	-S-XXX-01-02	-S-XXX-02-02	N/A	N/A	-T-XXX-03-01	-S-XXX-03-02	N/A
		3	1	N-1	B1	N/A	-T-XXX-01-01	-T-XXX-02-01	N/A	-S-XXX-02-02	N/A	N/A	-S-XXX-01-02	-T-XXX-03-01	N/A	N/A	-S-XXX-03-02
		4	1	N	B1	N/A	-T-XXX-01-02	-T-XXX-02-02	N/A	-S-XXX-02-01	N/A	N/A	-S-XXX-01-01	-T-XXX-03-02	N/A	N/A	-S-XXX-03-01
-TTL	-T-XXX-02-01	1	1	1	T26	N/A	-T-XXX-01-02	-T-XXX-02-02	N/A	-S-XXX-02-01	N/A	N/A	-S-XXX-01-01	-T-XXX-03-02	N/A	N/A	-S-XXX-03-01
		2	1	2	T26	N/A	-T-XXX-01-01	-T-XXX-02-01	N/A	-S-XXX-02-02	N/A	N/A	-S-XXX-01-02	-T-XXX-03-01	N/A	N/A	-S-XXX-03-02
		3	1	N-1	T26	-T-XXX-02-01	N/A	N/A	-T-XXX-01-01	N/A	-S-XXX-01-02	-S-XXX-02-02	N/A	N/A	-T-XXX-03-01	-S-XXX-03-02	N/A
		4	1	N	T26	-T-XXX-02-02	N/A	N/A	-T-XXX-01-02	N/A	-S-XXX-01-01	-S-XXX-02-01	N/A	N/A	-T-XXX-03-02	-S-XXX-03-01	N/A
-TBR	-T-XXX-01-01	1	1	1	T26	N/A	-T-XXX-01-02	-T-XXX-02-02	N/A	-S-XXX-02-01	N/A	N/A	-S-XXX-01-01	-T-XXX-03-02	N/A	N/A	-S-XXX-03-01
		2	1	2	T26	N/A	-T-XXX-01-01	-T-XXX-02-01	N/A	-S-XXX-02-02	N/A	N/A	-S-XXX-01-02	-T-XXX-03-01	N/A	N/A	-S-XXX-03-02
		3	1	N-1	T26	-T-XXX-02-01	N/A	N/A	-T-XXX-01-01	N/A	-S-XXX-01-02	-S-XXX-02-02	N/A	N/A	-T-XXX-03-01	-S-XXX-03-02	N/A
		4	1	N	T26	-T-XXX-02-02	N/A	N/A	-T-XXX-01-02	N/A	-S-XXX-01-01	-S-XXX-02-01	N/A	N/A	-T-XXX-03-02	-S-XXX-03-01	N/A
-TBL	-T-XXX-02-01	1	1	1	B1	-T-XXX-02-02	N/A	N/A	-T-XXX-01-02	N/A	-S-XXX-01-01	-S-XXX-02-01	N/A	N/A	-T-XXX-03-02	-S-XXX-03-01	N/A
		2	1	2	B1	-T-XXX-02-01	N/A	N/A	-T-XXX-01-01	N/A	-S-XXX-01-02	-S-XXX-02-02	N/A	N/A	-T-XXX-03-01	-S-XXX-03-02	N/A
		3	1	N-1	B1	N/A	-T-XXX-01-01	-T-XXX-02-01	N/A	-S-XXX-02-02	N/A	N/A	-S-XXX-01-02	-T-XXX-03-01	N/A	N/A	-S-XXX-03-02
		4	1	N	B1	N/A	-T-XXX-01-02	-T-XXX-02-02	N/A	-S-XXX-02-01	N/A	N/A	-S-XXX-01-01	-T-XXX-03-02	N/A	N/A	-S-XXX-03-01
-STR	-S-XXX-01-01	1	1	1	B26	N/A	-T-XXX-01-01	-T-XXX-02-01	N/A	-S-XXX-02-02	N/A	N/A	-S-XXX-01-02	-T-XXX-03-01	N/A	N/A	-S-XXX-03-02
		2	1	2	B26	N/A	-T-XXX-01-02	-T-XXX-02-02	N/A	-S-XXX-02-01	N/A	N/A	-S-XXX-01-01	-T-XXX-03-02	N/A	N/A	-S-XXX-03-01
		3	1	N-1	B26	-T-XXX-02-02	N/A	N/A	-T-XXX-01-02	N/A	-S-XXX-01-01	-S-XXX-02-01	N/A	N/A	-T-XXX-03-01	-S-XXX-03-02	N/A
		4	1	N	B26	-T-XXX-02-01	N/A	N/A	-T-XXX-01-01	N/A	-S-XXX-01-02	-S-XXX-02-02	N/A	N/A	-T-XXX-03-02	-S-XXX-03-01	N/A
-STL	-S-XXX-02-01	1	1	1	T1	-T-XXX-02-01	N/A	N/A	-T-XXX-01-01	N/A	-S-XXX-01-02	-S-XXX-02-02	N/A	N/A	-T-XXX-03-01	-S-XXX-03-02	N/A
		2	1	2	T1	-T-XXX-02-02	N/A	N/A	-T-XXX-01-02	N/A	-S-XXX-01-01	-S-XXX-02-01	N/A	N/A	-T-XXX-03-02	-S-XXX-03-01	N/A
		3	1	N-1	T1	N/A	-T-XXX-01-02	-T-XXX-02-02	N/A	-S-XXX-02-01	N/A	N/A	-S-XXX-01-01	-T-XXX-03-01	N/A	N/A	-S-XXX-03-02
		4	1	N	T1	N/A	-T-XXX-01-01	-T-XXX-02-01	N/A	-S-XXX-02-02	N/A	N/A	-S-XXX-01-02	-T-XXX-03-02	N/A	N/A	-S-XXX-03-01
-SBR	-S-XXX-01-01	1	1	1	T1	-T-XXX-02-01	N/A	N/A	-T-XXX-01-01	N/A	-S-XXX-01-02	-S-XXX-02-02	N/A	N/A	-T-XXX-03-01	-S-XXX-03-02	N/A
		2	1	2	T1	-T-XXX-02-02	N/A	N/A	-T-XXX-01-02	N/A	-S-XXX-01-01	-S-XXX-02-01	N/A	N/A	-T-XXX-03-02	-S-XXX-03-01	N/A
		3	1	N-1	T1	N/A	-T-XXX-01-02	-T-XXX-02-02	N/A	-S-XXX-02-01	N/A	N/A	-S-XXX-01-01	-T-XXX-03-01	N/A	N/A	-S-XXX-03-02
		4	1	N	T1	N/A	-T-XXX-01-01	-T-XXX-02-01	N/A	-S-XXX-02-02	N/A	N/A	-S-XXX-01-02	-T-XXX-03-02	N/A	N/A	-S-XXX-03-01
-SBL	-S-XXX-02-01	1	1	1	B26	N/A	-T-XXX-01-01	-T-XXX-02-01	N/A	-S-XXX-02-02	N/A	N/A	-S-XXX-01-02	-T-XXX-03-01	N/A	N/A	-S-XXX-03-02
		2	1	2	B26	N/A	-T-XXX-01-02	-T-XXX-02-02	N/A	-S-XXX-02-01	N/A	N/A	-S-XXX-01-01	-T-XXX-03-02	N/A	N/A	-S-XXX-03-01
		3	1	N-1	B26	-T-XXX-02-02	N/A	N/A	-T-XXX-01-02	N/A	-S-XXX-01-01	-S-XXX-02-01	N/A	N/A	-T-XXX-03-01	-S-XXX-03-02	N/A
		4	1	N	B26	-T-XXX-02-01	N/A	N/A	-T-XXX-01-01	N/A	-S-XXX-01-02	-S-XXX-02-02	N/A	N/A	-T-XXX-03-02	-S-XXX-03-01	N/A
-TEU	-T-XXX-03-01	1	1	1	B1	-T-XXX-02-02	N/A	N/A	-T-XXX-01-02	N/A	-S-XXX-01-01	-S-XXX-02-01	N/A	N/A	-T-XXX-03-02	-S-XXX-03-01	N/A
		2	1	2	B1	-T-XXX-02-01	N/A	N/A	-T-XXX-01-01	N/A	-S-XXX-01-02	-S-XXX-02-02	N/A	N/A	-T-XXX-03-01	-S-XXX-03-02	N/A
		3	1	N-1	B1	N/A	-T-XXX-01-01	-T-XXX-02-01	N/A	-S-XXX-02-02	N/A	N/A	-S-XXX-01-02	-T-XXX-03-01	N/A	N/A	-S-XXX-03-02
		4	1	N	B1	N/A	-T-XXX-01-02	-T-XXX-02-02	N/A	-S-XXX-02-01	N/A	N/A	-S-XXX-01-01	-T-XXX-03-02	N/A	N/A	-S-XXX-03-01
-TED	-T-XXX-03-01	1	1	1	T26	N/A	-T-XXX-01-02	-T-XXX-02-02	N/A	-S-XXX-02-01	N/A	N/A	-S-XXX-01-01	-T-XXX-03-02	N/A	N/A	-S-XXX-03-01
		2	1	2	T26	N/A	-T-XXX-01-01	-T-XXX-02-01	N/A	-S-XXX-02-02	N/A	N/A	-S-XXX-01-02	-T-XXX-03-01	N/A	N/A	-S-XXX-03-02
		3	1	N-1	T26	-T-XXX-02-01	N/A	N/A	-T-XXX-01-01	N/A	-S-XXX-01-02	-S-XXX-02-02	N/A	N/A	-T-XXX-03-01	-S-XXX-03-02	N/A
		4	1	N	T26	-T-XXX-02-02	N/A	N/A	-T-XXX-01-02	N/A	-S-XXX-01-01	-S-XXX-02-01	N/A	N/A	-T-XXX-03-02	-S-XXX-03-01	N/A
-SEU	-S-XXX-03-01	1	1	1	B26	N/A	-T-XXX-01-01	-T-XXX-02-01	N/A	-S-XXX-02-02	N/A	N/A	-S-XXX-01-02	-T-XXX-03-01	N/A	N/A	-S-XXX-03-02
		2	1	2	B26	N/A	-T-XXX-01-02	-T-XXX-02-02	N/A	-S-XXX-02-01	N/A	N/A	-S-XXX-01-01	-T-XXX-03-02	N/A	N/A	-S-XXX-03-01
		3	1	N-1	B26	-T-XXX-02-02	N/A	N/A	-T-XXX-01-02	N/A	-S-XXX-01-01	-S-XXX-02-01	N/A	N/A	-T-XXX-03-01	-S-XXX-03-02	N/A
		4	1	N	B26	-T-XXX-02-01	N/A	N/A	-T-XXX-01-01	N/A	-S-XXX-01-02	-S-XXX-02-02	N/A	N/A	-T-XXX-03-02	-S-XXX-03-01	N/A
-SED	-S-XXX-03-01	1	1	1	T1	-T-XXX-02-01	N/A	N/A	-T-XXX-01-01	N/A	-S-XXX-01-02	-S-XXX-02-02	N/A	N/A	-T-XXX-03-01	-S-XXX-03-02	N/A
		2	1	2	T1	-T-XXX-02-02	N/A	N/A	-T-XXX-01-02	N/A	-S-XXX-01-01	-S-XXX-02-01	N/A	N/A	-T-XXX-03-02	-S-XXX-03-01	N/A
		3	1	N-1	T1	N/A	-T-XXX-01-02	-T-XXX-02-02	N/A	-S-XXX-02-01	N/A	N/A	-S-XXX-01-01	-T-XXX-03-01	N/A	N/A	-S-XXX-03-02
		4	1	N	T1	N/A	-T-XXX-01-01	-T-XXX-02-01	N/A	-S-XXX-02-02	N/A	N/A	-S-XXX-01-02	-T-XXX-03-02	N/A	N/A	-S-XXX-03-01

**PROPRIETARY NOTE**  
 THIS DOCUMENT CONTAINS INFORMATION CONFIDENTIAL AND PROPRIETARY TO SAMTEC, INC. AND SHALL NOT BE REPRODUCED OR TRANSFERRED TO OTHER DOCUMENTS OR DISCLOSED TO OTHERS OR USED FOR ANY PURPOSE OTHER THAN THAT WHICH IT WAS OBTAINED WITHOUT THE EXPRESSED WRITTEN CONSENT OF SAMTEC, INC.



520 PARK EAST BLVD, NEW ALBANY, IN 47150  
 PHONE: 812-944-6733 FAX: 812-948-5047  
 e-Mail: info@SAMTEC.com code: 55322

DO NOT SCALE DRAWING

DESCRIPTION:  
 .635mm HIGH-SPEED COAX CABLE ASSEMBLY

DWG. NO.  
 6QCD-XXX-XX.XX-XXX-XXX-X-X

SHEET SCALE: 1:25:1

BY: D. FRALEY 03/14/2006 SHEET 7 OF 7