

THIS PRODUCT MANUFACTURED WITH LEAD-FREE PROCESSING

FIG 1 VERTICAL
(HQDP-040-XX.XX-STR-STR-5 SHOWN)

HQDP-XXX-XX.XX-XXX-XXX-X-X

DO NOT SCALE FROM THIS PRINT

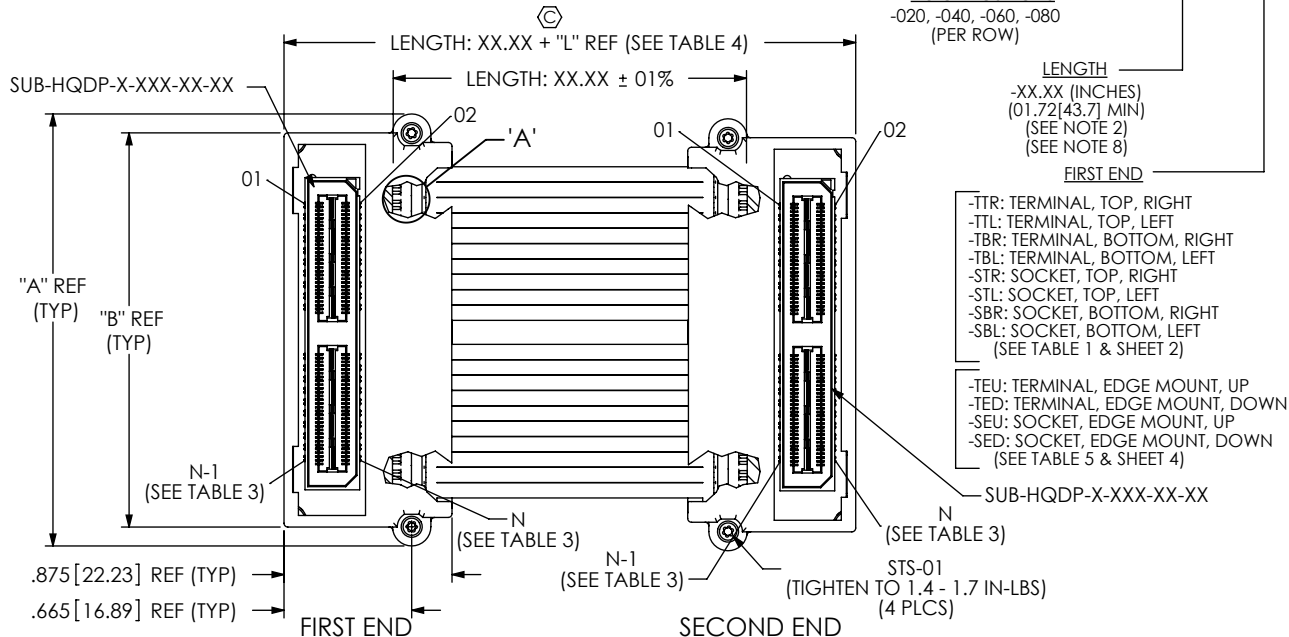

No OF POSITIONS
-020, -040, -060, -080
(PER ROW)

LENGTH
-XX.XX (INCHES)
(01.72[43.7] MIN)
(SEE NOTE 2)
(SEE NOTE 8)

- FIRST END**
- TR: TERMINAL, TOP, RIGHT
 - TL: TERMINAL, TOP, LEFT
 - BR: TERMINAL, BOTTOM, RIGHT
 - BL: TERMINAL, BOTTOM, LEFT
 - STR: SOCKET, TOP, RIGHT
 - STL: SOCKET, TOP, LEFT
 - SBR: SOCKET, BOTTOM, RIGHT
 - SBL: SOCKET, BOTTOM, LEFT
 - (SEE TABLE 1 & SHEET 2)
 - TEU: TERMINAL, EDGE MOUNT, UP
 - TED: TERMINAL, EDGE MOUNT, DOWN
 - SEU: SOCKET, EDGE MOUNT, UP
 - SED: SOCKET, EDGE MOUNT, DOWN
 - (SEE TABLE 5 & SHEET 4)

- END OPTION**
- F: SCREW OPTION FIRST END ONLY
 - S: SCREW OPTION SECOND END ONLY
 - B: SCREW OPTION BOTH ENDS
 - L: FIRST END RT1 OPTION (SEE FIG 6, SHT 6)
(SEE NOTE 9 & 10)
 - R: SECOND END RT1 OPTION (SEE FIG 6, SHT 6)
(SEE NOTE 9 & 10)
 - D: BOTH ENDS RT1 OPTION (SEE FIG 6, SHT 6)
(SEE NOTE 9 & 10)
 - 1: FIRST SCREW OPTION,
SECOND END RT1 OPTION (SEE FIG 6, SHT 6)
(SEE NOTE 9 & 10)
 - 2: FIRST END RT1 OPTION,
SECOND END SCREW OPTION (SEE FIG 6, SHT 6)
(SEE NOTE 9 & 10)
 - N: NO CAPS
(SEE FIG 3, SHEET 5 FOR EDGE MOUNT
END OPTIONS)
(SEE FIG 4, SHEET 5 FOR DOUBLE
VERTICAL END OPTIONS)
(SEE FIG 5, SHEET 5 FOR NO CAPS OPTIONS)
(LEAVE BLANK FOR STANDARD CAPS
BOTH ENDS)

- SECOND END**
- TR: TERMINAL, TOP, RIGHT
 - TL: TERMINAL, TOP, LEFT
 - BR: TERMINAL, BOTTOM, RIGHT
 - BL: TERMINAL, BOTTOM, LEFT
 - STR: SOCKET, TOP, RIGHT
 - STL: SOCKET, TOP, LEFT
 - SBR: SOCKET, BOTTOM, RIGHT
 - SBL: SOCKET, BOTTOM, LEFT
 - (SEE TABLE 1 & SHEET 3)
 - TEU: TERMINAL, EDGE MOUNT, UP
 - TED: TERMINAL, EDGE MOUNT, DOWN
 - SEU: SOCKET, EDGE MOUNT, UP
 - SED: SOCKET, EDGE MOUNT, DOWN
 - (SEE TABLE 5 & SHEET 4)
- WIRING OPTION**
(SEE NOTE 13)
- **1: PIN 1 TO PIN 1
 - **2: PIN 1 TO PIN 2
 - **3: PIN 1 TO PIN N-1
 - **4: PIN 1 TO PIN N
 - 5: PIN 1 TO PIN 1
 - 6: PIN 1 TO PIN 2
 - 7: PIN 1 TO PIN N-1
 - 8: PIN 1 TO PIN N
 - (SEE TABLE 9, SHEET 7)

TABLE 3

No. OF POSITIONS	N	N-1
-020	40	39
-040	80	79
-060	120	119
-080	160	159

TABLE 1

No. OF POSITIONS	WIRING OPTION	"A"	"B"	HQDP-XX-01	HQDP-XX-02	QTY OF SUB-TTF	SUB-HQDP-X-XXX-XX-XX	SUB-TTF-30100XX-XX-XX-XX
-020	**1, **2, **3, **4	1.325[33.66]	1.128[28.65]	HQDP-01-01	HQDP-01-02	2	SUB-HQDP-X-020-XX-XX	SUB-TTF-30100-XX-01-XX-XX
	-5, -6, -7, -8	1.325[33.66]	1.128[28.65]	HQDP-01-01	HQDP-01-02	2	SUB-HQDP-X-020-XX-XX	SUB-TTF-30100CU-XX-01-XX-XX
-040	**1, **2, **3, **4	2.250[57.15]	2.053[52.15]	HQDP-02-01	HQDP-02-02	4	SUB-HQDP-X-040-XX-XX	SUB-TTF-30100-XX-01-XX-XX
	-5, -6, -7, -8	2.250[57.15]	2.053[52.15]	HQDP-02-01	HQDP-02-02	4	SUB-HQDP-X-040-XX-XX	SUB-TTF-30100CU-XX-01-XX-XX
-060	**1, **2, **3, **4	3.175[80.65]	2.978[75.64]	HQDP-03-01	HQDP-03-02	6	SUB-HQDP-X-060-XX-XX	SUB-TTF-30100-XX-01-XX-XX
	-5, -6, -7, -8	3.175[80.65]	2.978[75.64]	HQDP-03-01	HQDP-03-02	6	SUB-HQDP-X-060-XX-XX	SUB-TTF-30100CU-XX-01-XX-XX
-080	**1, **2, **3, **4	4.100[104.14]	3.903[99.14]	HQDP-04-01	HQDP-04-02	8	SUB-HQDP-X-080-XX-XX	SUB-TTF-30100-XX-01-XX-XX
	-5, -6, -7, -8	4.100[104.14]	3.903[99.14]	HQDP-04-01	HQDP-04-02	8	SUB-HQDP-X-080-XX-XX	SUB-TTF-30100CU-XX-01-XX-XX

** : AVAILABLE TO EXISTING CUSTOMERS ONLY

NOTES:

1. REPRESENTS A CRITICAL DIMENSION.
2. SUB-TTF LENGTH IS EQUAL TO HQDP LENGTH.
3. ALL ASSEMBLIES TO BE 100% ELECTRICALLY TESTED FOR SHORTS AND OPENS.
4. ALL ASSEMBLIES TO BE 100% HI-POT TESTED AT 300V.
5. TOP SUB-TTF NOT SHOWN IN THIS VIEW FOR CLARITY; HDRL-11 IS TO BE CENTERED ON LOWER SUB-TTF AS SHOWN; HDRL-11 IS TO CONTAIN PART NUMBER, SHOP NUMBER & DATE CODE.
6. PACKAGE ASSEMBLIES IN STATIC DISSIPATIVE BAGS.
7. PARTS TO BE PROCESSED PER SAMTEC ACCEPTABILITY REQUIREMENTS: HDR-PI-01 "CABLE ASSEMBLY WORKMANSHIP STANDARDS".
8. CABLE LENGTHS LONGER THAN 40.00 INCHES ARE NOT SUPPORTED BY S.I. TEST DATA.
9. RT1 OPTION IS NOT AVAILABLE WITH EDGEMOUNT & PANEL MOUNT END OPTIONS.
10. RT1 OPTION IS NOT AVAILABLE WITH -080 PAIRS.
11. DIFFERENTIAL PAIRS CONSIST OF ADJACENT PINS. FOR EXAMPLE, PIN POSITIONS 1 AND 3, 2 AND 4, 5 AND 7, ETC.
12. ALL POSITIONS ARE TRANSMITTED AS SIGNALS ACROSS TWINAX CENTER CONDUCTORS. CONNECTOR GROUND BLADES ARE TIED TO TWINAX SHIELD. FOR MULTIPLE BANK ASSEMBLIES, EACH BANK IS GROUND INDEPENDENT OF THE OTHERS.
13. WIRING OPTION -5 THROUGH -8 USE 30100CU.

TABLE 4

END TO END	"L"
DV TO DV	1.150[28.21]
DV TO EM (-TEX)	1.065[27.05]
DV TO EM (-SEX)	1.036[26.31]
EM (-TEX) TO EM (-TEX)	.980[24.89]
EM (-TEX) TO EM (-SEX)	.951[24.16]
EM (-SEX) TO EM (-SEX)	.922[23.42]
DV-N TO DV-N	1.050[26.67]
DV-N TO EM-N (-TEX)	1.015[25.78]
DV-N TO EM-N (-SEX)	.986[25.04]

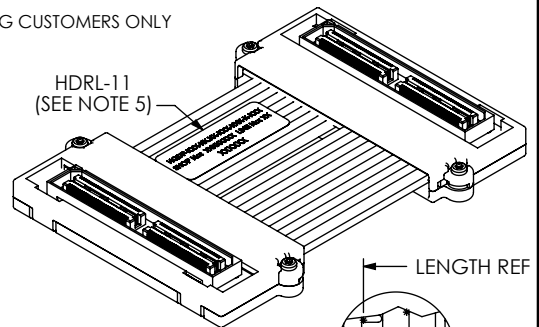

TABLE 2

END	"C"
-TXX	.332[8.43]
-SXX	.296[7.52]

* -DV END OPTIONS ONLY

DETAIL 'A'
SCALE 2.5 : 1

UNLESS OTHERWISE SPECIFIED, DIMENSIONS ARE IN INCHES.
TOLERANCES ARE:
DECIMALS ANGLES
.XX: ±.01 [.3]
.XXX: ±.005 [.13]
.XXXX: ±.0020 [.051]

MATERIAL: DO NOT SCALE DRAWING SHEET SCALE: 1:1

PROPRIETARY NOTE
THIS DOCUMENT CONTAINS CONFIDENTIAL AND PROPRIETARY INFORMATION AND ALL DESIGN, MANUFACTURING, REPRODUCTION, USE, PATENT RIGHTS AND SALES RIGHTS ARE EXPRESSLY RESERVED BY SAMTEC, INC. THIS DOCUMENT SHALL NOT BE DISCLOSED, IN WHOLE OR PART, TO ANY UNAUTHORIZED PERSON OR ENTITY NOR REPRODUCED, TRANSFERRED OR INCORPORATED IN ANY OTHER PROJECT IN ANY MANNER WITHOUT THE EXPRESS WRITTEN CONSENT OF SAMTEC, INC.

samtec

520 PARK EAST BLVD. NEW ALBANY, IN 47150
PHONE: 812-944-6733 FAX: 812-948-5047
e-Mail: info@SAMTEC.com code: 55322

DESCRIPTION:
0.5mm HIGH-SPEED TWIN-AX CABLE ASSEMBLY

DWG. NO.
HQDP-XXX-XX.XX-XXX-XXX-X-X

BY: BRATCHER 11/18/03 SHEET 1 OF 8

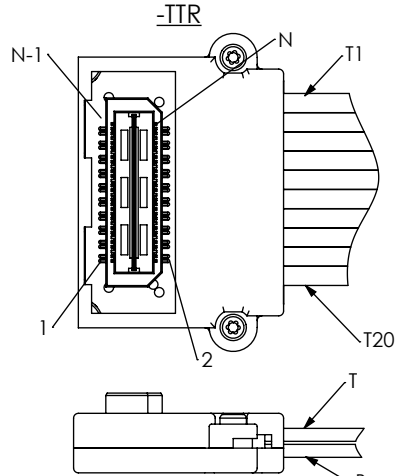

WIRING OPTION	FIRST END PIN #	SECOND END PIN #	WIRE NUMBER
**-1	1	1	B20
**-2	1	2	B20
**-3	1	N-1	B20
**-4	1	N	B20
-5	1	1	B20
-6	1	2	B20
-7	1	N-1	B20
-8	1	N	B20

** : AVAILABLE TO EXISTING CUSTOMERS ONLY

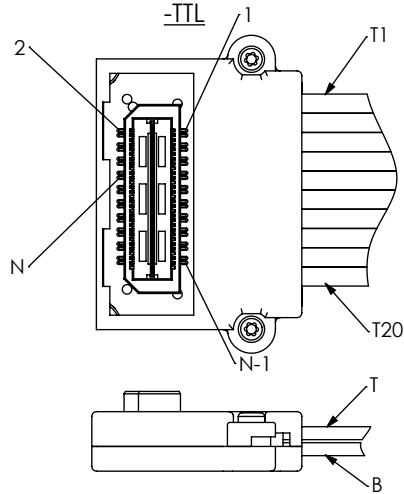

WIRING OPTION	FIRST END PIN #	SECOND END PIN #	WIRE NUMBER
**-1	1	1	T1
**-2	1	2	T1
**-3	1	N-1	T1
**-4	1	N	T1
-5	1	1	T1
-6	1	2	T1
-7	1	N-1	T1
-8	1	N	T1

** : AVAILABLE TO EXISTING CUSTOMERS ONLY

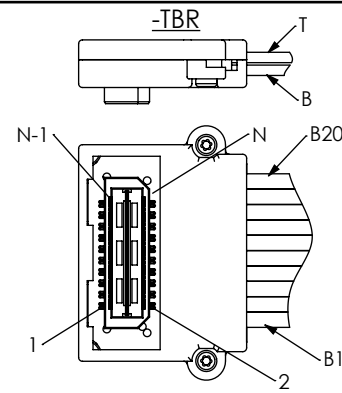

WIRING OPTION	FIRST END PIN #	SECOND END PIN #	WIRE NUMBER
**-1	1	1	T1
**-2	1	2	T1
**-3	1	N-1	T1
**-4	1	N	T1
-5	1	1	T1
-6	1	2	T1
-7	1	N-1	T1
-8	1	N	T1

** : AVAILABLE TO EXISTING CUSTOMERS ONLY

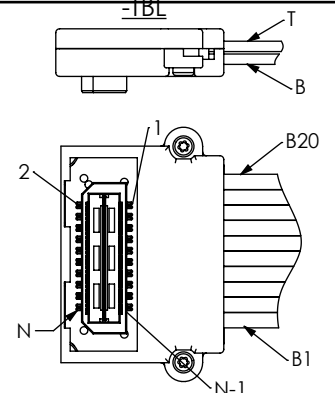

WIRING OPTION	FIRST END PIN #	SECOND END PIN #	WIRE NUMBER
**-1	1	1	B20
**-2	1	2	B20
**-3	1	N-1	B20
**-4	1	N	B20
-5	1	1	B20
-6	1	2	B20
-7	1	N-1	B20
-8	1	N	B20

** : AVAILABLE TO EXISTING CUSTOMERS ONLY

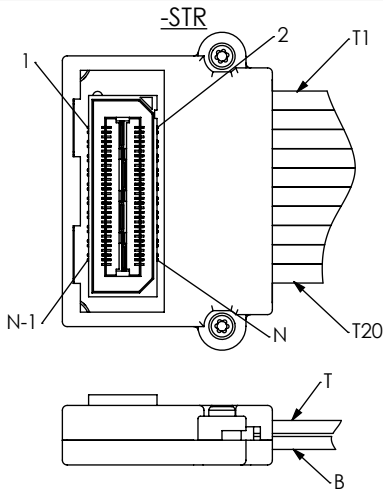

WIRING OPTION	FIRST END PIN #	SECOND END PIN #	WIRE NUMBER
**-1	1	1	B1
**-2	1	2	B1
**-3	1	N-1	B1
**-4	1	N	B1
-5	1	1	B1
-6	1	2	B1
-7	1	N-1	B1
-8	1	N	B1

** : AVAILABLE TO EXISTING CUSTOMERS ONLY

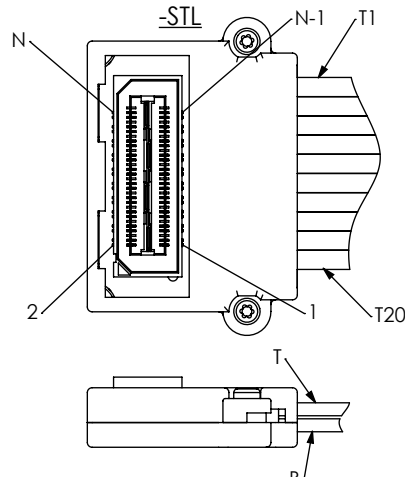

WIRING OPTION	FIRST END PIN #	SECOND END PIN #	WIRE NUMBER
**-1	1	1	T20
**-2	1	2	T20
**-3	1	N-1	T20
**-4	1	N	T20
-5	1	1	T20
-6	1	2	T20
-7	1	N-1	T20
-8	1	N	T20

** : AVAILABLE TO EXISTING CUSTOMERS ONLY

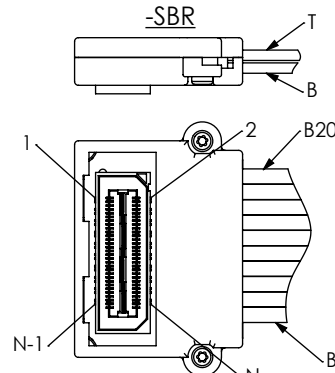

WIRING OPTION	FIRST END PIN #	SECOND END PIN #	WIRE NUMBER
**-1	1	1	T20
**-2	1	2	T20
**-3	1	N-1	T20
**-4	1	N	T20
-5	1	1	T20
-6	1	2	T20
-7	1	N-1	T20
-8	1	N	T20

** : AVAILABLE TO EXISTING CUSTOMERS ONLY

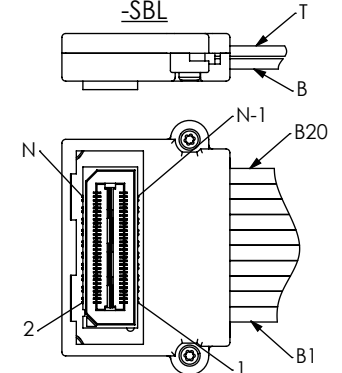

WIRING OPTION	FIRST END PIN #	SECOND END PIN #	WIRE NUMBER
**-1	1	1	B1
**-2	1	2	B1
**-3	1	N-1	B1
**-4	1	N	B1
-5	1	1	B1
-6	1	2	B1
-7	1	N-1	B1
-8	1	N	B1

** : AVAILABLE TO EXISTING CUSTOMERS ONLY

PROPRIETARY NOTE

THIS DOCUMENT CONTAINS CONFIDENTIAL AND PROPRIETARY INFORMATION AND ALL DESIGN, MANUFACTURING, REPRODUCTION, USE, PATENT RIGHTS AND SALES RIGHTS ARE EXPRESSLY RESERVED BY SAMTEC, INC. THIS DOCUMENT SHALL NOT BE DISCLOSED, IN WHOLE OR PART, TO ANY UNAUTHORIZED PERSON OR ENTITY NOR REPRODUCED, TRANSFERRED OR INCORPORATED IN ANY OTHER PROJECT IN ANY MANNER WITHOUT THE EXPRESS WRITTEN CONSENT OF SAMTEC, INC.

DO NOT SCALE DRAWING

SHEET SCALE: 1:25:1



520 PARK EAST BLVD. NEW ALBANY, IN 47150
PHONE: 812-944-6733 FAX: 812-948-5047
e-Mail: info@SAMTEC.com code: 55322

DESCRIPTION:
0.5mm HIGH-SPEED TWIN-AX CABLE ASSEMBLY

DWG. NO.
HQDP-XXX-XX.XX-XXX-XXX-X-X

BY: BRATCHER 11/18/03 SHEET 2 OF 8

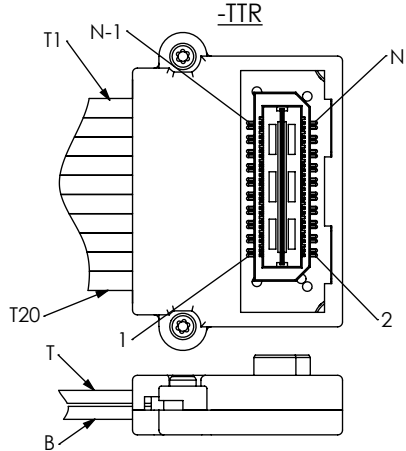

WIRING OPTION	FIRST END PIN #	SECOND END PIN #
**-1	1	1
**-2	1	2
**-3	1	N-1
**-4	1	N
-5	1	1
-6	1	2
-7	1	N-1
-8	1	N

** : AVAILABLE TO EXISTING CUSTOMERS ONLY

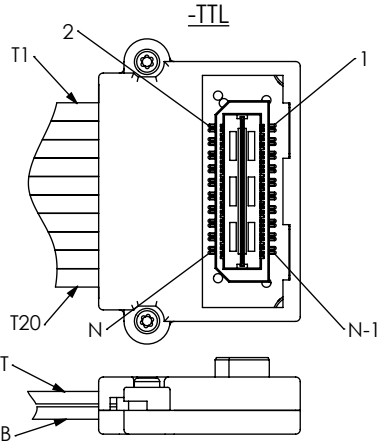

WIRING OPTION	FIRST END PIN #	SECOND END PIN #
**-1	1	1
**-2	1	2
**-3	1	N-1
**-4	1	N
-5	1	1
-6	1	2
-7	1	N-1
-8	1	N

** : AVAILABLE TO EXISTING CUSTOMERS ONLY

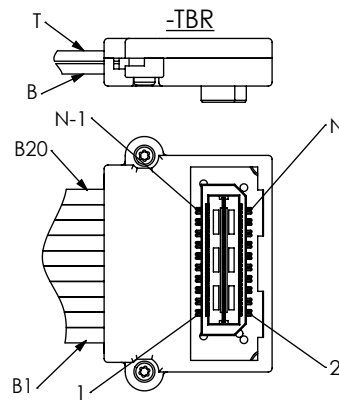

WIRING OPTION	FIRST END PIN #	SECOND END PIN #
**-1	1	1
**-2	1	2
**-3	1	N-1
**-4	1	N
-5	1	1
-6	1	2
-7	1	N-1
-8	1	N

** : AVAILABLE TO EXISTING CUSTOMERS ONLY

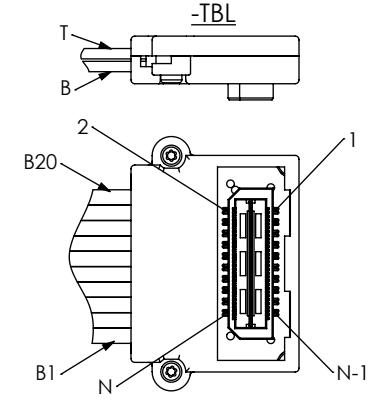

WIRING OPTION	FIRST END PIN #	SECOND END PIN #
**-1	1	1
**-2	1	2
**-3	1	N-1
**-4	1	N
-5	1	1
-6	1	2
-7	1	N-1
-8	1	N

** : AVAILABLE TO EXISTING CUSTOMERS ONLY

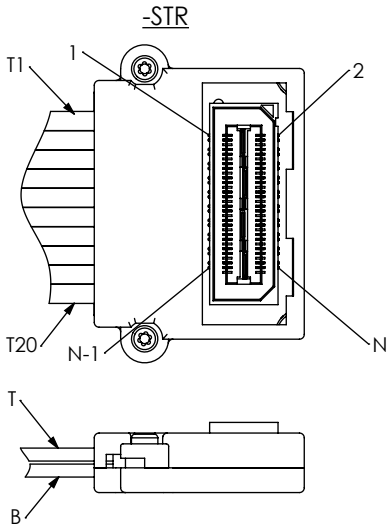

WIRING OPTION	FIRST END PIN #	SECOND END PIN #
**-1	1	1
**-2	1	2
**-3	1	N-1
**-4	1	N
-5	1	1
-6	1	2
-7	1	N-1
-8	1	N

** : AVAILABLE TO EXISTING CUSTOMERS ONLY

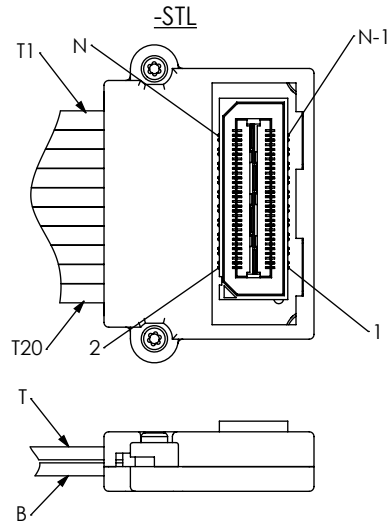

WIRING OPTION	FIRST END PIN #	SECOND END PIN #
**-1	1	1
**-2	1	2
**-3	1	N-1
**-4	1	N
-5	1	1
-6	1	2
-7	1	N-1
-8	1	N

** : AVAILABLE TO EXISTING CUSTOMERS ONLY

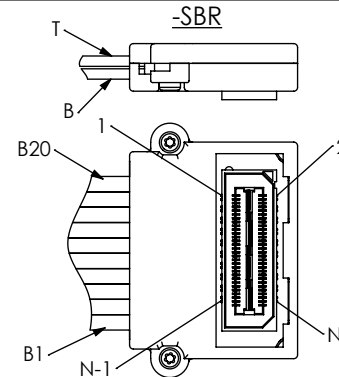

WIRING OPTION	FIRST END PIN #	SECOND END PIN #
**-1	1	1
**-2	1	2
**-3	1	N-1
**-4	1	N
-5	1	1
-6	1	2
-7	1	N-1
-8	1	N

** : AVAILABLE TO EXISTING CUSTOMERS ONLY

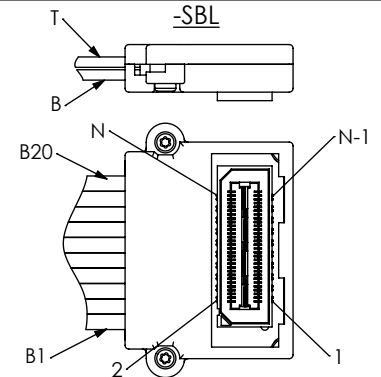

WIRING OPTION	FIRST END PIN #	SECOND END PIN #
**-1	1	1
**-2	1	2
**-3	1	N-1
**-4	1	N
-5	1	1
-6	1	2
-7	1	N-1
-8	1	N

** : AVAILABLE TO EXISTING CUSTOMERS ONLY

PROPRIETARY NOTE
 THIS DOCUMENT CONTAINS CONFIDENTIAL AND PROPRIETARY INFORMATION AND ALL DESIGN, MANUFACTURING, REPRODUCTION, USE, PATENT RIGHTS AND SALES RIGHTS ARE EXPRESSLY RESERVED BY SAMTEC, INC. THIS DOCUMENT SHALL NOT BE DISCLOSED, IN WHOLE OR PART, TO ANY UNAUTHORIZED PERSON OR ENTITY NOR REPRODUCED, TRANSFERRED OR INCORPORATED IN ANY OTHER PROJECT IN ANY MANNER WITHOUT THE EXPRESS WRITTEN CONSENT OF SAMTEC, INC.

DO NOT SCALE DRAWING

SHEET SCALE: 1:25:1



520 PARK EAST BLVD. NEW ALBANY, IN 47150
 PHONE: 812-944-6733 FAX: 812-948-5047
 e-Mail: info@SAMTEC.com code: 55322

DESCRIPTION:
 0.5mm HIGH-SPEED TWIN-AX CABLE ASSEMBLY

DWG. NO.
 HQDP-XXX-XX.XX-XXX-XXX-X-X

BY: BRATCHER 11/18/03 SHEET 3 OF 8

REVISION S

FIRST END - EDGE MOUNT (SEE TABLE 9, SHEET 7)
COVERS BROKEN OUT FOR CLARITY OF WIRE TERMINATION

SECOND END - EDGE MOUNT (SEE TABLE 9, SHEET 7)
COVERS BROKEN OUT FOR CLARITY OF WIRE TERMINATION

-TEU

WIRING OPTION	FIRST END PIN #	SECOND END PIN #	WIRE #
**1	1	1	B20
**2	1	2	B20
**3	1	N-1	B20
**4	1	N	B20
-5	1	1	B20
-6	1	2	B20
-7	1	N-1	B20
-8	1	N	B20

** AVAILABLE TO EXISTING CUSTOMERS ONLY

-TED

WIRING OPTION	FIRST END PIN #	SECOND END PIN #	WIRE #
**1	1	1	T1
**2	1	2	T1
**3	1	N-1	T1
**4	1	N	T1
-5	1	1	T1
-6	1	2	T1
-7	1	N-1	T1
-8	1	N	T1

** AVAILABLE TO EXISTING CUSTOMERS ONLY

-TEU

WIRING OPTION	FIRST END PIN #	SECOND END PIN #
**1	1	1
**2	1	2
**3	1	N-1
**4	1	N
-5	1	1
-6	1	2
-7	1	N-1
-8	1	N

** AVAILABLE TO EXISTING CUSTOMERS ONLY

-TED

WIRING OPTION	FIRST END PIN #	SECOND END PIN #
**1	1	1
**2	1	2
**3	1	N-1
**4	1	N
-5	1	1
-6	1	2
-7	1	N-1
-8	1	N

** AVAILABLE TO EXISTING CUSTOMERS ONLY

-SEU

WIRING OPTION	FIRST END PIN #	SECOND END PIN #	WIRE #
**1	1	1	B1
**2	1	2	B1
**3	1	N-1	B1
**4	1	N	B1
-5	1	1	B1
-6	1	2	B1
-7	1	N-1	B1
-8	1	N	B1

** AVAILABLE TO EXISTING CUSTOMERS ONLY

-SED

WIRING OPTION	FIRST END PIN #	SECOND END PIN #	WIRE #
**1	1	1	T20
**2	1	2	T20
**3	1	N-1	T20
**4	1	N	T20
-5	1	1	T20
-6	1	2	T20
-7	1	N-1	T20
-8	1	N	T20

** AVAILABLE TO EXISTING CUSTOMERS ONLY

-SEU

WIRING OPTION	FIRST END PIN #	SECOND END PIN #
**1	1	1
**2	1	2
**3	1	N-1
**4	1	N
-5	1	1
-6	1	2
-7	1	N-1
-8	1	N

** AVAILABLE TO EXISTING CUSTOMERS ONLY

-SED

WIRING OPTION	FIRST END PIN #	SECOND END PIN #
**1	1	1
**2	1	2
**3	1	N-1
**4	1	N
-5	1	1
-6	1	2
-7	1	N-1
-8	1	N

** AVAILABLE TO EXISTING CUSTOMERS ONLY

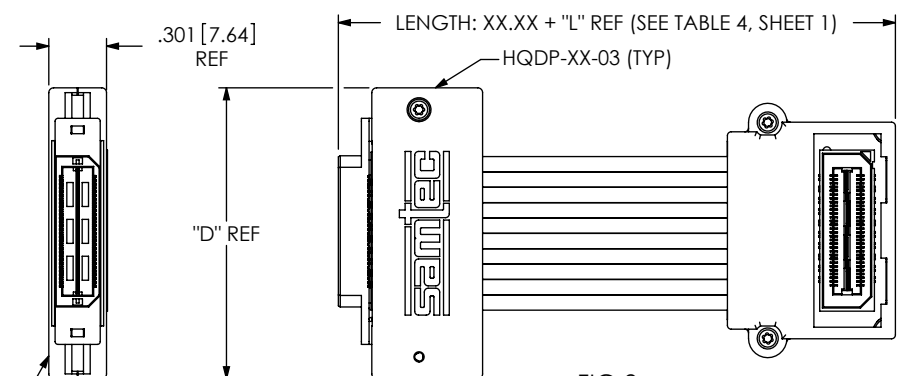

FIG 2
EDGE MOUNT (NO CAPTIVE PANEL SCREWS)
(HQDP-020-XX.XX-TEU-STR-X SHOWN)
(SAME AS FIG 1, UNLESS OTHERWISE STATED)

TABLE 5

No. OF POSITIONS	"D"	HQDP-XX-03	SUB-HQDP-X-XXX-XX-XX
-020	1.515[38.48]	HQDP-01-03	SUB-HQDP-X-030-03-XX
-040	2.303[58.50]	HQDP-02-03	SUB-HQDP-X-060-03-XX
-060	3.090[78.48]	HQDP-03-03	SUB-HQDP-X-090-03-XX
-080	3.878[98.50]	HQDP-04-03	SUB-HQDP-X-120-03-XX

PROPRIETARY NOTE
THIS DOCUMENT CONTAINS CONFIDENTIAL AND PROPRIETARY INFORMATION AND ALL DESIGN, MANUFACTURING, REPRODUCTION, USE, PATENT RIGHTS AND SALES RIGHTS ARE EXPRESSLY RESERVED BY SAMTEC, INC. THIS DOCUMENT SHALL NOT BE DISCLOSED, IN WHOLE OR PART, TO ANY UNAUTHORIZED PERSON OR ENTITY NOR REPRODUCED, TRANSFERRED OR INCORPORATED IN ANY OTHER PROJECT IN ANY MANNER WITHOUT THE EXPRESS WRITTEN CONSENT OF SAMTEC, INC.



520 PARK EAST BLVD, NEW ALBANY, IN 47150
PHONE: 812-944-6733 FAX: 812-948-5047
e-Mail: info@SAMTEC.com code: 55322

DO NOT SCALE DRAWING
SHEET SCALE: 1:1

DESCRIPTION:
0.5mm HIGH-SPEED TWIN-AX CABLE ASSEMBLY

DWG. NO.
HQDP-XXX-XX.XX-XXX-XXX-X-X

BY: BRATCHER 11/18/03 SHEET 4 OF 8

FIG 3
EDGE MOUNT (WITH CAPTIVE PANEL SCREWS)
(HQDP-020-XX.XX-SEU-XXX-5-F SHOWN)
(SAME AS FIG 2, UNLESS OTHERWISE STATED)

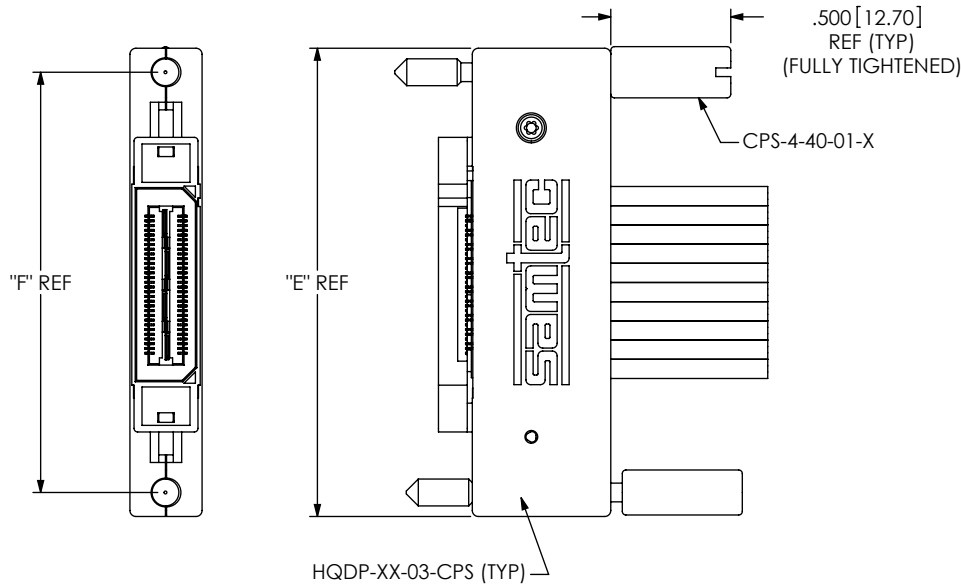

TABLE 6

No. OF POSITIONS	"E"	"F"	HQDP-XX-03-CPS
-020	1.951[49.56]	1.751[44.48]	HQDP-01-03-CPS
-040	2.739[69.57]	2.539[64.49]	HQDP-02-03-CPS
-060	3.526[89.56]	3.326[84.48]	HQDP-03-03-CPS
-080	4.314[109.58]	4.114[104.50]	HQDP-04-03-CPS

FIG 4
DOUBLE VERTICAL (WITH SCREW DOWN OPTION)
(HQDP-020-XX.XX-TTR-XXX-5-F SHOWN)
(SAME AS FIG 1, UNLESS OTHERWISE STATED)

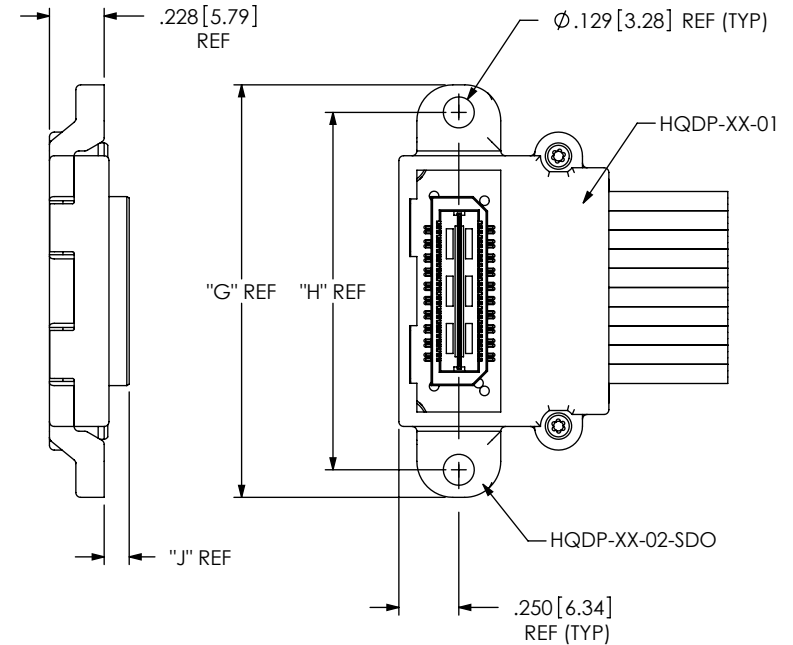

TABLE 7

No. OF POSITIONS	"G"	"H"	HQDP-XX-02-SDO
-020	1.719[43.68]	1.489[37.82]	HQDP-01-02-SDO
-040	2.644[67.16]	2.414[61.32]	HQDP-02-02-SDO
-060	3.569[90.65]	3.339[84.81]	HQDP-03-02-SDO
-080	4.494[114.15]	4.264[108.31]	HQDP-04-02-SDO

TABLE 8

END	"J"
-TXX	.104[2.65]
-SXX	.068[1.73]

FIG 5
(HQDP-020-XX.XX-TEU-STR-N SHOWN)
(SAME AS FIG 1, UNLESS OTHERWISE STATED)

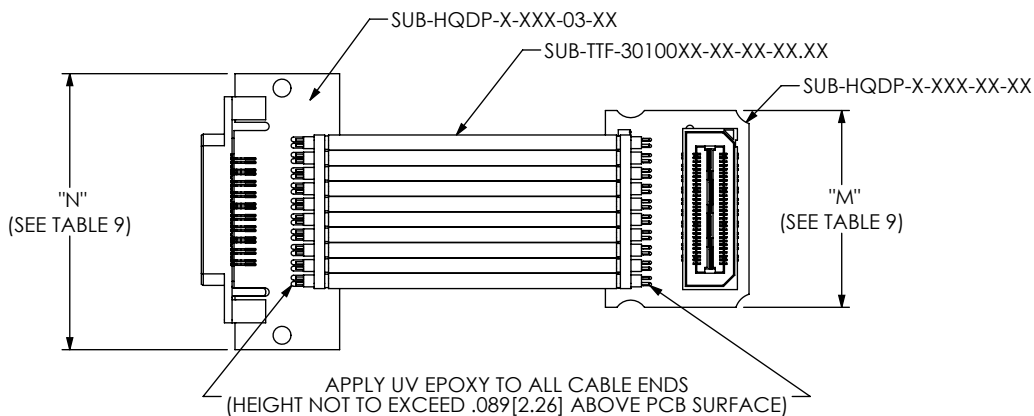

TABLE 9

No. OF POSITIONS	"M"	"N"
-020	1.025[26.04]	1.438[36.53]
-040	1.950[49.53]	2.225[56.52]
-060	2.875[73.03]	3.013[76.53]
-080	3.800[96.52]	3.800[96.52]

PROPRIETARY NOTE
THIS DOCUMENT CONTAINS CONFIDENTIAL AND PROPRIETARY INFORMATION AND ALL DESIGN, MANUFACTURING, REPRODUCTION, USE, PATENT RIGHTS AND SALES RIGHTS ARE EXPRESSLY RESERVED BY SAMTEC, INC. THIS DOCUMENT SHALL NOT BE DISCLOSED, IN WHOLE OR PART, TO ANY UNAUTHORIZED PERSON OR ENTITY NOR REPRODUCED, TRANSFERRED OR INCORPORATED IN ANY OTHER PROJECT IN ANY MANNER WITHOUT THE EXPRESS WRITTEN CONSENT OF SAMTEC, INC.

DO NOT SCALE DRAWING
SHEET SCALE: 1:25:1



520 PARK EAST BLVD, NEW ALBANY, IN 47150
PHONE: 812-944-6733 FAX: 812-948-5047
e-Mail: info@SAMTEC.com code: 55322

DESCRIPTION:
0.5mm HIGH-SPEED TWIN-AX CABLE ASSEMBLY

DWG. NO.
HQDP-XXX-XX.XX-XXX-XXX-X-X

BY: BRATCHER 11/18/03 SHEET 5 OF 8

FIG 6
(HQDP-020-XX.X-STL-TTR-5-D SHOWN)
(SAME AS FIG 1, UNLESS OTHERWISE STATED)

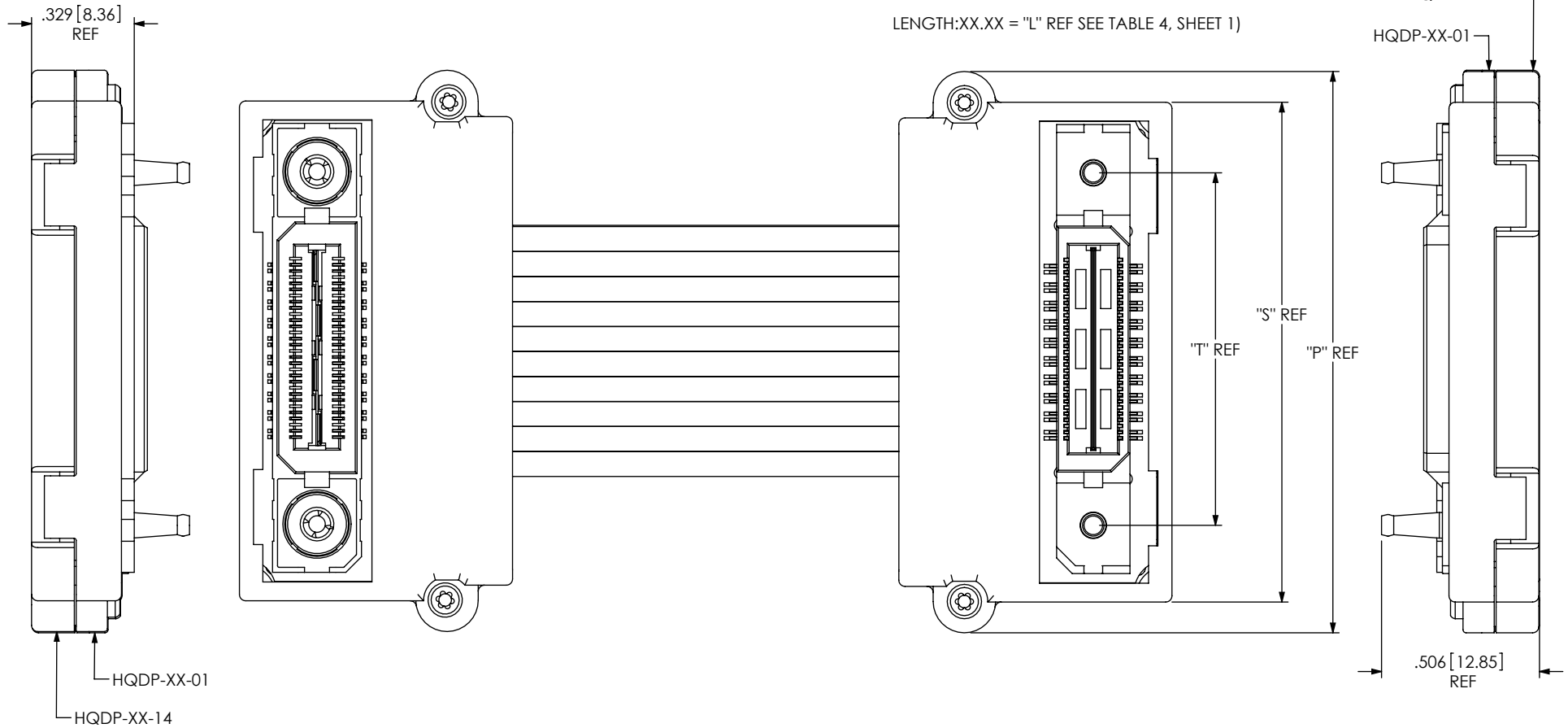

TABLE 11

No. OF POSITIONS	"P"		"S"		"T"		HQDP-XX-01	HQDP-XX-14	SUB-HQDP-X-XXX-XX-XX-RT1
-020	1.797	[45.64]	1.600	[40.64]	1.129	[28.68]	HQDP-05-01	HQDP-01-14	SUB-HQDP-X-020-XX-XX-RT1
-040	2.585	[65.66]	2.388	[60.66]	1.916	[48.67]	HQDP-06-01	HQDP-02-14	SUB-HQDP-X-040-XX-XX-RT1
-060	3.372	[85.65]	3.175	[80.65]	2.704	[68.68]	HQDP-07-01	HQDP-03-14	SUB-HQDP-X-060-XX-XX-RT1

PROPRIETARY NOTE
THIS DOCUMENT CONTAINS CONFIDENTIAL AND PROPRIETARY INFORMATION AND ALL DESIGN, MANUFACTURING, REPRODUCTION, USE, PATENT RIGHTS AND SALES RIGHTS ARE EXPRESSLY RESERVED BY SAMTEC, INC. THIS DOCUMENT SHALL NOT BE DISCLOSED, IN WHOLE OR PART, TO ANY UNAUTHORIZED PERSON OR ENTITY NOR REPRODUCED, TRANSFERRED OR INCORPORATED IN ANY OTHER PROJECT IN ANY MANNER WITHOUT THE EXPRESS WRITTEN CONSENT OF SAMTEC, INC.

DO NOT SCALE DRAWING

SHEET SCALE: 1:1



520 PARK EAST BLVD, NEW ALBANY, IN 47150
PHONE: 812-944-6733 FAX: 812-948-5047
e-Mail: info@SAMTEC.com code: 55322

DESCRIPTION:
0.5mm HIGH-SPEED TWIN-AX CABLE ASSEMBLY

DWG. NO.
HQDP-XXX-XX.XX-XXX-XXX-X-X

BY: BRATCHER 11/18/03 SHEET 6 OF 8

TABLE 9

FIRST END OPTION	FIRST END SUB-HQDP-X-XXX-XX-01	WIRING OPTION	FIRST END PIN #	SECOND END PIN #	WIRE #	SECOND END OPTION (SUB-HQDP-X-XXX-XX-XX)											
						-TTR	-TTL	-TBR	-TBL	-STR	-STL	-SBR	-SBL	-TEU	-TED	-SEU	-SED
-TTR	-T-XXX-01-01	**-1	1	1	B20	-T-XXX-02-02	N/A	N/A	-T-XXX-01-02	N/A	-S-XXX-01-01	-S-XXX-02-01	N/A	N/A	-T-XXX-03-02	-S-XXX-03-01	N/A
		**-2	1	2	B20	-T-XXX-02-01	N/A	N/A	-T-XXX-01-01	N/A	-S-XXX-01-02	-S-XXX-02-02	N/A	N/A	-T-XXX-03-01	-S-XXX-03-02	N/A
		**-3	1	N-1	B20	N/A	-T-XXX-01-01	-T-XXX-02-01	N/A	-S-XXX-02-02	N/A	N/A	-S-XXX-01-02	-T-XXX-03-01	N/A	N/A	-S-XXX-03-02
		**-4	1	N	B20	N/A	-T-XXX-01-02	-T-XXX-02-02	N/A	-S-XXX-02-01	N/A	N/A	-S-XXX-01-01	-T-XXX-03-02	N/A	N/A	-S-XXX-03-01
		-5	1	1	B20	-T-XXX-02-02	N/A	N/A	-T-XXX-01-02	N/A	-S-XXX-01-01	-S-XXX-02-01	N/A	N/A	-T-XXX-03-02	-S-XXX-03-01	N/A
		-6	1	2	B20	-T-XXX-02-01	N/A	N/A	-T-XXX-01-01	N/A	-S-XXX-01-02	-S-XXX-02-02	N/A	N/A	-T-XXX-03-01	-S-XXX-03-02	N/A
		-7	1	N-1	B20	N/A	-T-XXX-01-01	-T-XXX-02-01	N/A	-S-XXX-02-02	N/A	N/A	-S-XXX-01-02	-T-XXX-03-01	N/A	N/A	-S-XXX-03-02
		-8	1	N	B20	N/A	-T-XXX-01-02	-T-XXX-02-02	N/A	-S-XXX-02-01	N/A	N/A	-S-XXX-01-01	-T-XXX-03-02	N/A	N/A	-S-XXX-03-01
-TTL	-T-XXX-02-01	**-1	1	1	T1	N/A	-T-XXX-01-02	-T-XXX-02-02	N/A	-S-XXX-02-01	N/A	N/A	-S-XXX-01-01	-T-XXX-03-02	N/A	N/A	-S-XXX-03-01
		**-2	1	2	T1	N/A	-T-XXX-01-01	-T-XXX-02-01	N/A	-S-XXX-02-02	N/A	N/A	-S-XXX-01-02	-T-XXX-03-01	N/A	N/A	-S-XXX-03-02
		**-3	1	N-1	T1	-T-XXX-02-01	N/A	N/A	-T-XXX-01-01	N/A	-S-XXX-01-02	-S-XXX-02-02	N/A	N/A	-T-XXX-03-01	-S-XXX-03-02	N/A
		**-4	1	N	T1	-T-XXX-02-02	N/A	N/A	-T-XXX-01-02	N/A	-S-XXX-01-01	-S-XXX-02-01	N/A	N/A	-T-XXX-03-02	-S-XXX-03-01	N/A
		-5	1	1	T1	N/A	-T-XXX-01-02	-T-XXX-02-02	N/A	-S-XXX-02-01	N/A	N/A	-S-XXX-01-01	-T-XXX-03-02	N/A	N/A	-S-XXX-03-01
		-6	1	2	T1	N/A	-T-XXX-01-01	-T-XXX-02-01	N/A	-S-XXX-02-02	N/A	N/A	-S-XXX-01-02	-T-XXX-03-01	N/A	N/A	-S-XXX-03-02
		-7	1	N-1	T1	-T-XXX-02-01	N/A	N/A	-T-XXX-01-01	N/A	-S-XXX-01-02	-S-XXX-02-02	N/A	N/A	-T-XXX-03-01	-S-XXX-03-02	N/A
		-8	1	N	T1	-T-XXX-02-02	N/A	N/A	-T-XXX-01-02	N/A	-S-XXX-01-01	-S-XXX-02-01	N/A	N/A	-T-XXX-03-02	-S-XXX-03-01	N/A
-TBR	-T-XXX-01-01	**-1	1	1	T1	N/A	-T-XXX-01-02	-T-XXX-02-02	N/A	-S-XXX-02-01	N/A	N/A	-S-XXX-01-01	-T-XXX-03-02	N/A	N/A	-S-XXX-03-01
		**-2	1	2	T1	N/A	-T-XXX-01-01	-T-XXX-02-01	N/A	-S-XXX-02-02	N/A	N/A	-S-XXX-01-02	-T-XXX-03-01	N/A	N/A	-S-XXX-03-02
		**-3	1	N-1	T1	-T-XXX-02-01	N/A	N/A	-T-XXX-01-01	N/A	-S-XXX-01-02	-S-XXX-02-02	N/A	N/A	-T-XXX-03-01	-S-XXX-03-02	N/A
		**-4	1	N	T1	-T-XXX-02-02	N/A	N/A	-T-XXX-01-02	N/A	-S-XXX-01-01	-S-XXX-02-01	N/A	N/A	-T-XXX-03-02	-S-XXX-03-01	N/A
		-5	1	1	T1	N/A	-T-XXX-01-02	-T-XXX-02-02	N/A	-S-XXX-02-01	N/A	N/A	-S-XXX-01-01	-T-XXX-03-02	N/A	N/A	-S-XXX-03-01
		-6	1	2	T1	N/A	-T-XXX-01-01	-T-XXX-02-01	N/A	-S-XXX-02-02	N/A	N/A	-S-XXX-01-02	-T-XXX-03-01	N/A	N/A	-S-XXX-03-02
		-7	1	N-1	T1	-T-XXX-02-01	N/A	N/A	-T-XXX-01-01	N/A	-S-XXX-01-02	-S-XXX-02-02	N/A	N/A	-T-XXX-03-01	-S-XXX-03-02	N/A
		-8	1	N	T1	-T-XXX-02-02	N/A	N/A	-T-XXX-01-02	N/A	-S-XXX-01-01	-S-XXX-02-01	N/A	N/A	-T-XXX-03-02	-S-XXX-03-01	N/A
-TBL	-T-XXX-02-01	**-1	1	1	B20	-T-XXX-02-01	N/A	N/A	-T-XXX-01-02	N/A	-S-XXX-01-02	-S-XXX-02-01	N/A	N/A	-T-XXX-03-02	-S-XXX-03-01	N/A
		**-2	1	2	B20	-T-XXX-02-01	N/A	N/A	-T-XXX-01-01	N/A	-S-XXX-01-02	-S-XXX-02-02	N/A	N/A	-T-XXX-03-01	-S-XXX-03-02	N/A
		**-3	1	N-1	B20	N/A	-T-XXX-01-01	-T-XXX-02-01	N/A	-S-XXX-02-02	N/A	N/A	-S-XXX-01-02	-T-XXX-03-01	N/A	N/A	-S-XXX-03-02
		**-4	1	N	B20	N/A	-T-XXX-01-02	-T-XXX-02-02	N/A	-S-XXX-02-01	N/A	N/A	-S-XXX-01-01	-T-XXX-03-02	N/A	N/A	-S-XXX-03-01
		-5	1	1	B20	-T-XXX-02-02	N/A	N/A	-T-XXX-01-02	N/A	-S-XXX-01-01	-S-XXX-02-01	N/A	N/A	-T-XXX-03-02	-S-XXX-03-01	N/A
		-6	1	2	B20	-T-XXX-02-01	N/A	N/A	-T-XXX-01-01	N/A	-S-XXX-01-02	-S-XXX-02-02	N/A	N/A	-T-XXX-03-01	-S-XXX-03-02	N/A
		-7	1	N-1	B20	N/A	-T-XXX-01-01	-T-XXX-02-01	N/A	-S-XXX-02-02	N/A	N/A	-S-XXX-01-02	-T-XXX-03-01	N/A	N/A	-S-XXX-03-02
		-8	1	N	B20	N/A	-T-XXX-01-02	-T-XXX-02-02	N/A	-S-XXX-02-01	N/A	N/A	-S-XXX-01-01	-T-XXX-03-02	N/A	N/A	-S-XXX-03-01
-STR	-S-XXX-01-01	**-1	1	1	B1	N/A	-T-XXX-01-02	-T-XXX-02-02	N/A	-S-XXX-02-01	N/A	N/A	-S-XXX-01-01	-T-XXX-03-02	N/A	N/A	-S-XXX-03-01
		**-2	1	2	B1	N/A	-T-XXX-01-02	-T-XXX-02-02	N/A	-S-XXX-02-01	N/A	N/A	-S-XXX-01-01	-T-XXX-03-02	N/A	N/A	-S-XXX-03-01
		**-3	1	N-1	B1	-T-XXX-02-01	N/A	N/A	-T-XXX-01-02	N/A	-S-XXX-01-01	-S-XXX-02-01	N/A	N/A	-T-XXX-03-02	-S-XXX-03-01	N/A
		**-4	1	N	B1	-T-XXX-02-01	N/A	N/A	-T-XXX-01-01	N/A	-S-XXX-01-02	-S-XXX-02-02	N/A	N/A	-T-XXX-03-01	-S-XXX-03-02	N/A
		-5	1	1	B1	N/A	-T-XXX-01-01	-T-XXX-02-01	N/A	-S-XXX-02-02	N/A	N/A	-S-XXX-01-02	-T-XXX-03-01	N/A	N/A	-S-XXX-03-02
		-6	1	2	B1	N/A	-T-XXX-01-02	-T-XXX-02-02	N/A	-S-XXX-02-01	N/A	N/A	-S-XXX-01-01	-T-XXX-03-02	N/A	N/A	-S-XXX-03-01
		-7	1	N-1	B1	-T-XXX-02-02	N/A	N/A	-T-XXX-01-02	N/A	-S-XXX-01-01	-S-XXX-02-01	N/A	N/A	-T-XXX-03-02	-S-XXX-03-01	N/A
		-8	1	N	B1	-T-XXX-02-01	N/A	N/A	-T-XXX-01-01	N/A	-S-XXX-01-02	-S-XXX-02-02	N/A	N/A	-T-XXX-03-01	-S-XXX-03-02	N/A
-STL	-S-XXX-02-01	**-1	1	1	T20	-T-XXX-02-01	N/A	N/A	-T-XXX-01-01	N/A	-S-XXX-01-02	-S-XXX-02-02	N/A	N/A	-T-XXX-03-01	-S-XXX-03-02	N/A
		**-2	1	2	T20	-T-XXX-02-02	N/A	N/A	-T-XXX-01-02	N/A	-S-XXX-01-01	-S-XXX-02-01	N/A	N/A	-T-XXX-03-02	-S-XXX-03-01	N/A
		**-3	1	N-1	T20	N/A	-T-XXX-01-02	-T-XXX-02-02	N/A	-S-XXX-02-01	N/A	N/A	-S-XXX-01-01	-T-XXX-03-02	N/A	N/A	-S-XXX-03-01
		**-4	1	N	T20	N/A	-T-XXX-01-01	-T-XXX-02-01	N/A	-S-XXX-02-02	N/A	N/A	-S-XXX-01-02	-T-XXX-03-01	N/A	N/A	-S-XXX-03-02
		-5	1	1	T20	-T-XXX-02-01	N/A	N/A	-T-XXX-01-01	N/A	-S-XXX-01-02	-S-XXX-02-02	N/A	N/A	-T-XXX-03-01	-S-XXX-03-02	N/A
		-6	1	2	T20	-T-XXX-02-02	N/A	N/A	-T-XXX-01-02	N/A	-S-XXX-01-01	-S-XXX-02-01	N/A	N/A	-T-XXX-03-02	-S-XXX-03-01	N/A
		-7	1	N-1	T20	N/A	-T-XXX-01-02	-T-XXX-02-02	N/A	-S-XXX-02-01	N/A	N/A	-S-XXX-01-01	-T-XXX-03-02	N/A	N/A	-S-XXX-03-01
		-8	1	N	T20	N/A	-T-XXX-01-01	-T-XXX-02-01	N/A	-S-XXX-02-02	N/A	N/A	-S-XXX-01-02	-T-XXX-03-01	N/A	N/A	-S-XXX-03-02

** : AVAILABLE TO EXISTING CUSTOMERS ONLY

FOR RT1 OPTION SUB-ASSEMBLY ADD -RT1 TO THE END OF THE SUB-ASSEMBLY CALLOUT LISTED IN THE TABLE ABOVE.

PROPRIETARY NOTE
 THIS DOCUMENT CONTAINS CONFIDENTIAL AND PROPRIETARY INFORMATION AND ALL DESIGN, MANUFACTURING, REPRODUCTION, USE, PATENT RIGHTS AND SALES RIGHTS ARE EXPRESSLY RESERVED BY SAMTEC, INC. THIS DOCUMENT SHALL NOT BE DISCLOSED, IN WHOLE OR PART, TO ANY UNAUTHORIZED PERSON OR ENTITY NOR REPRODUCED, TRANSFERRED OR INCORPORATED IN ANY OTHER PROJECT IN ANY MANNER WITHOUT THE EXPRESS WRITTEN CONSENT OF SAMTEC, INC.



520 PARK EAST BLVD. NEW ALBANY, IN 47150
 PHONE: 812-944-6733 FAX: 812-948-5047
 e-Mail: info@SAMTEC.com code: 55322

DO NOT SCALE DRAWING

SHEET SCALE: 1.25:1

DESCRIPTION:
 0.5mm HIGH-SPEED TWIN-AX CABLE ASSEMBLY

DWG. NO.
 HQDP-XXX-XX.XX-XXX-XXX-X-X

BY: BRATCHER 11/18/03 SHEET 7 OF 8

		TABLE 9 (CONT)																			
FIRST END OPTION	FIRST END SUB-HQDP-X-XXX-XX-01	WIRING OPTION	FIRST END PIN #	SECOND END PIN #	WIRE #	SECOND END OPTION (SUB-HQDP-X-XXX-XX-XX)												-TEU	-TED	-SEU	-SED
						-TTR	-TTL	-TBR	-TBL	-STR	-STL	-SBR	-SBL	-TXX-01-01	-TXX-01-02	-TXX-02-01	-TXX-02-02				
-SBR	-S-XXX-01-01	**-1	1	1	T20	-T-XXX-02-01	N/A	N/A	-T-XXX-01-01	N/A	-S-XXX-01-02	-S-XXX-02-02	N/A	N/A	-T-XXX-03-01	-S-XXX-03-02	N/A	N/A			
		**-2	1	2	T20	-T-XXX-02-02	N/A	N/A	-T-XXX-01-02	N/A	-S-XXX-01-01	-S-XXX-02-01	N/A	N/A	-T-XXX-03-02	-S-XXX-03-01	N/A	N/A			
		**-3	1	N-1	T20	N/A	-T-XXX-01-02	-T-XXX-02-02	N/A	-S-XXX-02-01	N/A	N/A	-S-XXX-01-01	-T-XXX-03-02	N/A	N/A	-S-XXX-03-01	-S-XXX-03-01			
		**-4	1	N	T20	N/A	-T-XXX-01-01	-T-XXX-02-01	N/A	-S-XXX-02-02	N/A	N/A	-S-XXX-01-02	-T-XXX-03-01	N/A	N/A	-S-XXX-03-02	N/A			
		-5	1	1	T20	-T-XXX-02-01	N/A	N/A	-T-XXX-01-01	N/A	-S-XXX-01-02	-S-XXX-02-02	N/A	N/A	-T-XXX-03-01	-S-XXX-03-02	N/A	N/A			
		-6	1	2	T20	-T-XXX-02-02	N/A	N/A	-T-XXX-01-02	N/A	-S-XXX-01-01	-S-XXX-02-01	N/A	N/A	-T-XXX-03-02	-S-XXX-03-01	N/A	N/A			
		-7	1	N-1	T20	N/A	-T-XXX-01-02	-T-XXX-02-02	N/A	-S-XXX-02-01	N/A	N/A	-S-XXX-01-01	-T-XXX-03-02	N/A	N/A	-S-XXX-03-01	-S-XXX-03-01			
		-8	1	N	T20	N/A	-T-XXX-01-01	-T-XXX-02-01	N/A	-S-XXX-02-02	N/A	N/A	-S-XXX-01-02	-T-XXX-03-01	N/A	N/A	-S-XXX-03-02	N/A			
-SBL	-S-XXX-02-01	**-1	1	1	B1	N/A	-T-XXX-01-01	-T-XXX-02-01	N/A	-S-XXX-02-02	N/A	N/A	-S-XXX-01-02	-T-XXX-03-01	N/A	N/A	-S-XXX-03-02	N/A			
		**-2	1	2	B1	N/A	-T-XXX-01-02	-T-XXX-02-02	N/A	-S-XXX-02-01	N/A	N/A	-S-XXX-01-01	-T-XXX-03-02	N/A	N/A	-S-XXX-03-01	-S-XXX-03-01			
		**-3	1	N-1	B1	-T-XXX-02-02	N/A	N/A	-T-XXX-01-02	N/A	-S-XXX-01-01	-S-XXX-02-01	N/A	N/A	-T-XXX-03-02	-S-XXX-03-01	N/A	N/A			
		**-4	1	N	B1	-T-XXX-02-01	N/A	N/A	-T-XXX-01-01	N/A	-S-XXX-01-02	-S-XXX-02-02	N/A	N/A	-T-XXX-03-01	-S-XXX-03-02	N/A	N/A			
		-5	1	1	B1	N/A	-T-XXX-01-01	-T-XXX-02-01	N/A	-S-XXX-02-02	N/A	N/A	-S-XXX-01-02	-T-XXX-03-01	N/A	N/A	-S-XXX-03-02	N/A			
		-6	1	2	B1	N/A	-T-XXX-01-02	-T-XXX-02-02	N/A	-S-XXX-02-01	N/A	N/A	-S-XXX-01-01	-T-XXX-03-02	N/A	N/A	-S-XXX-03-01	-S-XXX-03-01			
		-7	1	N-1	B1	-T-XXX-02-02	N/A	N/A	-T-XXX-01-02	N/A	-S-XXX-01-01	-S-XXX-02-01	N/A	N/A	-T-XXX-03-02	-S-XXX-03-01	N/A	N/A			
		-8	1	N	B1	-T-XXX-02-01	N/A	N/A	-T-XXX-01-01	N/A	-S-XXX-01-02	-S-XXX-02-02	N/A	N/A	-T-XXX-03-01	-S-XXX-03-02	N/A	N/A			
-TEU	-T-XXX-03-01	**-1	1	1	B20	-T-XXX-02-02	N/A	N/A	-T-XXX-01-02	N/A	-S-XXX-01-01	-S-XXX-02-01	N/A	N/A	-T-XXX-03-02	-S-XXX-03-01	N/A	N/A			
		**-2	1	2	B20	-T-XXX-02-01	N/A	N/A	-T-XXX-01-01	N/A	-S-XXX-01-02	-S-XXX-02-02	N/A	N/A	-T-XXX-03-01	-S-XXX-03-02	N/A	N/A			
		**-3	1	N-1	B20	N/A	-T-XXX-01-01	-T-XXX-02-01	N/A	-S-XXX-02-02	N/A	N/A	-S-XXX-01-02	-T-XXX-03-01	N/A	N/A	-S-XXX-03-02	-S-XXX-03-01			
		**-4	1	N	B20	N/A	-T-XXX-01-02	-T-XXX-02-02	N/A	-S-XXX-02-01	N/A	N/A	-S-XXX-01-01	-T-XXX-03-02	N/A	N/A	-S-XXX-03-01	-S-XXX-03-01			
		-5	1	1	B20	-T-XXX-02-02	N/A	N/A	-T-XXX-01-02	N/A	-S-XXX-01-01	-S-XXX-02-01	N/A	N/A	-T-XXX-03-02	-S-XXX-03-01	N/A	N/A			
		-6	1	2	B20	-T-XXX-02-01	N/A	N/A	-T-XXX-01-01	N/A	-S-XXX-01-02	-S-XXX-02-02	N/A	N/A	-T-XXX-03-01	-S-XXX-03-02	N/A	N/A			
		-7	1	N-1	B20	N/A	-T-XXX-01-01	-T-XXX-02-01	N/A	-S-XXX-02-02	N/A	N/A	-S-XXX-01-02	-T-XXX-03-01	N/A	N/A	-S-XXX-03-02	-S-XXX-03-01			
		-8	1	N	B20	N/A	-T-XXX-01-02	-T-XXX-02-02	N/A	-S-XXX-02-01	N/A	N/A	-S-XXX-01-01	-T-XXX-03-02	N/A	N/A	-S-XXX-03-01	-S-XXX-03-01			
-TED	-T-XXX-03-01	**-1	1	1	T1	N/A	-T-XXX-01-02	-T-XXX-02-02	N/A	-S-XXX-02-01	N/A	N/A	-S-XXX-01-01	-T-XXX-03-02	N/A	N/A	-S-XXX-03-01	-S-XXX-03-01			
		**-2	1	2	T1	N/A	-T-XXX-01-01	-T-XXX-02-01	N/A	-S-XXX-02-02	N/A	N/A	-S-XXX-01-02	-T-XXX-03-01	N/A	N/A	-S-XXX-03-02	-S-XXX-03-02			
		**-3	1	N-1	T1	-T-XXX-02-01	N/A	N/A	-T-XXX-01-01	N/A	-S-XXX-01-02	-S-XXX-02-02	N/A	N/A	-T-XXX-03-02	-S-XXX-03-01	N/A	N/A			
		**-4	1	N	T1	-T-XXX-02-02	N/A	N/A	-T-XXX-01-02	N/A	-S-XXX-01-01	-S-XXX-02-01	N/A	N/A	-T-XXX-03-02	-S-XXX-03-01	N/A	N/A			
		-5	1	1	T1	N/A	-T-XXX-01-02	-T-XXX-02-02	N/A	-S-XXX-02-01	N/A	N/A	-S-XXX-01-01	-T-XXX-03-02	N/A	N/A	-S-XXX-03-01	-S-XXX-03-01			
		-6	1	2	T1	N/A	-T-XXX-01-01	-T-XXX-02-01	N/A	-S-XXX-02-02	N/A	N/A	-S-XXX-01-02	-T-XXX-03-01	N/A	N/A	-S-XXX-03-02	-S-XXX-03-02			
		-7	1	N-1	T1	-T-XXX-02-01	N/A	N/A	-T-XXX-01-01	N/A	-S-XXX-01-02	-S-XXX-02-02	N/A	N/A	-T-XXX-03-01	-S-XXX-03-02	N/A	N/A			
		-8	1	N	T1	-T-XXX-02-02	N/A	N/A	-T-XXX-01-02	N/A	-S-XXX-01-01	-S-XXX-02-01	N/A	N/A	-T-XXX-03-02	-S-XXX-03-01	N/A	N/A			
-SEU	-S-XXX-03-01	**-1	1	1	B1	N/A	-T-XXX-01-01	-T-XXX-02-01	N/A	-S-XXX-02-02	N/A	N/A	-S-XXX-01-02	-T-XXX-03-01	N/A	N/A	-S-XXX-03-02	-S-XXX-03-02			
		**-2	1	2	B1	N/A	-T-XXX-01-02	-T-XXX-02-02	N/A	-S-XXX-02-01	N/A	N/A	-S-XXX-01-01	-T-XXX-03-02	N/A	N/A	-S-XXX-03-01	-S-XXX-03-01			
		**-3	1	N-1	B1	-T-XXX-02-02	N/A	N/A	-T-XXX-01-02	N/A	-S-XXX-01-01	-S-XXX-02-01	N/A	N/A	-T-XXX-03-02	-S-XXX-03-01	N/A	N/A			
		**-4	1	N	B1	-T-XXX-02-01	N/A	N/A	-T-XXX-01-01	N/A	-S-XXX-01-02	-S-XXX-02-02	N/A	N/A	-T-XXX-03-01	-S-XXX-03-02	N/A	N/A			
		-5	1	1	B1	N/A	-T-XXX-01-01	-T-XXX-02-01	N/A	-S-XXX-02-02	N/A	N/A	-S-XXX-01-02	-T-XXX-03-01	N/A	N/A	-S-XXX-03-02	-S-XXX-03-02			
		-6	1	2	B1	N/A	-T-XXX-01-02	-T-XXX-02-02	N/A	-S-XXX-02-01	N/A	N/A	-S-XXX-01-01	-T-XXX-03-02	N/A	N/A	-S-XXX-03-01	-S-XXX-03-01			
		-7	1	N-1	B1	-T-XXX-02-02	N/A	N/A	-T-XXX-01-02	N/A	-S-XXX-01-01	-S-XXX-02-01	N/A	N/A	-T-XXX-03-02	-S-XXX-03-01	N/A	N/A			
		-8	1	N	B1	-T-XXX-02-01	N/A	N/A	-T-XXX-01-01	N/A	-S-XXX-01-02	-S-XXX-02-02	N/A	N/A	-T-XXX-03-01	-S-XXX-03-02	N/A	N/A			
-SED	-S-XXX-03-01	**-1	1	1	T20	-T-XXX-02-01	N/A	N/A	-T-XXX-01-01	N/A	-S-XXX-01-02	-S-XXX-02-02	N/A	N/A	-T-XXX-03-01	-S-XXX-03-02	N/A	N/A			
		**-2	1	2	T20	-T-XXX-02-02	N/A	N/A	-T-XXX-01-02	N/A	-S-XXX-01-01	-S-XXX-02-01	N/A	N/A	-T-XXX-03-02	-S-XXX-03-01	N/A	N/A			
		**-3	1	N-1	T20	N/A	-T-XXX-01-02	-T-XXX-02-02	N/A	-S-XXX-02-01	N/A	N/A	-S-XXX-01-01	-T-XXX-03-02	N/A	N/A	-S-XXX-03-01	-S-XXX-03-01			
		**-4	1	N	T20	N/A	-T-XXX-01-01	-T-XXX-02-01	N/A	-S-XXX-02-02	N/A	N/A	-S-XXX-01-02	-T-XXX-03-01	N/A	N/A	-S-XXX-03-02	-S-XXX-03-02			
		-5	1	1	T20	-T-XXX-02-01	N/A	N/A	-T-XXX-01-01	N/A	-S-XXX-01-02	-S-XXX-02-02	N/A	N/A	-T-XXX-03-01	-S-XXX-03-02	N/A	N/A			
		-6	1	2	T20	-T-XXX-02-02	N/A	N/A	-T-XXX-01-02	N/A	-S-XXX-01-01	-S-XXX-02-01	N/A	N/A	-T-XXX-03-02	-S-XXX-03-01	N/A	N/A			
		-7	1	N-1	T20	N/A	-T-XXX-01-02	-T-XXX-02-02	N/A	-S-XXX-02-01	N/A	N/A	-S-XXX-01-01	-T-XXX-03-02	N/A	N/A	-S-XXX-03-01	-S-XXX-03-01			
		-8	1	N	T20	N/A	-T-XXX-01-01	-T-XXX-02-01	N/A	-S-XXX-02-02	N/A	N/A	-S-XXX-01-02	-T-XXX-03-01	N/A	N/A	-S-XXX-03-02	-S-XXX-03-02			

** : AVAILABLE TO EXISTING CUSTOMERS ONLY

FOR RT1 OPTION SUB-ASSEMBLY ADD -RT1 TO THE END OF THE SUB-ASSEMBLY CALLOUT LISTED IN THE TABLE ABOVE.

PROPRIETARY NOTE
 THIS DOCUMENT CONTAINS CONFIDENTIAL AND PROPRIETARY INFORMATION AND ALL DESIGN, MANUFACTURING, REPRODUCTION, USE, PATENT RIGHTS AND SALES RIGHTS ARE EXPRESSLY RESERVED BY SAMTEC, INC. THIS DOCUMENT SHALL NOT BE DISCLOSED, IN WHOLE OR PART, TO ANY UNAUTHORIZED PERSON OR ENTITY NOR REPRODUCED, TRANSFERRED OR INCORPORATED IN ANY OTHER PROJECT IN ANY MANNER WITHOUT THE EXPRESS WRITTEN CONSENT OF SAMTEC, INC.



520 PARK EAST BLVD, NEW ALBANY, IN 47150
 PHONE: 812-944-6733 FAX: 812-948-5047
 e-Mail: info@SAMTEC.com code: 55322

DO NOT SCALE DRAWING

SHEET SCALE: 1:25:1

DESCRIPTION:
 0.5mm HIGH-SPEED TWIN-AX CABLE ASSEMBLY

DWG. NO.
HQDP-XXX-XX.XX-XXX-XXX-X-X

BY: BRATCHER 11/18/03 SHEET 8 OF 8