

DESIGNED & DIMENSIONED  
IN MILLIMETERS [INCHES]

RF058-XXXXX-XXXXXX-XXXX

DO NOT  
SCALE FROM  
THIS PRINT

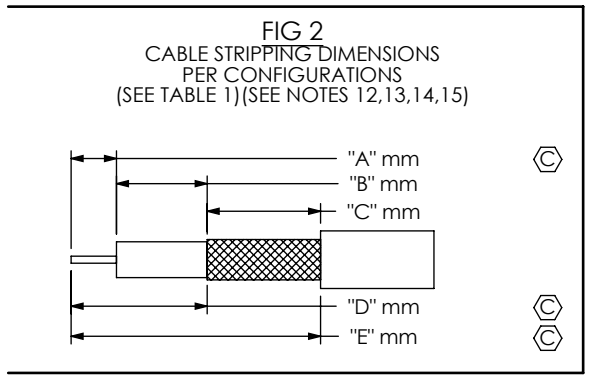

STYLE	CABLE CUT LENGTH		HI POT
	SUBTRACTOR	DCV	
-05SRX	9.2 [0.36]	1000	
-06SPX	15.3 [0.60]	1000	
-01BJX	8.7 [0.34]	1000	
-01SBX	8.7 [0.34]	1000	
-01SPX	5.2 [0.20]	1000	
-SING	0.0 [0.00]	1000	

LENGTH	TOLERANCE
0100-0200 [3.92-7.87]	+3.0 [.12]/-0.0 [0.00]
0200-0500 [7.87-19.69]	+5.0 [.20]/-0.0 [0.00]
0500-1100 [19.69-43.30]	+10.0 [.40]/-0.0 [0.00]
>1100 [43.30]	± 1%

CABLE CALLOUT  
058: CCA-058 (RG-58 COAXIAL CABLE)

END 1 CONNECTOR  
-05SR: TNC-P-C-XX-SR-C10 (SEE SHEET 2)  
-06SP: NTPE-P-C-XX-ST-C10 (SEE SHEET 2)  
-01BJ: SMA-J-C-XX-ST-B10 (SEE SHEET 2)  
-01SB: SMA-J-C-XX-ST-S10 (SEE SHEET 2)  
-01SP: SMA-P-C-XX-ST-C10 (SEE SHEET 2)

END 1 PLATING OPTION  
1: GOLD ALL COMPONENTS  
2: GOLD/NICKEL  
3: ALTERNATE GOLD / NICKEL  
7. ALTERNATE GOLD MEDIUM/ GOLD FLASH (SEE SHEET 2 FOR PLATING SPECIFICS)

OVERALL CABLE LENGTH  
MILLIMETERS OF CABLE  
0100 MIN. (SEE NOTE 8 & 9)

END 2 PLATING OPTION  
1: GOLD ALL COMPONENTS  
2: GOLD/NICKEL  
3: ALTERNATE GOLD / NICKEL  
7. ALTERNATE GOLD MEDIUM/ GOLD FLASH (SEE SHEET 2 FOR PLATING SPECIFICS) (LEAVE BLANK FOR -SING OR -XXXXXX END 2 PREPARATION)

END 2 CONNECTOR OR PREPARATION  
-05SR: TNC-P-C-XX-SR-C10 (SEE SHEET 2)  
-06SP: NTPE-P-C-XX-ST-C10 (SEE SHEET 2)  
-01BJ: SMA-J-C-XX-ST-B10 (SEE SHEET 2)  
-01SB: SMA-J-C-XX-ST-S10 (SEE SHEET 2)  
-01SP: SMA-P-C-XX-ST-C10 (SEE SHEET 2)  
-SING: SINGLE ENDED (ONE END ONLY, SEE NOTE 11)  
-XXXXXX: STRIPPED AND TINNED (THIS END ONLY- SEE NOTES 11-16 & SHEET 2, FIG. 3)

DO NOT LEAVE ANY SPACE BLANK,  
EACH MUST CONTAIN A  
NUMERIC CHARACTER 0 THRU 9.

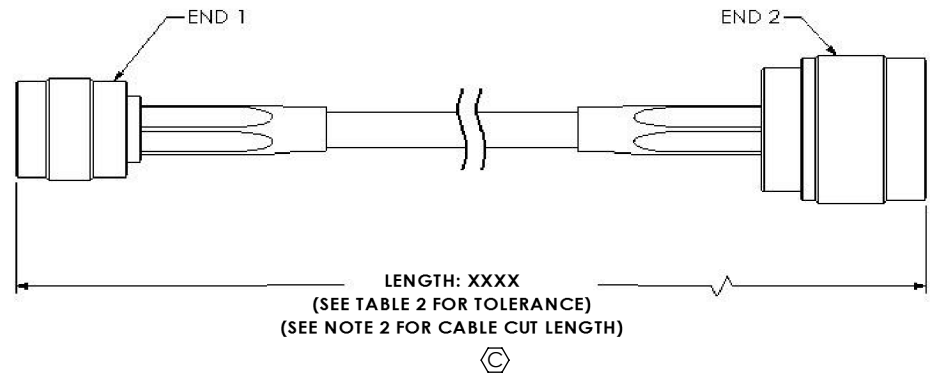

FIG 1  
RF058-05SRX-06SPX-XXXX SHOWN

- NOTES:
- ⊕ REPRESENTS A CRITICAL DIMENSION
  - CABLE CUT LENGTH:  
= (LENGTH: XXXX) - (SUBTRACTOR FOR END 1) - (SUBTRACTOR FOR END 2).  
(SEE TABLE 1 FOR SUBTRACTORS)
  - ⊕ ASSEMBLY TO BE 100% TESTED FOR OPENS & SHORTS
  - ⊕ ASSEMBLY TO BE 100% HI-POT TESTED PER TABLE 1 AND THE TEST VOLTAGE FOR THE ASSEMBLY SHOULD BE SET TO THE END OPTION WITH THE LOWEST TEST VOLTAGE RATING.
  - AFTER FINAL ELECTRICAL TESTS, LABEL EACH CABLE ASSEMBLY WITH 1 LABEL -ET
  - CRITICALS ON CONNECTOR PRINTS TO BE CHECKED IN PROCESS
  - FINISHED ASSEMBLIES TO BE PACKAGED PER PACKAGING STANDARD CO-HD-WI-3040-M. LOCK WASHERS AND NUTS TO BE SHIPPED UNASSEMBLED. GASKETS TO BE INSTALLED ON CABLE.
  - CABLE STOCKED IN INCHES, 1 INCH = 25.4 MILLIMETERS
  - CABLE LENGTHS LONGER THAN 1000 MILLIMETERS ARE NOT SUPPORTED BY S.I. TEST DATA
  - MINIMUM BEND RADIUS FOR RG058 = 48.3 [1.90]
  - FOR SING ENDED OR STRIPPED AND TINNED ASSEMBLIES: MAKE A DOUBLE ENDED ASSEMBLY AT TWICE THE CABLE LENGTH AND TEST BEFORE CUTTING ASSEMBLY IN HALF.
  - DIM "A", "B", AND "C" HAVE A MINIMUM VALUE OF 0.0mm & A MAXIMUM VALUE OF 9.9mm
  - PRODUCTION OF STRIP AND TIN FOR CENTER DIELECTIC USE: A
  - PRODUCTION OF STRIP AND TIN FOR SHIELD USE: D=A+B
  - PRODUCTION OF STRIP AND TIN FOR JACKET USE: E=A+B+C
  - FOR STRIPPED AND TINNED OPTION, ONLY THE CENTER CONDUCTOR IS TINNED
  - CONNECTOR TO BE ORIENTED ACCORDING TO CO-HD-WI-3048-M.

**THIS PRODUCT MANUFACTURED WITH LEAD-FREE PROCESSING**

F:\DWG\MISC\MKTG\RF058-XXXXX-XXXXXX-XXXX-MKT.SLDDRW		<p>520 PARK EAST BLVD, NEW ALBANY, IN 47150 PHONE: 812-944-6733 FAX: 812-948-5047 e-Mail info@SAMTEC.com code 55322</p>
UNLESS OTHERWISE SPECIFIED, DIMENSIONS ARE IN MILLIMETERS [INCHES]. TOLERANCES ARE: DECIMALS ANGLES .X: ±0.3 [0.1] 2° .XX: ±0.13 [0.05] .XXX: ±0.051 [0.020]	<p>PROPRIETARY NOTE</p> <p>THIS DOCUMENT CONTAINS INFORMATION CONFIDENTIAL AND PROPRIETARY TO SAMTEC, INC. AND SHALL NOT BE REPRODUCED OR TRANSFERRED TO OTHER DOCUMENTS OR DISCLOSED TO OTHERS OR USED FOR ANY PURPOSE OTHER THAN THAT WHICH IT WAS OBTAINED WITHOUT THE EXPRESSED WRITTEN CONSENT OF SAMTEC, INC.</p>	
<p>MATERIAL: DO NOT SCALE DRAWING SHEET SCALE: 2:1 SEE END 1 AND END 2 ASSEMBLY PRINTS</p>		<p>DESCRIPTION: RF058 CABLE ASSEMBLY</p> <p>DWG. NO. RF058-XXXXX-XXXXXX-XXXX</p> <p>BY: TIM P. 5/6/2005 SHEET 1 OF 2</p>

REVISION Q

**-05SR**  
(STRAIGHT PLUG)

(USE DRAWING No. TNC-P-C-XX-SR-C10 FOR ASSEMBLY INSTRUCTIONS)

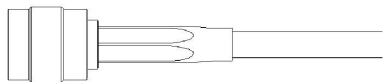

PLATING OPTION

- 3: 10μ" MIN. GOLD CENTER CONTACT
- 100μ" MIN. NICKEL OUTER CONTACT
- 100μ" MIN. NICKEL REMAINING METAL PARTS  
(END CONNECTOR P/N: TNC-P-C-GN-SR-C10)

NOTE: ALL CRITICAL DIMENSIONS ON TNC-P-C-XX-SR-C10 THAT APPLY MUST BE VERIFIED.

**-06SP**  
(STRAIGHT PLUG)

(USE DRAWING No. NTPE-P-C-XX-ST-C10 FOR ASSEMBLY INSTRUCTIONS)

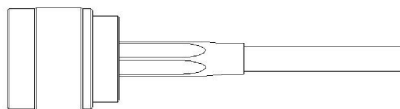

PLATING OPTIONS

- 2: 30μ" MIN. GOLD CENTER CONTACT
- 100μ" MIN. NICKEL OUTER CONTACT
- 100μ" MIN. NICKEL REMAINING METAL PARTS  
(END CONNECTOR P/N: NTPE-P-C-HN-ST-C10)

- 3: 10μ" MIN. GOLD CENTER CONTACT
- 100μ" MIN. NICKEL OUTER CONTACT
- 100μ" MIN. NICKEL REMAINING METAL PARTS  
(END CONNECTOR P/N: NTPE-P-C-GN-ST-C10)

NOTE: ALL CRITICAL DIMENSIONS ON NTPE-P-C-XX-ST-C10 THAT APPLY MUST BE VERIFIED.

**-01BJ**  
(STRAIGHT BULKHEAD JACK)

(USE DRAWING No. SMA-J-C-XX-ST-B10 FOR ASSEMBLY INSTRUCTIONS)

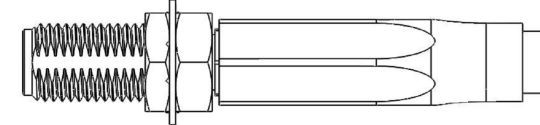

PLATING OPTIONS

- 1: 30μ" MIN. GOLD CENTER CONTACT
- 3μ" MIN. GOLD OUTER CONTACT
- 3μ" MIN. GOLD REMAINING METAL PARTS  
(END CONNECTOR P/N: SMA-J-C-H-ST-B10)

- 7: 10μ" MIN. GOLD CENTER CONTACT
- 3μ" MIN. GOLD OUTER CONTACT
- 3μ" MIN. GOLD REMAINING METAL PARTS  
(END CONNECTOR P/N: SMA-J-C-GF-ST-B10)

NOTE: ALL CRITICAL DIMENSIONS ON SMA-J-C-XX-ST-B10 THAT APPLY MUST BE VERIFIED.

**-01SB**

(SEALED STRAIGHT BULKHEAD JACK)

(USE DRAWING No. SMA-J-C-XX-ST-S10 FOR ASSEMBLY INSTRUCTIONS)

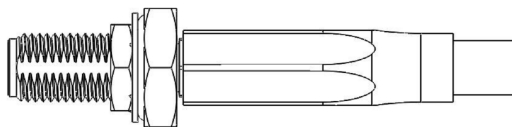

PLATING OPTIONS

- 1: 30μ" MIN. GOLD CENTER CONTACT
- 3μ" MIN. GOLD OUTER CONTACT
- 3μ" MIN. GOLD REMAINING METAL PARTS  
(END CONNECTOR P/N: SMA-J-C-H-ST-S10)

- 7: 10μ" MIN. GOLD CENTER CONTACT
- 3μ" MIN. GOLD OUTER CONTACT
- 3μ" MIN. GOLD REMAINING METAL PARTS  
(END CONNECTOR P/N: SMA-J-C-GF-ST-S10)

NOTE: ALL CRITICAL DIMENSIONS ON SMA-J-C-XX-ST-S10 THAT APPLY MUST BE VERIFIED.

**-01SP**

(STRAIGHT PLUG)

(USE DRAWING No. SMA-P-C-XX-ST-C10 FOR ASSEMBLY INSTRUCTIONS)

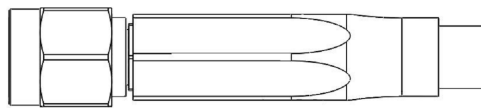

PLATING OPTIONS

- 1: 30μ" MIN. GOLD CENTER CONTACT
- 3μ" MIN. GOLD OUTER CONTACT
- 3μ" MIN. GOLD REMAINING METAL PARTS  
(END CONNECTOR P/N: SMA-P-C-H-ST-C10)

- 7: 10μ" MIN. GOLD CENTER CONTACT
- 3μ" MIN. GOLD OUTER CONTACT
- 3μ" MIN. GOLD REMAINING METAL PARTS  
(END CONNECTOR P/N: SMA-P-C-GF-ST-C10)

NOTE: ALL CRITICAL DIMENSIONS ON SMA-P-C-XX-ST-C10 THAT APPLY MUST BE VERIFIED.

FIG.3  
RF058-05SRX-102T48-XXXX SHOWN

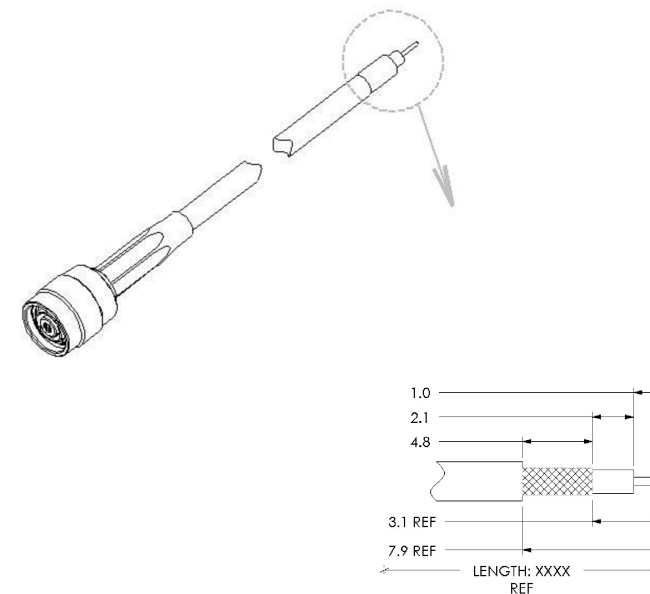

PROPRIETARY NOTE

THIS DOCUMENT CONTAINS INFORMATION CONFIDENTIAL AND PROPRIETARY TO SAMTEC, INC. AND SHALL NOT BE REPRODUCED OR TRANSFERRED TO OTHER DOCUMENTS OR DISCLOSED TO OTHERS OR USED FOR ANY PURPOSE OTHER THAN THAT WHICH IT WAS OBTAINED WITHOUT THE EXPRESSED WRITTEN CONSENT OF SAMTEC, INC.

DO NOT SCALE DRAWING

SHEET SCALE: 1:1



520 PARK EAST BLVD, NEW ALBANY, IN 47150  
PHONE: 812-944-6733 FAX: 812-948-5047  
e-Mail: info@SAMTEC.com code 55322

DESCRIPTION: RF058 CABLE ASSEMBLY

DWG. NO. RF058-XXXXX-XXXXXX-XXXX

BY: TIM P. 5/6/2005 SHEET 2 OF 2