

THIS PRODUCT MANUFACTURED WITH LEAD-FREE PROCESSING

DESIGNED & DIMENSIONED IN MILLIMETERS [INCHES]

DO NOT SCALE FROM THIS PRINT

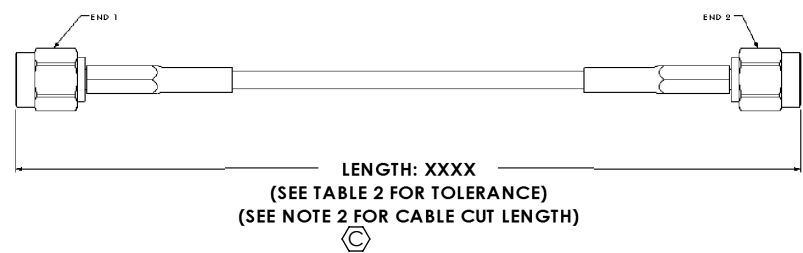
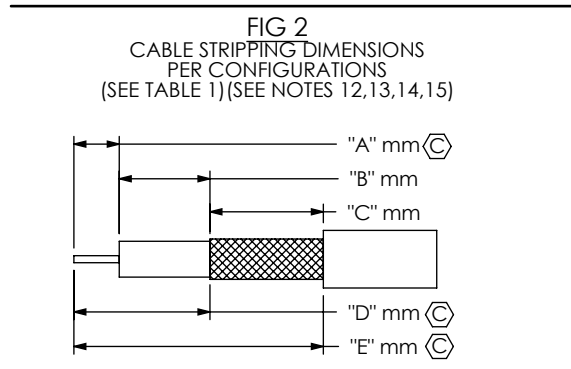

FIG 1
RS316-01SPX-0TSPX-XXXX SHOWN

RS316-XXXXX-XXXXXX-XXXX

CABLE CALL OUT
RS316: CCA-316-S (RG316 CABLE, DOUBLE SHIELD)

END 1 CONNECTOR
-0TSP: SMA-P-C-XX-ST-CA1S (SEE SHEET 2)
-01BJ: SMA-J-C-XX-ST-BH1S (SEE SHEET 3)
-02SP: MCX-P-C-XX-ST-CA1S (SEE SHEET 3)
-02SJ: MCX-J-C-XX-ST-CA1S (SEE SHEET 3)
-03SP: MMCX-P-C-XX-ST-CA1S (SEE SHEET 3)
-04BJ: BNC5-J-C-XX-ST-BH1S (SEE SHEET 3)
-05SP: TNC-P-C-XX-ST-CA1S (SEE SHEET 3)

END 1 PLATING OPTION
1: GOLD ALL COMPONENTS
2: GOLD / NICKEL COMBINATION
3: ALTERNATE GOLD / NICKEL
(SEE SHEET 2 FOR PLATING SPECIFICS)

OVERALL CABLE LENGTH
MILLIMETERS OF CABLE
0100 MIN. (SEE NOTE 8 & 9)

END 2 PLATING OPTION
1: GOLD ALL COMPONENTS
2: GOLD / NICKEL COMBINATION
3: ALTERNATE GOLD / NICKEL
(LEAVE BLANK FOR -SING OR -XXXXXX END 2 PREPARATION)

END 2 CONNECTOR OR PREPARATION
-0TSP: SMA-P-C-XX-ST-CA1S (SEE SHEET 2)
-01BJ: SMA-J-C-XX-ST-BH1S (SEE SHEET 3)
-02SP: MCX-P-C-XX-ST-CA1S (SEE SHEET 3)
-02SJ: MCX-J-C-XX-ST-CA1S (SEE SHEET 3)
-03SP: MMCX-P-C-XX-ST-CA1S (SEE SHEET 3)
-04BJ: BNC5-J-C-XX-ST-BH1S (SEE SHEET 3)
-05SP: TNC-P-C-XX-ST-CA1S (SEE SHEET 3)
-SING: SINGLE ENDED (ONE END ONLY, SEE NOTE 11)
-XXXXXX: STRIPPED AND TINNED (THIS END ONLY- SEE NOTES 11-15, 18 & SHEET 2, FIG 3)

(SEE FIG 2) "C" FORMAT: X.X mm
(SEE FIG 2) "B" FORMAT: X.X mm
(SEE FIG 2) "A" FORMAT: X.X mm

DO NOT LEAVE ANY SPACE BLANK, EACH MUST CONTAIN A NUMERIC CHARACTER 0 THRU 9.

NOTES:

1. Ⓢ REPRESENTS A CRITICAL DIMENSION.
2. CABLE CUT LENGTH:
= (LENGTH: XXXX) - (SUBTRACTOR FOR END 1) - (SUBTRACTOR FOR END 2).
(SEE TABLE 1 FOR SUBTRACTORS)
3. ASSEMBLY TO BE 100% TESTED FOR OPENS & SHORTS.
4. ASSEMBLY TO BE 100% HI-POT TESTED PER TABLE 1, THE TEST VOLTAGE FOR THE ASSEMBLY SHOULD BE SET TO THE END OPTION WITH THE LOWEST TEST VOLTAGE RATING
5. AFTER FINAL ELECTRICAL TESTS, LABEL EACH CABLE ASSEMBLY WITH 1 LABEL -ET
6. CRITICALS ON CONNECTOR PRINTS TO BE CHECKED IN PROCESS.
7. FINISHED ASSEMBLIES TO BE PACKAGED PER PACKAGING STANDARD CO-HD-WI-3040-M. LOCK WASHERS AND NUTS TO BE SHIPPED UNASSEMBLED. GASKETS TO BE INSTALLED ON CABLE.
8. CABLE STOCKED IN INCHES, 1 INCH = 25.4 MILLIMETERS.
9. CABLE LENGTHS LONGER THAN 1000 MILLIMETERS ARE NOT SUPPORTED BY S.I. TEST DATA.
10. MINIMUM BEND RADIUS FOR RS316 = 12.8 [0.50]
11. FOR SING ENDED OR STRIPPED AND TINNED ASSEMBLIES: MAKE A DOUBLE ENDED ASSEMBLY AT TWICE THE CABLE LENGTH AND TEST BEFORE CUTTING ASSEMBLY IN HALF.
12. DIM "A", "B", AND "C" HAVE A MINIMUM VALUE OF 0.0mm & A MAXIMUM VALUE OF 9.9mm.
13. PRODUCTION OF STRIP AND TIN FOR CENTER DIELECTIC USE: A.
14. PRODUCTION OF STRIP AND TIN FOR SHIELD USE: D=A+B.
15. PRODUCTION OF STRIP AND TIN FOR JACKET USE: E=A+B+C.
16. CONNECTORS TO BE ORIENTED ACCORDING TO CO-HD-WI-3048-M.
17. FOR BULKHEAD APPLICATIONS, THE END USER SHOULD TIGHTEN THE THREADED NUT TO 15 IN-LB MINIMUM.
18. FOR STRIPPED AND TINNED OPTION, ONLY THE CENTER CONDUCTOR IS TINNED.

F:\DWG\MISC\MKTG\RS316-XXXX-XXXXXX-XXXX-MKT.SLDDRW

UNLESS OTHERWISE SPECIFIED, DIMENSIONS ARE IN MILLIMETERS [INCHES]. TOLERANCES ARE: DECIMALS ANGLES .X: ±0.3 [.01] 5° .XX: ±0.13 [.005] .XXX: ±0.051 [.0020]	PROPRIETARY NOTE THIS DOCUMENT CONTAINS INFORMATION CONFIDENTIAL AND PROPRIETARY TO SAMTEC, INC. AND SHALL NOT BE REPRODUCED OR TRANSFERRED TO OTHER DOCUMENTS OR DISCLOSED TO OTHERS OR USED FOR ANY PURPOSE OTHER THAN THAT WHICH IT WAS OBTAINED WITHOUT THE EXPRESSED WRITTEN CONSENT OF SAMTEC, INC.	DESCRIPTION: RG316 (DOUBLE SHIELD) CABLE ASSEMBLY	
		DWG. NO. RS316-XXXXX-XXXXXX-XXXX	
MATERIAL: DO NOT SCALE DRAWING SHEET SCALE: 2:1 SEE END 1 AND END 2 ASSEMBLY PRINTS		BY: EMMA CHEN 3/20/2013 SHEET 1 OF 3	



520 PARK EAST BLVD, NEW ALBANY, IN 47150
 PHONE: 812-944-6733 FAX: 812-948-5047
 e-Mail: info@SAMTEC.com code 55322

TABLE 2: FINAL ASSEMBLY LENGTH TOLERANCE

LENGTH	TOLERANCE
0100-0200 [3.92-7.87]	+3.0 [.12]/-0.0 [.00]
0200-0500 [7.87-19.69]	+5.0 [.20]/-0.0 [.00]
0500-1100 [19.69-43.30]	+10.0 [.40]/-0.0 [.00]
>1100 [43.30]	± 1%

TABLE 1

CABLE STYLE	CABLE STRIPPING DIMENSIONS			CABLE CUT LENGTH SUBTRACTOR	HI-POT DCV
	"A"	"D"	"E"		
-01SPX	2.6 [0.10]	3.6 [0.14]	10.1 [0.40]	5.7 [0.22]	1000
-01BJX	2.9 [0.11]	6.4 [0.25]	12.8 [0.50]	9.0 [0.35]	1000
-02SPX	2.4 [0.09]	3.8 [0.15]	8.5 [0.33]	7.3 [0.29]	1000
-02SJX	2.6 [0.10]	5.0 [0.20]	10.1 [0.40]	6.5 [0.26]	1000
-03SPX	2.0 [0.08]	4.2 [0.17]	9.2 [0.36]	4.2 [0.17]	1000
-04BJX	4.3 [0.17]	8.4 [0.33]	17.6 [0.69]	13.3 [0.52]	1000
-05SPX	5.1 [0.20]	8.6 [0.34]	17.4 [0.69]	9.2 [0.36]	1000
-SING	-	-	-	0.0 [0.00]	1000
-XXXXXX	-	-	-	0.0 [0.00]	1000

FIG 3
RS316-01SPX-102148-XXXX SHOWN

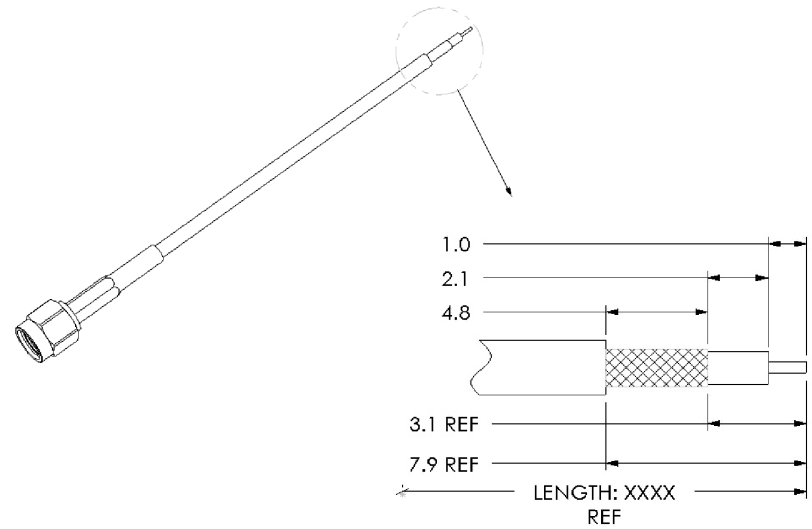

-01SP
(STRAIGHT PLUG)

(USE DRAWING No. SMA-P-C-XX-ST-CA1S FOR ASSEMBLY INSTRUCTIONS)

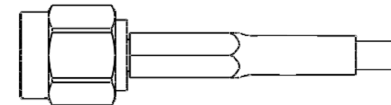

PLATING

- 1: 30µ" MIN. GOLD CENTER CONTACT
- 3µ" MIN. GOLD OUTER CONTACT
- 3µ" MIN. GOLD REMAINING METAL PARTS (END CONNECTOR P/N: SMA-P-C-HF-ST-CA1S)

NOTE: ALL CRITICAL DIMENSIONS ON SMA-P-C-XX-ST-CA1S THAT APPLY MUST BE VERIFIED.

PROPRIETARY NOTE

THIS DOCUMENT CONTAINS INFORMATION CONFIDENTIAL AND PROPRIETARY TO SAMTEC, INC. AND SHALL NOT BE REPRODUCED OR TRANSFERRED TO OTHER DOCUMENTS OR DISCLOSED TO OTHERS OR USED FOR ANY PURPOSE OTHER THAN THAT WHICH IT WAS OBTAINED WITHOUT THE EXPRESSED WRITTEN CONSENT OF SAMTEC, INC.

DO NOT SCALE DRAWING

SHEET SCALE: 1:1



520 PARK EAST BLVD, NEW ALBANY, IN 47150
PHONE: 812-944-6733 FAX: 812-948-5047
e-Mail info@SAMTEC.com code 55322

DESCRIPTION:
RG316 (DOUBLE SHIELD) CABLE ASSEMBLY

DWG. NO.
RS316-XXXXX-XXXXXX-XXXX

BY: EMMA CHEN 3/20/2013 SHEET 2 OF 3

REVISION D

-01BJ
(STRAIGHT BULKHEAD JACK)

(USE DRAWING No. SMA-J-C-XX-ST-BH1S FOR ASSEMBLY INSTRUCTIONS)

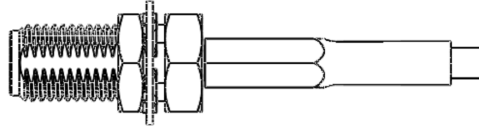

PLATING
 1: 30µ" MIN. GOLD CENTER CONTACT
 3µ" MIN. GOLD OUTER CONTACT
 3µ" MIN. GOLD REMAINING METAL PARTS
 (END CONNECTOR P/N: SMA-J-C-HF-ST-BH1S)

NOTE: ALL CRITICAL DIMENSIONS ON SMA-J-C-XX-ST-BH1S THAT APPLY MUST BE VERIFIED.

-02SP
(STRAGTHT PLUG)

(USE DRAWING No. MCX-P-C-XX-ST-CA1S FOR ASSEMBLY INSTRUCTIONS)

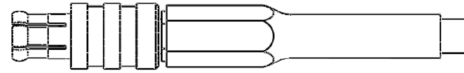

PLATING
 1: 30µ" MIN. GOLD CENTER CONTACT
 3µ" MIN. GOLD OUTER CONTACT
 3µ" MIN. GOLD REMAINING METAL PARTS
 (END CONNECTOR P/N: MCX-P-C-HF-ST-CA1S)

2: 30µ" MIN. GOLD CENTER CONTACT
 3µ" MIN. GOLD OUTER CONTACT
 100µ" MIN. NICKEL REMAINING METAL PARTS
 (END CONNECTOR P/N: MCX-P-C-HN-ST-CA1S)

NOTE: ALL CRITICAL DIMENSIONS ON MCX-P-C-XX-ST-CA1S THAT APPLY MUST BE VERIFIED.

-02SJ
(STRAIGHT JACK)

(USE DRAWING No. MCX-J-C-XX-ST-CA1S FOR ASSEMBLY INSTRUCTIONS)

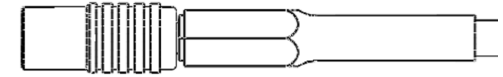

PLATING
 1: 30µ" MIN. GOLD CENTER CONTACT
 3µ" MIN. GOLD OUTER CONTACT
 3µ" MIN. GOLD REMAINING METAL PARTS
 (END CONNECTOR P/N: MCX-J-C-HF-ST-CA1S)

NOTE: ALL CRITICAL DIMENSIONS ON MCX-J-C-XX-ST-CA1S THAT APPLY MUST BE VERIFIED.

-03SP
(STRAGTHT PLUG)

(USE DRAWING No. MMCX-P-C-XX-ST-CA1S FOR ASSEMBLY INSTRUCTIONS)

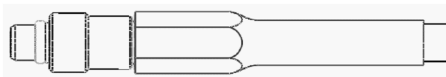

PLATING
 1: 30µ" MIN. GOLD CENTER CONTACT
 3µ" MIN. GOLD OUTER CONTACT
 3µ" MIN. GOLD REMAINING METAL PARTS
 (END CONNECTOR P/N: MMCX-P-C-HF-ST-CA1S)

2: 30µ" MIN. GOLD CENTER CONTACT
 3µ" MIN. GOLD OUTER CONTACT
 100µ" MIN. NICKEL REMAINING METAL PARTS
 (END CONNECTOR P/N: MMCX-P-C-HN-ST-CA1S)

NOTE: ALL CRITICAL DIMENSIONS ON MMCX-P-C-XX-ST-CA1S THAT APPLY MUST BE VERIFIED.

-04BJ
(STRAIGHT BULKHEAD JACK)

(USE DRAWING No. BNC5-J-C-XX-ST-BH1S FOR ASSEMBLY INSTRUCTIONS)

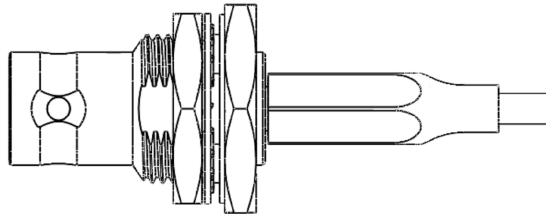

PLATING
 2: 30µ" MIN. GOLD CENTER CONTACT
 3µ" MIN. GOLD OUTER CONTACT
 100µ" MIN. NICKEL REMAINING METAL PARTS
 (END CONNECTOR P/N: BNC5-J-C-HN-ST-BH1S)

3: 10µ" MIN. GOLD CENTER CONTACT
 100µ" MIN. NICKEL OUTER CONTACT
 100µ" MIN. NICKEL REMAINING METAL PARTS
 (END CONNECTOR P/N: BNC5-J-C-GN-ST-BH1S)

NOTE: ALL CRITICAL DIMENSIONS ON BNC5-J-C-XX-ST-BH1S THAT APPLY MUST BE VERIFIED.

-05SP
(STRAGTHT PLUG)

(USE DRAWING No. TNC-P-C-XX-ST-CA1S FOR ASSEMBLY INSTRUCTIONS)

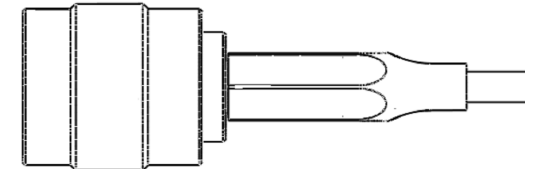

PLATING
 3: 10µ" MIN. GOLD CENTER CONTACT
 100µ" MIN. NICKEL OUTER CONTACT
 100µ" MIN. NICKEL REMAINING METAL PARTS
 (END CONNECTOR P/N: TNC-P-C-GN-ST-CA1S)

NOTE: ALL CRITICAL DIMENSIONS ON TNC-P-C-XX-ST-CA1S THAT APPLY MUST BE VERIFIED.

PROPRIETARY NOTE

THIS DOCUMENT CONTAINS INFORMATION CONFIDENTIAL AND PROPRIETARY TO SAMTEC, INC. AND SHALL NOT BE REPRODUCED OR TRANSFERRED TO OTHER DOCUMENTS OR DISCLOSED TO OTHERS OR USED FOR ANY PURPOSE OTHER THAN THAT WHICH IT WAS OBTAINED WITHOUT THE EXPRESSED WRITTEN CONSENT OF SAMTEC, INC.

DO NOT SCALE DRAWING

SHEET SCALE: 1:1



520 PARK EAST BLVD, NEW ALBANY, IN 47150
 PHONE: 812-944-6733 FAX: 812-948-5047
 e-Mail info@SAMTEC.com code 55322

DESCRIPTION:
 RG316 (DOUBLE SHIELD) CABLE ASSEMBLY

DWG. NO.
 RS316-XXXXX-XXXXXX-XXXX

BY: EMMA CHEN 3/20/2013 SHEET 3 OF 3