

YTT-1XX-XX-X-X-XXX-XX

No OF POSITIONS
 -02 THRU -50 (PER ROW)

LEAD STYLE
 -01: .126 [3.20] (USE T-1S13-07-X-2)
 -04: .075 [1.91] (USE T-1S13-04-X-2)

OPTION
 ** -MW: METAL WASHER (Q BODY SPECS ONLY) (SEE FIG. 2, SHT. 2) (.300 [7.62] MAX TAIL)

OPTIONS
 -XXX: INDICATES POSITION POLARIZED

ROW OPTION
 -Q: QUAD ROW (USE TMMH-50-Q)
 -5: FIVE ROW (USE TMMH-50-5)
 -6: SIX ROW (USE TMMH-50-6)

PLATING
 -L: LIGHT SELECTIVE (USE T-1S13-XX-L-2)
 -F: FLASH SELECTIVE (USE T-1S13-XX-F-2)
 -S: SELECTIVE GOLD (USE T-1S13-XX-S-2)
 -G: GOLD (USE T-1S13-XX-G-2)
 -T: TIN (USE T-1S13-XX-T-2)
 -H: HEAVY GOLD (USE T-1S13-XX-H-2)

**** - MW OPTION, DO NOT DESIGN IN. SAMTEC WILL ONLY SUPPORT EXISTING BUSINESS 2/06/02.**

LEAD STYLE	TABLE 1		
	"A"	"B"	TERMINAL "C"
-01	.126 [3.20]	.302 [7.67]	T-1S13-07-X-2 .097 [2.46]
-04	.075 [1.91]	.255 [6.48]	T-1S13-04-X-2 .101 [2.57]

TABLE 2	
ROW SPEC.	"D"
-Q	3
-5	4
-6	5

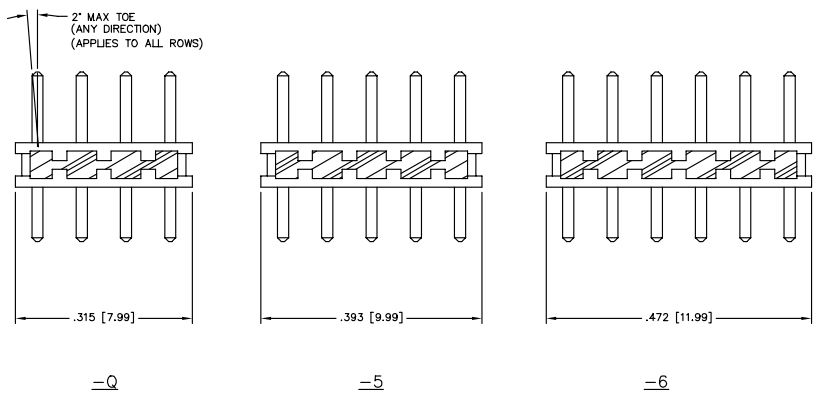
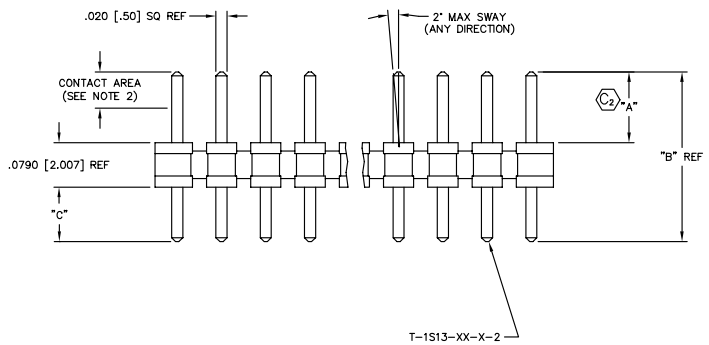

Do not scale from this print

- NOTES:
- PARTS MAY BE CUT TO POSITION.
 - GOLD PLATING TO BE ON POST, TIN PLATING ON TAIL ON SELECTIVE PLATED PART.
 - Ⓢ REPRESENTS A CRITICAL DIMENSION.
 - MINIMUM PUSHOUT FORCE: 1.0 LB.
 - BULK PACKAGED
 - MAX CUT FLASH: .005 [.13]
 - .005 MAX VARIATION PIN/PIN
 - MUST USE CARBIDE BLADES.
 - ORIENTATE PINS TO REDUCE THE NUMBER OF BANDOLIER MARKS IN THE POST AREA. (SEE TABLE 3)

PROPRIETARY NOTE
 THIS DOCUMENT CONTAINS INFORMATION CONFIDENTIAL AND PROPRIETARY TO SAMTEC INC. AND SHALL NOT BE REPRODUCED OR TRANSFERRED TO OTHER DOCUMENTS OR DISCLOSED TO OTHERS OR USED FOR ANY PURPOSE OTHER THAN THAT FOR WHICH IT WAS OBTAINED WITHOUT THE EXPRESSED WRITTEN CONSENT OF SAMTEC INC.

PLOT SCALE: .175 / DIMSCALE: .100

samtec
 520 PARK EAST BLVD. NEW ALBANY, INDIANA 47150
 PHONE (812) 944-6733 P.O. BOX 1147
 CODE 55322

MISC/MKTG
 YTT-MKT